

visual engineering  
**LIGHTWARE**

**User's Manual**



**MMX8x8-HDMI-4K-A**  
**MMX8x8-HDMI-4K-A-USB20**

**Multiport Matrix Switcher**

## Important Safety Instructions

### Class I apparatus construction.

This equipment must be used with a mains power system with a protective earth connection. The third (earth) pin is a safety feature, do not bypass or disable it. The equipment should be operated only from the power source indicated on the product.

To disconnect the equipment safely from power, remove the power cord from the rear of the equipment or from the power source. The MAINS plug is used as the disconnect device, the disconnect device shall remain readily operable.

There are no user-serviceable parts inside of the unit. Removal of the cover will expose dangerous voltages. To avoid personal injury, do not remove the cover. Do not operate the unit without the cover installed.

The appliance must be safely connected to multimedia systems. Follow instructions described in this manual.

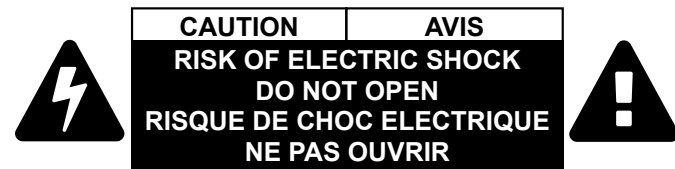

### Ventilation

For the correct ventilation and to avoid overheating ensure enough free space around the appliance. Do not cover the appliance, let the ventilation holes free and never block or bypass the ventilators (if any).

### WARNING

To prevent injury, the apparatus is recommended to be securely attached to the floor/wall or mounted in accordance with the installation instructions. The apparatus shall not be exposed to dripping or splashing, and no objects filled with liquids, such as vases, shall be placed on the apparatus. No naked flame sources, such as lit candles, should be placed on the apparatus.

## Waste Electrical & Electronic Equipment WEEE

This marking shown on the product or its literature indicates that it should not be disposed with other household wastes at the end of its working life. To prevent possible harm to the environment or human health from uncontrolled waste disposal, please separate this from other types of wastes and recycle it responsibly to promote the sustainable reuse of material resources. Household users should contact either the retailer where they purchased this product or their local government office for details of where and how they can take this item for environmentally safe recycling. Business users should contact their supplier and check the terms and conditions of the purchase contract. This product should not be mixed with other commercial wastes for disposal.

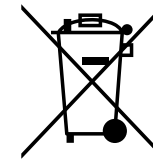

## Common Safety Symbols

Symbol	Description
	Alternating current
	Protective conductor terminal
	Caution, possibility of electric shock
	Caution

## Symbol Legend

The following symbols and markings are used in the document:

**WARNING!** Safety-related information that is highly recommended to read and keep in every case!

**ATTENTION!** Useful information to perform a successful procedure; it is recommended to read.

**DIFFERENCE:** Feature or function that is available with a specific firmware/hardware version or product variant.

**INFO:** A notice, which may contain additional information. Procedure can be successful without reading it.

**DEFINITION:** The short description of a feature or a function.

**TIPS AND TRICKS:** Ideas that you may have not known yet but can be useful.

## Navigation Buttons

 Go back to the previous page. If you clicked on a link previously, you can go back to the source page by pressing the button.

 Navigate to the Table of Contents.

 Step back one page.

 Step forward to the next page.

## Document Information

All presented functions refer to the indicated products. The descriptions have been made while testing these functions in accordance with the indicated Hardware/Firmware/Software environment:

Item	Version
Lightware Device Controller (LDC) software	2.7.5b2
Lightware Device Updater2 Software	2.23.0b1
Firmware package	1.4.4b1
Hardware	1.2

Document revision: **v1.4**

Release date: **14-12-2023**

Editor: Tamas Forgacs

## About Printing

Lightware Visual Engineering supports green technologies and eco-friendly mentality. Thus, this document is primarily made for digital use. If you need to print out a few pages for any reason, follow the recommended printing settings:

- Page size: A4
- Output size: Fit to page or Match page size
- Orientation: Landscape

**TIPS AND TRICKS:** Thanks to the size of the original page, the border around the content (grey on the second picture below) makes it possible to organize the pages better. After punching holes in the printed pages, they can easily be placed into a ring folder.

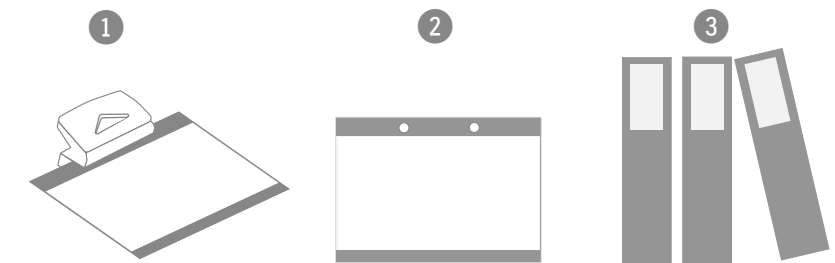

## Hashtag (#) Keywords in the Document

This user's manual contains keywords with hashtags (#) to help you find the relevant information as quick as possible.

The format of the keywords is the following:

#<keyword>

The usage of the keywords: use the **Search** function (Ctrl+F / Cmd+F) of your PDF reader application, type the #(hashtag) character and the wished keyword.

The **#new** special keyword indicates a new feature/function that has just appeared in the latest firmware or software version.

### Example

#dhcp

This keyword is placed at the DHCP setting command in the LW3 Programmer's reference section.

# Table of Contents

<b>1. INTRODUCTION</b> .....	<b>8</b>	<b>5. DEVICE CONCEPT</b> .....	<b>33</b>	<b>6.10. EDID MENU</b> .....	<b>57</b>
<b>1.1. DESCRIPTION</b> .....	<b>9</b>	<b>5.1. HDMI AND TPS MATRIX CONCEPT</b> .....	<b>34</b>	6.10.1. Sources and Destinations .....	57
1.1.1. Compatible Devices .....	9	<b>5.2. VIDEO INTERFACE</b> .....	<b>34</b>	6.10.2. EDID Operations .....	57
<b>1.2. BOX CONTENTS</b> .....	<b>10</b>	5.2.1. Port Diagram of the MMX8x8-HDMI-4K-A and -USB20 Models ...	34	6.10.3. EDID Summary Window .....	58
<b>1.3. MODEL COMPARISON</b> .....	<b>10</b>	5.2.2. The Autoselect Feature .....	35	6.10.4. Editing an EDID .....	58
<b>1.4. FEATURES</b> .....	<b>11</b>	<b>5.3. AUDIO INTERFACE</b> .....	<b>35</b>	6.10.5. Creating an EDID .....	59
1.4.1. List of Features.....	11	5.3.1. MMX8x8-HDMI-4K-A and MMX8x8-HDMI-4K-A-USB20.....	35	<b>6.11. CONTROL MENU</b> .....	<b>60</b>
1.4.2. Feature Availability .....	12	5.3.2. General Audio Settings from Inputs to Outputs .....	36	6.11.1. RS-232 Tab.....	60
<b>1.5. TYPICAL APPLICATION</b> .....	<b>13</b>	<b>5.4. ETHERNET INTERFACE</b> .....	<b>38</b>	6.11.2. GPIO Tab.....	61
<b>2. PRODUCT OVERVIEW</b> .....	<b>15</b>	5.4.1. TCP Recognizer .....	38	6.11.3. Ethernet.....	61
<b>2.1. FRONT VIEW</b> .....	<b>16</b>	<b>5.5. BULK DEVICE MANAGEMENT</b> .....	<b>38</b>	6.11.4. Infra Tab.....	63
<b>2.2. REAR VIEW</b> .....	<b>17</b>	5.5.1. Network Settings.....	38	6.11.5. USB Switch Tab .....	64
<b>3. FRONT PANEL CONTROL</b> .....	<b>18</b>	<b>5.6. INFRA INTERFACE</b> .....	<b>39</b>	6.11.6. Macros .....	64
<b>3.1. FRONT PANEL LCD MENU OPERATIONS</b> .....	<b>19</b>	<b>5.7. SERIAL INTERFACE</b> .....	<b>40</b>	6.11.7. Variables .....	65
3.1.1. System Settings Menu .....	19	5.7.1. Technical Background.....	40	<b>6.12. EVENT MANAGER</b> .....	<b>67</b>
3.1.2. Ports Menu .....	20	5.7.2. Serial Port Operation Modes .....	41	6.12.1. The Event Editor .....	67
3.1.3. EDID Menu .....	21	5.7.3. RS-232 Recognizer .....	42	6.12.2. Create or Modify an Event .....	68
3.1.4. Health Menu .....	22	<b>5.8. BATCH COMMANDS</b> .....	<b>42</b>	6.12.3. Special Tools and Accessories .....	69
3.1.5. Crosspoint Menu .....	22	<b>5.9. GPIO INTERFACE</b> .....	<b>43</b>	6.12.4. Clear One or More Event(s).....	70
<b>3.2. FRONT PANEL BUTTON OPERATIONS</b> .....	<b>23</b>	<b>5.10. CONSUMER ELECTRONICS CONTROL (CEC) INTERFACE</b> .....	<b>43</b>	6.12.5. Export and Import Events .....	70
3.2.1. Control Lock.....	23	<b>5.11. THE EVENT MANAGER FEATURE</b> .....	<b>44</b>	6.12.6. Event Creating - Example .....	70
3.2.2. Take / Autotake Modes.....	23	<b>5.12. BASIC IT SECURITY</b> .....	<b>44</b>	<b>6.13. SETTINGS MENU</b> .....	<b>71</b>
3.2.3. View Crosspoint State.....	23	<b>5.13. USB INTERFACE</b> .....	<b>45</b>	6.13.1. Status.....	71
3.2.4. Switching Operations.....	24	5.13.1. USB Control .....	45	6.13.2. Network.....	71
3.2.5. Output Lock .....	24	5.13.2. USB 2.0 Interface .....	45	6.13.3. Backup .....	72
3.2.6. Control Lock.....	25	<b>6. SOFTWARE CONTROL – LIGHTWARE DEVICE CONTROLLER</b> .....	<b>47</b>	6.13.4. System .....	72
3.2.7. Save or Load a Preset .....	25	<b>6.1. INSTALL AND UPGRADE</b> .....	<b>48</b>	<b>6.14. CONFIGURATION CLONING (BACKUP TAB)</b> .....	<b>73</b>
<b>4. INSTALLATION</b> .....	<b>27</b>	<b>6.2. RUNNING THE LDC</b> .....	<b>48</b>	6.14.1. Cloning Steps in a Nutshell.....	73
<b>4.1. MOUNTING OPTIONS -STANDARD RACK INSTALLATION</b> .....	<b>28</b>	<b>6.3. DEVICE DISCOVERY WINDOW</b> .....	<b>49</b>	6.14.2. Save the Settings of the Device (Backup).....	73
<b>4.2. ELECTRICAL CONNECTIONS</b> .....	<b>29</b>	<b>6.4. BULK DEVICE MANAGEMENT</b> .....	<b>50</b>	6.14.3. Upload the Settings to a Device (Restore).....	74
4.2.1. HDMI Input and Output Ports .....	29	6.4.1. Network Settings.....	50	6.14.4. Create and Restore Backups from the Device Memory.....	74
4.2.2. Analog Stereo Audio .....	29	<b>6.5. CROSSPOINT MENU</b> .....	<b>51</b>	<b>6.15. THE BUILT-IN MINIWEB</b> .....	<b>75</b>
4.2.3. RS-232 Connector .....	29	6.5.1. Crosspoint Operations .....	51	6.15.1. Opening the Miniweb .....	75
4.2.4. Infra/ Serial TTL Connector .....	29	<b>6.6. PORT PROPERTIES WINDOWS</b> .....	<b>52</b>	6.15.2. The Default Status Page .....	76
4.2.5. Control Ethernet Port .....	30	6.6.1. HDMI Input Port Properties .....	52	6.15.3. Miniweb Customization .....	76
4.2.6. IR Connector .....	30	6.6.2. HDMI Output Port Properties.....	53	<b>6.16. ADVANCED VIEW</b> .....	<b>77</b>
4.2.7. GPIO - General Purpose Input/Output Ports.....	31	<b>6.7. CEC TOOL</b> .....	<b>54</b>	<b>7. LW2 PROGRAMMERS' REFERENCE</b> .....	<b>78</b>
4.2.8. USB Connector .....	31	<b>6.8. DIAGNOSTIC TOOLS</b> .....	<b>55</b>	<b>7.1. PROTOCOL DESCRIPTION</b> .....	<b>79</b>
<b>4.3. CONNECTING STEPS</b> .....	<b>32</b>	6.8.1. Frame Detector.....	55	<b>7.2. INSTRUCTIONS FOR THE TERMINAL APPLICATION USAGE</b> .....	<b>79</b>
<b>4.4. POWERING ON</b> .....	<b>32</b>	6.8.2. Test Pattern Generator - No Sync Screen .....	55	<b>7.3. GENERAL LW2 COMMANDS</b> .....	<b>80</b>
		<b>6.9. PRESETS TAB</b> .....	<b>56</b>	7.3.1. Querying the Supported Commands.....	80
				7.3.2. Viewing Product Type .....	80

7.3.3. Viewing Serial Number .....	80	8.3.9. Notifications about the Changes of the Properties .....	90	8.7.18. Setting the Signal Type (Output Ports) .....	98
7.3.4. Querying Device Label.....	80	8.3.10. Legend for the Control Commands.....	90	8.7.19. Test Pattern .....	98
7.3.5. Querying Control Protocol .....	80	<b>8.4. SYSTEM COMMANDS.....</b>	<b>91</b>	<b>8.8. EDID MANAGEMENT .....</b>	<b>99</b>
7.3.6. Viewing Firmware Version of the Firmware Package .....	80	8.4.1. Querying the Product Name .....	91	8.8.1. Querying the Emulated EDIDs.....	99
7.3.7. Connection Test.....	81	8.4.2. Querying the Device Label .....	91	8.8.2. Setting the Emulated EDID.....	99
7.3.8. Compile Time.....	81	8.4.3. Setting the Device Label .....	91	8.8.3. Copying an EDID into Another Slot.....	99
7.3.9. Viewing Installed Board(s).....	81	8.4.4. Querying the Serial Number.....	91	<b>8.9. AUX ANALOG AUDIO I/O PORT SETTINGS.....</b>	<b>100</b>
7.3.10. Viewing Firmware for all Controllers' .....	81	8.4.5. Querying the Package Version .....	91	8.9.1. Setting the Audio Mode .....	100
7.3.11. Restarting the Matrix Router .....	81	8.4.6. Querying the CPU Firmware Version.....	91	8.9.2. Muting/Unmuting the AUX Analog Audio Input.....	100
7.3.12. Querying Health Status .....	81	8.4.7. Identifying the Device.....	91	8.9.3. Setting the AUX Analog Audio Input Volume.....	100
7.3.13. Restoring Factory Default Settings .....	82	8.4.8. Setting the Rotary Direction of the Jog Dial Knob.....	92	8.9.4. Setting the AUX Analog Audio Input Balance .....	100
<b>7.4. PORT AND CROSSPOINT SETTINGS .....</b>	<b>82</b>	8.4.9. Running a Macro .....	92	8.9.5. Setting the AUX Analog Audio Input Gain.....	100
7.4.1. Switching One Input to One Output.....	82	8.4.10. Control Lock .....	92	8.9.6. Muting/Unmuting the AUX Analog Audio Output.....	101
7.4.2. Switching One Input to All Output .....	82	8.4.11. Resetting the Matrix.....	92	8.9.7. Setting the AUX Analog Audio Output Volume.....	101
7.4.3. Muting Specified Output .....	82	8.4.12. Restoring the Factory Default Settings.....	92	8.9.8. Setting the AUX Analog Audio Output Balance .....	101
7.4.4. Unmuting Specified Output.....	82	<b>8.5. CLEARTEXT LOGIN PROTECTION .....</b>	<b>93</b>	<b>8.10. SERIAL PORT CONFIGURATION .....</b>	<b>101</b>
7.4.5. Locking the Output .....	83	8.5.1. Setting the Login Password.....	93	8.10.1. Setting the Protocol .....	101
7.4.6. Unlocking the Output.....	83	8.5.2. Logging into the Device.....	93	8.10.2. Setting the BAUD Rate .....	101
7.4.7. Viewing Connection State on the Output.....	83	8.5.3. Logging out of the Device .....	93	8.10.3. Setting the Operation Mode.....	102
7.4.8. Viewing Crosspoint Size .....	83	8.5.4. Enabling/Disabling the Cleartext Login Function.....	93	8.10.4. Enabling/Disabling the Command Injection Mode .....	102
7.4.9. Batch Switching Outputs .....	84	<b>8.6. SWITCHING AND CROSSPOINT SETTINGS.....</b>	<b>94</b>	8.10.5. Querying the RS-232 Command Injection Port Number .....	102
<b>7.5. NETWORK CONFIGURATION .....</b>	<b>84</b>	8.6.1. Querying the Video Crosspoint State .....	94	<b>8.11. SERIAL PORT MESSAGING .....</b>	<b>102</b>
7.5.1. Querying the Current IP Status .....	84	8.6.2. Switching an Input to an Output .....	94	8.11.1. Sending a Message (ASCII-format) via RS-232.....	102
7.5.2. Setting the IP Address .....	84	8.6.3. Switching an Input to All Outputs.....	94	8.11.2. Sending a Text (ASCII-format) via RS-232.....	102
7.5.3. Setting the Subnet Mask.....	85	<b>8.7. VIDEO PORT SETTINGS.....</b>	<b>94</b>	8.11.3. Sending a Binary Message (HEX-format) via RS-232 .....	103
7.5.4. Setting the Gateway Address .....	85	8.7.1. Muting an Input Port .....	94	8.11.4. Using Hexadecimal Codes.....	103
7.5.5. Applying Network Settings .....	85	8.7.2. Unmuting an Input Port.....	94	<b>8.12. RS-232 MESSAGE RECOGNIZER .....</b>	<b>103</b>
<b>7.6. GPIO SETTINGS.....</b>	<b>85</b>	8.7.3. Muting an Output Port.....	94	8.12.1. Enabling/Disabling the Recognizer .....	103
7.6.1. Setting the GPIO State .....	85	8.7.4. Unmuting an Output Port.....	94	8.12.2. Setting the Delimiter Hex .....	104
<b>7.7. LW2 COMMANDS – QUICK SUMMARY .....</b>	<b>86</b>	8.7.5. Locking an Input Port.....	95	8.12.3. Setting the Timeout.....	104
<b>8. LW3 PROGRAMMERS' REFERENCE .....</b>	<b>87</b>	8.7.6. Unlocking an Input Port .....	95	8.12.4. Querying the Last Recognized Message (String).....	104
<b>8.1. OVERVIEW.....</b>	<b>88</b>	8.7.7. Locking an Output Port .....	95	8.12.5. Querying the Last Recognized Message(Hex) .....	104
<b>8.2. INSTRUCTIONS FOR THE TERMINAL APPLICATION USAGE.....</b>	<b>88</b>	8.7.8. Unlocking an Output Port.....	95	8.12.6. Clearing the Last Recognized Stored Message .....	104
<b>8.3. PROTOCOL RULES.....</b>	<b>88</b>	8.7.9. Setting the HDCP (Input Port) .....	95	8.12.7. Querying the Last Recognized Active Message (String) .....	105
8.3.1. LW3 Tree Structure and Command Structure (examples).....	88	8.7.10. Setting the HDCP (Output Port).....	95	8.12.8. Querying the Last Recognized Active Message (Hex).....	105
8.3.2. General Rules.....	88	8.7.11. Querying the Connected Input Port Number .....	95	8.12.9. Setting the Active Timeout .....	105
8.3.3. Command Types .....	89	8.7.12. Querying the Status of the Source Port .....	96	8.12.10. Running an Immediate Event Action.....	105
8.3.4. Prefix Summary .....	89	8.7.13. Querying the Status of the Destination Port.....	97	<b>8.13. IR PORT CONFIGURATION .....</b>	<b>106</b>
8.3.5. Error Messages .....	89	8.7.14. Querying the Video Autoselect Settings .....	97	8.13.1. Enabling/Disabling the IR Port .....	106
8.3.6. Escaping .....	89	8.7.15. Changing the Autoselect Mode.....	97	8.13.2. Querying the IR Command Injection Port Number.....	106
8.3.7. Signature.....	90	8.7.16. Querying the Input Port Priority .....	97	<b>8.14. IR PORT MESSAGING .....</b>	<b>106</b>
8.3.8. Subscription.....	90	8.7.17. Changing the Input Port Priority .....	98	8.14.1. Sending Pronto Hex Codes in Little-endian Format.....	106
				8.14.2. Sending Pronto Hex Codes in Big-endian Format.....	107

<b>8.15. ETHERNET CONFIGURATION</b> .....	<b>107</b>	<b>8.20. EVENT MANAGER BASICS</b> .....	<b>115</b>	8.26.3. Querying the Embedded Audio.....	125
8.15.1. Querying the Current IP Address.....	107	8.20.1. How to arrange an Event?.....	115	8.26.4. Hotplug Detect .....	125
8.15.2. Querying the Current DHCP Status .....	107	8.20.2. Setting a Condition by Specifying a Direct Path.....	115	<b>8.27. LW3 QUICK SUMMARY</b> .....	<b>126</b>
8.15.3. Setting a Dynamic IP Address .....	107	8.20.3. Setting a Condition by Linking Another Condition .....	115	<b>9. FIRMWARE UPDATE</b> .....	<b>132</b>
8.15.4. Setting a Static IP Address .....	108	8.20.4. Setting a Condition by Linking Conditions.....	115	<b>9.1. INTRODUCTION</b> .....	<b>133</b>
8.15.5. Changing the Subnet Mask (Static) .....	108	8.20.5. Setting an Action by Specifying a Direct Path .....	116	<b>9.2. PREPARATION</b> .....	<b>133</b>
8.15.6. Changing the Gateway Address (Static).....	108	8.20.6. Setting an Action by Linking Another Action .....	116	9.2.1. About the Firmware Package (LFP2 File) .....	133
8.15.7. Applying Network Settings .....	108	8.20.7. Setting an Action by Linking a Macro .....	116	9.2.2. LDU2 Installation .....	133
<b>8.16. ETHERNET MESSAGE SENDING</b> .....	<b>108</b>	<b>8.21. EVENT MANAGER TOOL KIT</b> .....	<b>117</b>	9.2.3. LDU2 Installation .....	133
8.16.1. Sending a TCP Message (ASCII-format).....	108	8.21.1. Setting the Delay .....	117	<b>9.3. RUNNING THE SOFTWARE</b> .....	<b>134</b>
8.16.2. Sending a TCP Text (ASCII-format).....	108	8.21.2. Setting the Name of the Event.....	117	<b>9.4. THE UPDATING STEPS</b> .....	<b>135</b>
8.16.3. Sending a TCP Binary Message (HEX-format) .....	109	8.21.3. Enabling/Disabling an Event.....	118	<b>9.5. COMMAND LINE INTERFACE (CLI)</b> .....	<b>137</b>
8.16.4. Sending UDP Message (ASCII-format) .....	109	8.21.4. Triggering a Condition.....	118	9.5.1. How to Run .....	137
8.16.5. Sending a UDP Text (ASCII-format) .....	109	8.21.5. Querying the Condition Counter .....	118	9.5.2. How to Use.....	138
8.16.6. Sending a UDP Binary Message (HEX-format).....	109	8.21.6. Querying the Condition Trigger Counter .....	118	<b>9.6. CLI COMMANDS</b> .....	<b>138</b>
<b>8.17. TCP MESSAGE RECOGNIZER</b> .....	<b>110</b>	8.21.7. Testing an Action .....	118	9.6.1. Help .....	138
8.17.1. Setting the IP Address of the TCP Server .....	110	<b>8.22. VARIABLE-MANAGEMENT</b> .....	<b>119</b>	9.6.2. LDU2 Version .....	138
8.17.2. Setting the TCP/IP Port Number of the TCP Server.....	110	8.22.1. Value Assignment .....	119	9.6.3. Check For New LDU2 Version.....	138
8.17.3. Connecting to a TCP Server.....	110	8.22.2. Addition and Subtraction (Add Method).....	119	9.6.4. Device Info .....	139
8.17.4. Disconnecting from a TCP Server .....	110	8.22.3. Addition and Subtraction (Cycle Method) .....	120	9.6.5. Update.....	139
8.17.5. Setting the Delimiter Hex .....	110	8.22.4. Value Change with Intervals (Case) .....	120	9.6.6. Restore .....	140
8.17.6. Setting the Timeout.....	111	8.22.5. Scan and Store .....	121	9.6.7. Package Options .....	140
8.17.7. Querying the Last Recognized Message (String).....	111	8.22.6. Reformatting a Value .....	121	9.6.8. Complex Examples.....	141
8.17.8. Querying the Last Recognized Message (Hex).....	111	<b>8.23. ETHERNET TOOL KIT</b> .....	<b>122</b>	9.6.9. Exit Codes .....	142
8.17.9. Clearing the Last Recognized Stored Message .....	111	8.23.1. Device Filter Based on MAC Address .....	122	<b>9.7. IF THE UPDATE IS NOT SUCCESSFUL</b> .....	<b>142</b>
8.17.10. Querying the Last Recognized Active Message (String) .....	111	8.23.2. Blocking the LW2 Control Port .....	122	<b>10. TROUBLESHOOTING</b> .....	<b>143</b>
8.17.11. Querying the Last Recognized Active Message (Hex).....	112	8.23.3. Blocking the HTTP Port .....	122	<b>10.1. USE CASE STUDIES</b> .....	<b>144</b>
8.17.12. Setting the Active Timeout .....	112	8.23.4. Blocking the HTTP Post Receiving.....	122	<b>10.2. HOW TO SPEED UP THE TROUBLESHOOTING PROCESS?</b> .....	<b>145</b>
8.17.13. Running an Immediate Event Action.....	112	8.23.5. Powering on a Computer over Ethernet (Wake-on-LAN) .....	123	<b>11. TECHNOLOGIES</b> .....	<b>146</b>
<b>8.18. HTTP MESSAGING</b> .....	<b>112</b>	8.23.6. Setting the Host Name.....	123	<b>11.1. EDID MANAGEMENT</b> .....	<b>147</b>
8.18.1. Setting the Target IP Address.....	112	<b>8.24. GPIO PORT SETTINGS</b> .....	<b>123</b>	11.1.1. Understanding the EDID.....	147
8.18.2. Setting the TCP Port.....	112	8.24.1. Setting the Direction of a GPIO Pin .....	123	11.1.2. Advanced EDID Management.....	147
8.18.3. Setting the Target Path .....	112	8.24.2. Setting the Output Level of a GPIO Pin .....	123	<b>11.2. HDCP MANAGEMENT</b> .....	<b>148</b>
8.18.4. Setting the Message Header.....	113	8.24.3. Toggling the Level of a GPIO Pin.....	123	11.2.1. Protected and Unprotected Content .....	148
8.18.5. Sending a Post Message .....	113	<b>8.25. USB PORT SETTINGS</b> .....	<b>124</b>	11.2.2. Disable Unnecessary Encryption.....	148
8.18.6. Sending a Put Message .....	113	8.25.1. USB Host Select .....	124	<b>11.3. PIXEL ACCURATE RECLOCKING</b> .....	<b>149</b>
<b>8.19. CEC COMMAND SENDING</b> .....	<b>113</b>	8.25.2. Power Switch Delay.....	124	<b>12. APPENDIX</b> .....	<b>150</b>
8.19.1. Press&Release Commands .....	113	8.25.3. Host 5V Sense .....	124	<b>12.1. SPECIFICATIONS</b> .....	<b>151</b>
8.19.2. Further Commands .....	114	8.25.4. Device 5V Enable.....	124	<b>12.2. MECHANICAL DRAWINGS</b> .....	<b>152</b>
8.19.3. Sending an OSD String.....	114	8.25.5. Querying the 5V Overcurrent Status of the Device.....	124	<b>12.3. FACTORY DEFAULT SETTINGS</b> .....	<b>153</b>
8.19.4. Sending CEC Commands in Hex Format .....	114	<b>8.26. SYSTEM MONITORING COMMANDS</b> .....	<b>125</b>		
8.19.5. Querying the Last Received CEC Message.....	114	8.26.1. Querying Video Signal Presence .....	125		
		8.26.2. Querying the Connected Device (or Cable).....	125		

<b>12.4. CONTENT OF THE BACKUP FILE .....</b>	<b>154</b>
<b>12.5. FLOWCHART OF AUTOSELECT MODES .....</b>	<b>155</b>
<b>12.6. PORT NUMBERING .....</b>	<b>156</b>
12.6.1. MMX8x8-HDMI-4K-A .....	156
12.6.2. MMX8x8-HDMI-4K-A-USB20.....	156
<b>12.7. CONDITIONS IN THE WIZARD TAB OF THE EVENT MANAGER.....</b>	<b>157</b>
<b>12.8. ACTIONS IN THE WIZARD TAB OF THE EVENT MANAGER.....</b>	<b>157</b>
<b>12.9. HASHTAG KEYWORD LIST .....</b>	<b>159</b>
<b>12.10. FIRMWARE RELEASE NOTES .....</b>	<b>160</b>
<b>12.11. APPLIED PORTS (NETWORK SETTINGS).....</b>	<b>161</b>
<b>12.12. FACTORY EDID LIST.....</b>	<b>162</b>
<b>12.13. CABLE WIRING GUIDE.....</b>	<b>163</b>
<b>12.14. FURTHER INFORMATION.....</b>	<b>164</b>

# 1

## Introduction

Thank you for choosing Lightware's MMX8x8-HDMI series device. In the first chapter we would like to introduce the devices, highlighting the most important features in the sections listed below:

- ▶ DESCRIPTION
- ▶ BOX CONTENTS
- ▶ MODEL COMPARISON
- ▶ FEATURES
- ▶ TYPICAL APPLICATION



## 1.1. Description

MMX8x8-series is a standalone matrix switcher specifically designed for collaboration room environments. It has eight video inputs and eight video outputs. 4K / UHD (30Hz RGB 4:4:4, 60Hz YCbCr 4:2:0), 3D capabilities and HDCP are fully supported.

MMX8x8-HDMI-4K-A has six balanced, 5-pole Phoenix audio inputs or outputs for embedding or de-embedding purposes.

MMX8x8-HDMI-4K-A-USB20 is an integrator-friendly, 8x8 matrix switcher for HDMI video and USB2.0 peripherals. It has eight HDMI inputs and eight independent HDMI outputs, as well as a USB 2.0 layer that provides the switching of four external USB peripherals (such as webcam, speakerphone, multitouch display, etc.) to four independent computers or laptops.

The units can be controlled via RS-232, Ethernet or USB ports, but they also offer RS-232, Serial and IR command injection capabilities allowing to send any control command directly to end points.

### 1.1.1. Compatible Devices

The matrix switchers are compatible with other Lightware devices, matrix boards, third-party extenders, displays, but not compatible with the phased out TPS-90 extenders.

#### About the Serial Number



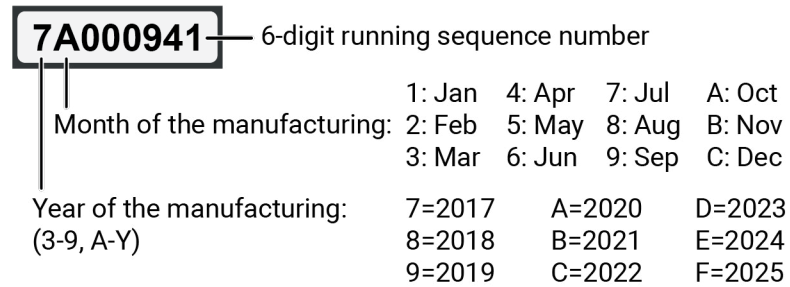

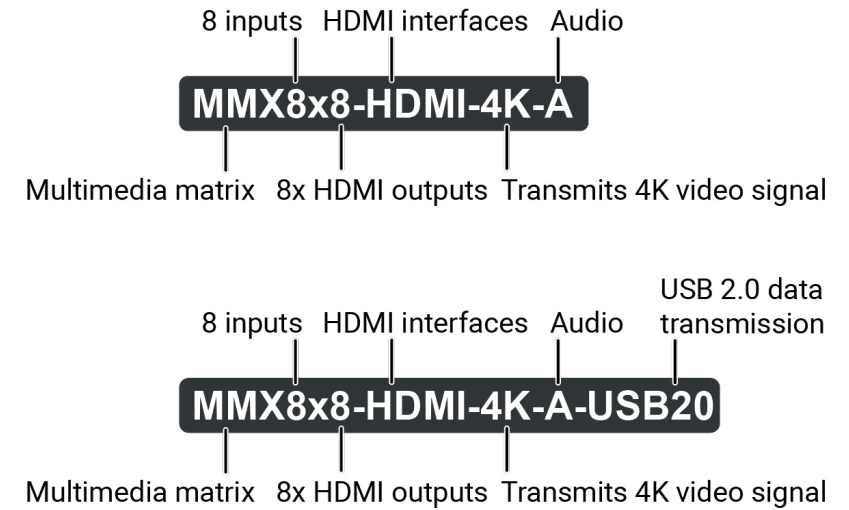

Lightware devices contain a label indicating the unique serial number of the product. The structure is the following:



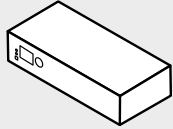

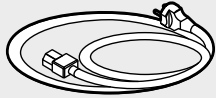
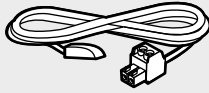

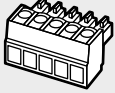
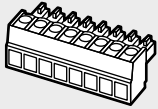
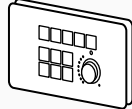





### Model Denomination

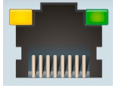

### 1.2. Box Contents

	Supplied Accessories						Optional accessories		
									
MMX8x8-HDMI-4K-A	✓	✓	✓	2x	2x	6x	✗		
MMX8x8-HDMI-4K-A-USB20	✓	✓	✓	2x	2x	6x	1x		

### 1.3. Model Comparison

	Inputs	Outputs	I/O	Control Ports					USB		Front panel	
	HDMI	HDMI	Audio (HDMI)	Control Ethernet RJ45	IR out 3.5 mm Jack	TTL/IR 2-pole Phoenix	Serial 3-pole Phoenix	GPIO 8-pole Phoenix	USB Type-A	USB Type-B	I/O buttons	LCD menu
												
MMX8x8-HDMI-4K-A	8x	8x	6x	✓	2x	2x	2x	✗	✗	✗	✓	✓
MMX8x8-HDMI-4K-A-USB20	8x	8x	6x	3x	2x	2x	2x	✓	4x	4x	✓	✓

## 1.4. Features

### 1.4.1. List of Features

**DIFFERENCE:** The availability of the features are device-dependent, see the table at the following page.



#### 4K and 3D Support

High bandwidth allows extension of resolutions of up to 4K and even 3D sources and displays are supported.



#### Advanced EDID Management

Any EDID can be emulated on the inputs independently, read and store the attached monitor's EDID in internal memory, upload and download EDID files using Lightware Device Controller.



#### Audio Embedder and De-embedder Function

The analog audio can be embedded into HDMI outputs and embedded audio can be routed to the analog audio output.



#### Basic IT-security

These entry-level network security improvements help prevent unauthorized access to the Lightware device: cleartext login, TCP port blocking and MAC address filtering.



#### Batch of Commands

A batch of LW3 commands (salvo) can be run by the Lightware device either by a previously stored macro or by sending a file to the device with the desired commands.



#### Consumer Electronics Control (CEC)

Supports transmitting standard CEC commands in order to remote control the source or sink device.



#### Event Manager

The Event Manager tool takes care of all the necessary control in a smaller configuration by performing predefined actions in response to device status changes.



#### Event Manager +

Triggering a condition, defining variables and checking two conditions for an action – these features are available via the improved Event Manager.



#### Frame Detector

The exact video and audio signal format can be determined such as timing, frequencies, scan mode, HDCP encryption, color range, color space and audio sample rate.



#### Graphic Display and Rotary Jog Dial Control Knob

Easy setting and menu navigation are assured by the color graphic display and the comfortable jog dial control.



#### GPIO Control Port (only for MMX8x8-HDMI-4K-A-USB20)

6 GPIO pins that operate at TTL digital signal levels and can be controlled with both LW2 and LW3 commands.



#### HDCP-compliant

The receiver fulfills the HDCP standard. HDCP capability on the digital video inputs can be disabled when non-protected content is extended.



#### Infra Code Sending

IR code sending in Pronto Hex format – in Command injection mode, too. The code sending is available as an Action in Event manager, too.



#### Miniweb

The Miniweb is able to display an adaptive surface with a virtual crosspoint and buttons for Event manager Actions. The miniweb can be displayed in a mobile device, too.



#### Pixel Accurate Reclocking

Each output has a clean, jitter free signal, eliminating signal instability and distortion caused by long cables or connector reflections.



#### RS-232 Recognizer

Support recognizing incoming RS-232 messages to integrate with 3rd party devices like the video conference codec devices.



#### TCP Recognizer



















Support recognizing the incoming TCP messages to integrate with 3rd party devices like the video conference codec devices.



#### USB 2.0 Switch – 4x1 (MMX8x8-HDMI-4K-A-USB20)

The USB 2.0 layer provides the switching of four external USB peripherals (e.g. webcam, speakerphone, multitouch display, etc.) to four independent host computers or laptops.

1.4.2. Feature Availability

	Basic Features														Advanced Control Pack v3 (from firmware pack v1.3.0)			
																		
	4K and 3D Support	Advanced EDID Management	Audio Embedder and De-embedder Function	Consumer Electronics Control (CEC)	Event Manager	Frame Detector	Graphic Display and Rotary Jog Dial Control Knob	GPIO Control Port	HDCP-compliant	Infra Code Sending	Miniweb	Pixel Accurate Reclocking	RS-232 Recognizer	USB 2.0 Switch – 4x1	Basic IT Security	Batch Commands	Event Manager +	TCP Recognizer
MMX8x8-HDMI-4K-A	✓	✓	✓	✓	✓	✓	✓	⊘	✓	✓	✓	✓	✓	⊘	✓	✓	✓	✓
MMX8x8-HDMI-4K-A-USB20	✓	✓	✓	✓	✓	✓	✓	✓	✓	✓	✓	✓	✓	✓	✓	✓	✓	✓

### 1.5. Typical Application

#### MMX8x8-HDMI-4K-A

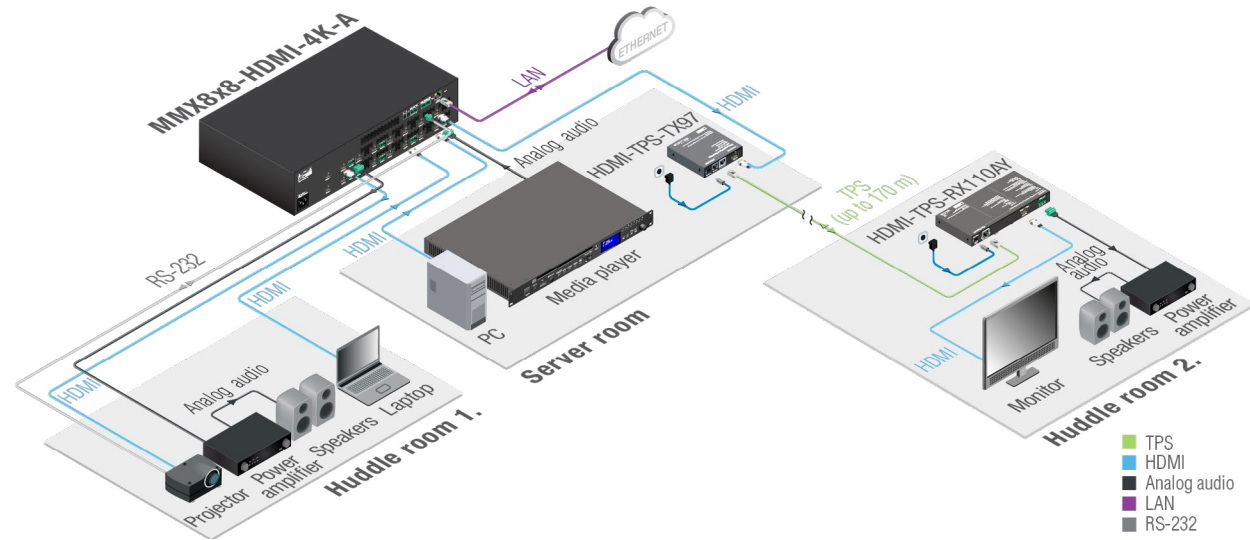

**MMX8x8-HDMI-4K-A-USB20 - Small room application**

#new

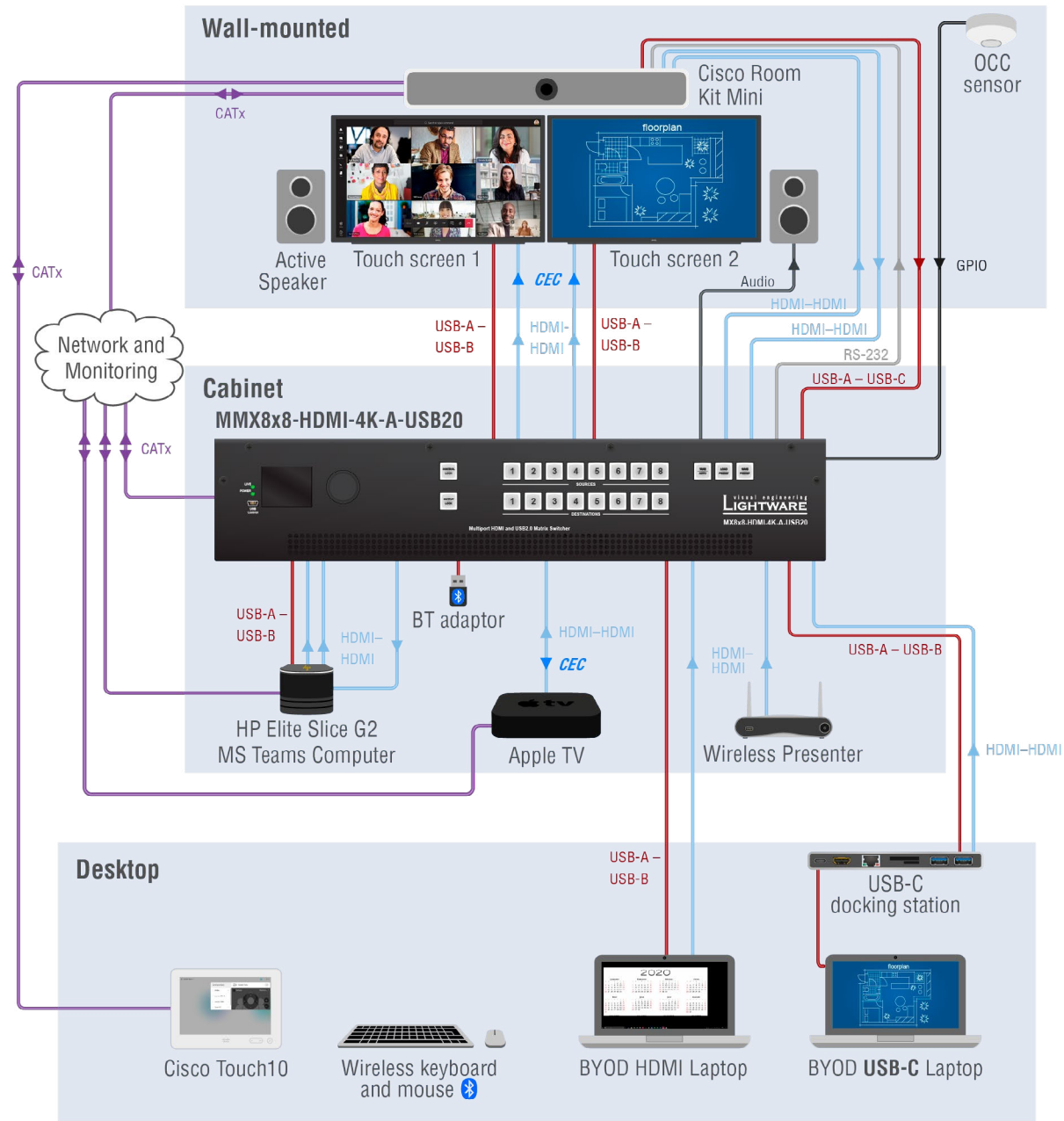

**MMX8x8-HDMI-4K-A-USB20 - Divisible room application**

#new

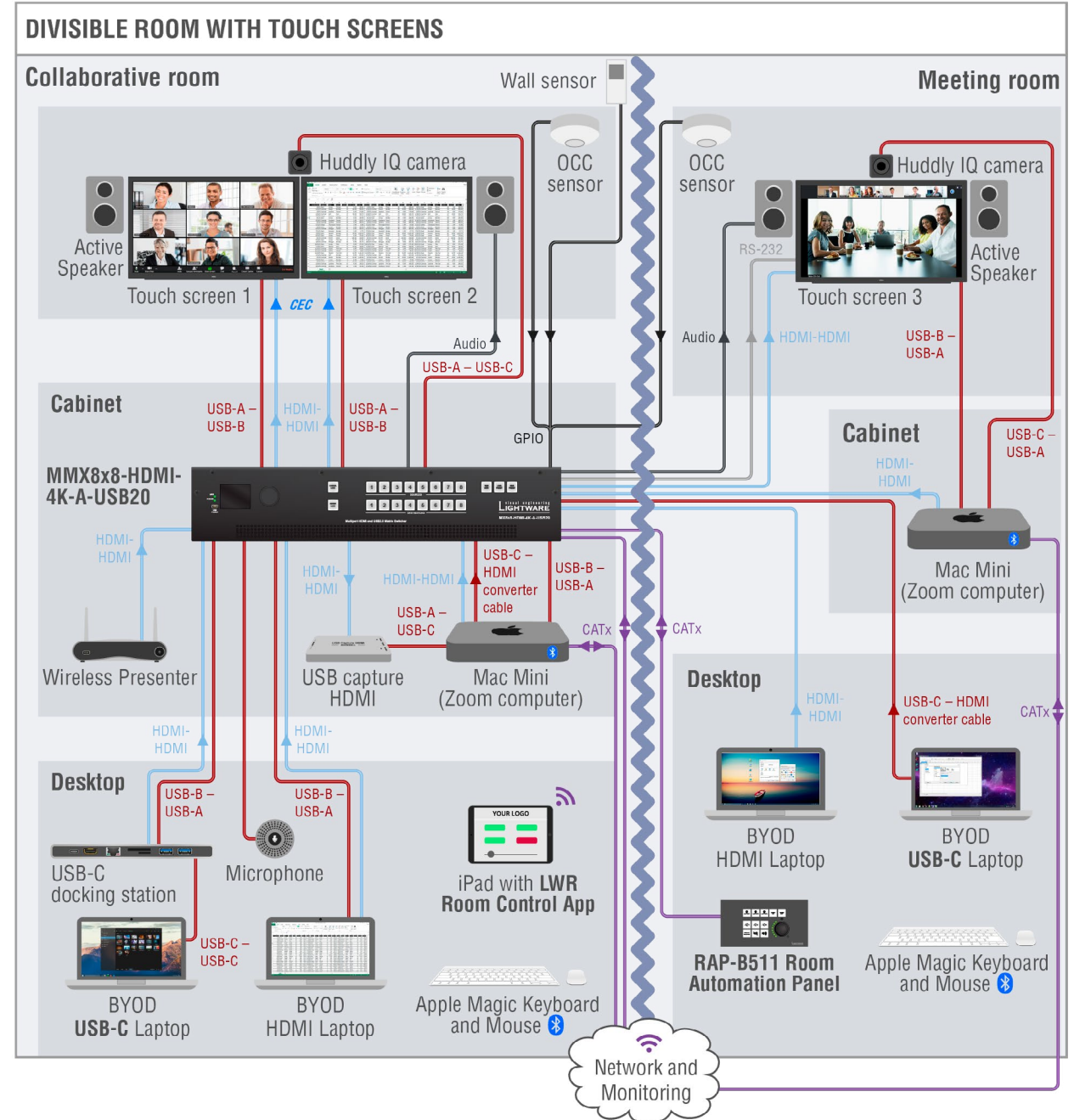

# 2

## Product Overview

The following sections are about the physical structure of the device, input/ output ports and connectors:

- ▶ [FRONT VIEW](#)
- ▶ [REAR VIEW](#)

## 2.1. Front View

All Models #new

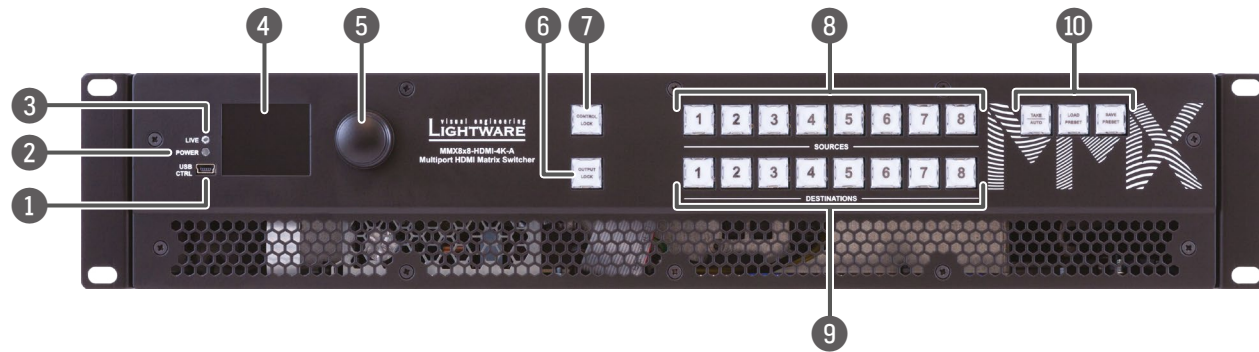

INFO: Both models have the same look and controls on the front panel.

- |   |  |
|---|--|
| <p><b>1 USB Port</b></p> <p><b>2 POWER LED</b></p> <p><b>3 LIVE LED</b></p> <p><b>4 LCD Display</b></p> <p><b>5 Jog Dial Knob</b></p> <p><b>6 Output Lock</b></p> <p><b>7 Control Lock</b></p> <p><b>8 Sources</b></p> <p><b>9 Destinations</b></p> <p><b>10 Function Buttons</b></p> | <p>USB connector for local control functions (e.g. Lightware Device Controller software).</p> <p> <input checked="" type="radio"/> on      POWER LED indicates that the unit is powered on.<br/> <input type="radio"/> off      The unit is powered off or there is an internal voltage problem.         </p> <p> <input checked="" type="radio"/> blinking slow      The unit is on and operates properly.<br/> <input checked="" type="radio"/> blinking fast      The unit is in bootload mode.         </p> <p>LCD screen showing the most important settings in the front panel menu.</p> <p>Easy setting and menu navigation by the jog dial control. Keep dialing and clicking while getting feedback on the LCD.</p> <p>Locking one or more outputs.</p> <p>Disable or enable front panel operations. Red light means that the switching and function buttons are disabled.</p> <p>Buttons to select an input, to select a preset number or to view the state of the selected input port.</p> <p>Buttons to select an output or to view the state of an output.</p> <p>Switching between working modes (Take / Autotake) and performing Preset operations.</p> |
|---|--|



## 2.2. Rear View

### MMX8x8-HDMI-4K-A

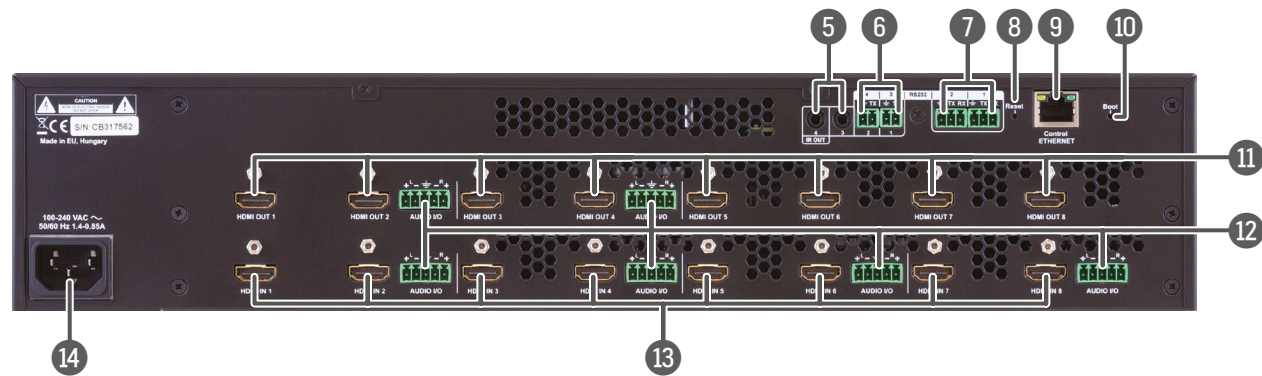

### MMX8x8-HDMI-4K-A-USB20 #new

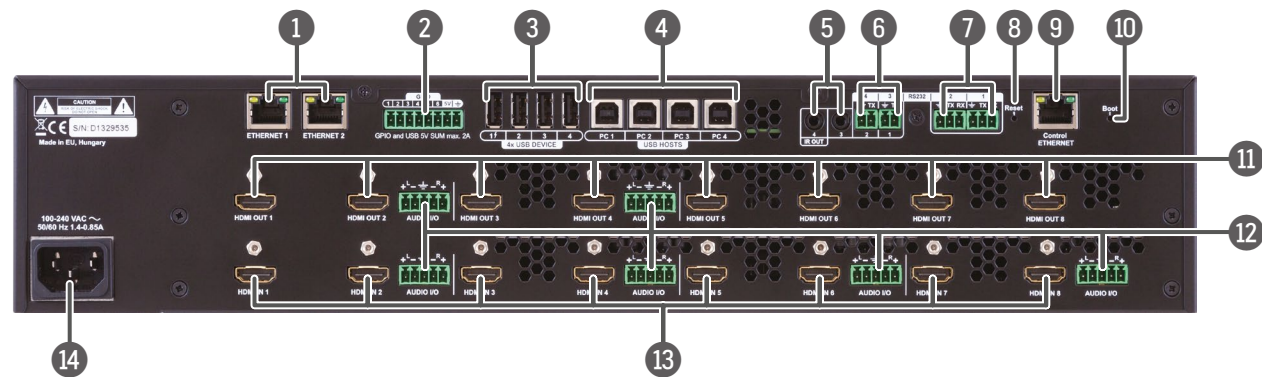

- ① **Ethernet ports** The two RJ45 connectors for Ethernet (to control the unit or to pass-through). They are in the same local network.
- ② **GPIO port** 8-pole Phoenix connector for configurable general purpose input/output ports.
- ③ **USB-A ports** Four USB 2.0 Type-A ports for connecting USB peripherals.
- ④ **USB-B ports** Four USB 2.0 Type-B ports for connecting USB hosts.
- ⑤ **Infra output ports** 3.5 mm TRS connectors (Jack plugs) for infra signal transmission.
- ⑥ **Serial/Infra output ports** 2-pole Phoenix connectors (2x) for IR output or TTL output serial signal.
- ⑦ **RS-232 ports** 3-pole Phoenix connectors (2x) for bi-directional RS-232 communication.
- ⑧ **Reset button** Reboots the matrix; the same as switching it off and on again.
- ⑨ **Control Ethernet port** RJ45 connector to control the matrix via LAN. This is in the same local network with the other Ethernet ports.
- ⑩ **Boot button** Resetting or powering on the device while keeping the hidden button pressed puts the device into bootload mode.
- ⑪ **HDMI outputs** HDMI output connectors for sink devices.
- ⑫ **Audio I/O ports** 5-pole Phoenix connectors for balanced analog audio; depending on the configuration, they can be inputs or outputs. Output audio is the de-embedded HDMI signal from the nearby HDMI port.
- ⑬ **HDMI inputs** HDMI input ports (8x) for sources.
- ⑭ **AC connector** Standard IEC connector accepting 100-240 V, 50 or 60 Hz.

# 3

## Front Panel Control

The following sections are about the front panel operation of the device:

- ▶ [FRONT PANEL LCD MENU OPERATIONS](#)
- ▶ [FRONT PANEL BUTTON OPERATIONS](#)

### 3.1. Front Panel LCD Menu Operations

The front panel has a color LCD that shows the most important settings and parameters structured in a menu. The jog dial control knob can be used to navigate between the menu items or change the value of a parameter. The knob can be pressed to enter a menu or edit/set a parameter.

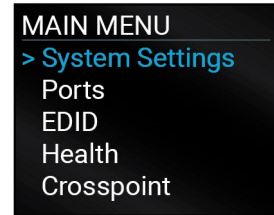

Menu navigation & change parameter



Menu selection & set parameter

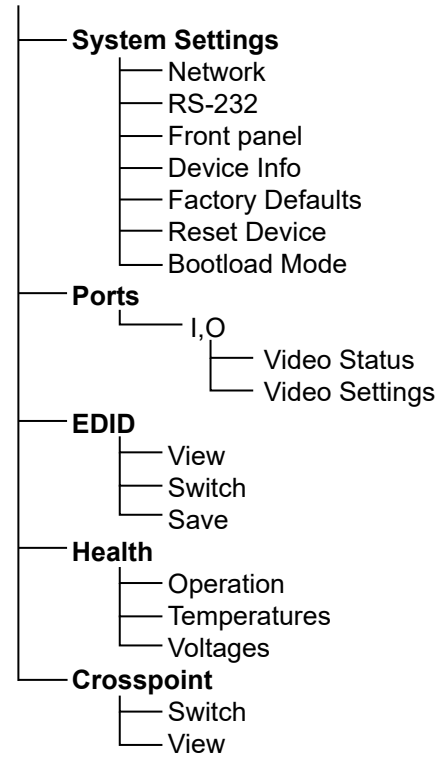
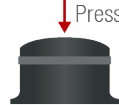

#### Parameter Selection

The **blue** colored line means the selected menu/parameter, the **green** one means the current setting.

**TIPS AND TRICKS:** The faster you rotate the jog dial, the faster the parameter list is scrolled.

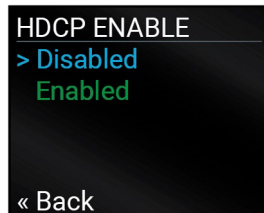

### 3.1.1. System Settings Menu

#### Network Submenu

#dhcp #ipaddress #network

The parameters of the network connection can be set in this submenu. IP, Subnet, Gateway and MAC parameters show the current settings. If the DHCP option is disabled, three more parameters are listed that can be set for a static IP address:

- Static IP,
- Static Subnet,
- Static Gateway.

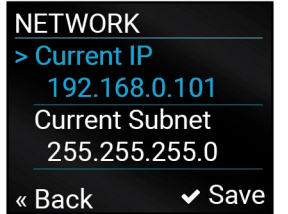

**ATTENTION!** If you change the network settings, always press the Save option under Network menu (not only in the submenu of the parameter) to apply the new settings.

#### RS-232 Submenu

#rs232 #rs-232

When entering the submenu, the available serial ports are listed. Select the desired port and enter to see the settings.

Adjustable parameters of the serial ports:

- Mode (Disconnect/ Control/ Command injection),
- Baud Rate\* (4800/ 7200/ 9600/ 14400/ 19200/ 38400/ 57600/ 115200)
- Protocol (LW2/ LW3).

\*At a Mixed IR /TTL serial port, only this setting is available.

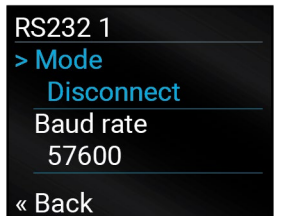

#### Front Panel Submenu

The following front panel-related parameters can be set in this submenu:

- Display Backlight (1-10)
- Rotary Direction (CW Down/ CCW Down)

The brightness of the LCD can be set from 1 to 10 on a scale.

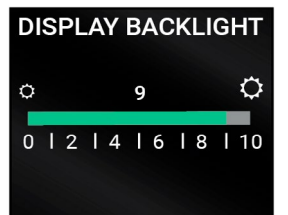

**Device Info Submenu**

#firmwareversion

In this submenu you can check basic information about the matrix unit:

- Serial number
- Hardware Version
- Firmware Version

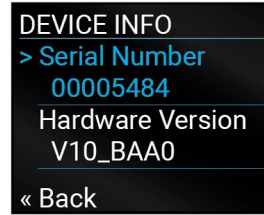

**Factory Defaults Submenu**

#factory

Factory default settings will be restored by choosing **Yes**.

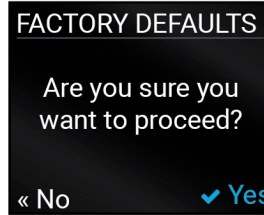

**Reset Device Submenu**

#restart

There is a possibility to reset the device.



**Bootload Mode Submenu**

#bootload

Special function for entering the bootload mode.

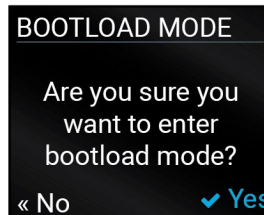

**3.1.2. Ports Menu**

When entering the menu, the available video input and output ports are listed. The icons display information about the port and the video signal (see the table below). Select the desired port and enter to see the submenu.

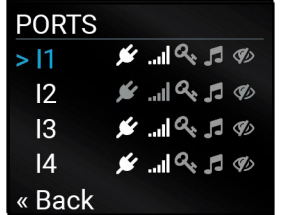

Grey icon	Description	White icon	Description
	Source/sink is <b>not</b> connected		Source/sink is connected
	No audio signal in the video stream		Audio is embedded in the video stream
	Signal is <b>not</b> present		Signal is present
	Signal is <b>not</b> encrypted with HDCP		Signal is encrypted with HDCP
	The port is unmuted		The port is muted

**Video Status Submenu for Input Ports**

The most important properties of the chosen input port can be checked in this submenu:

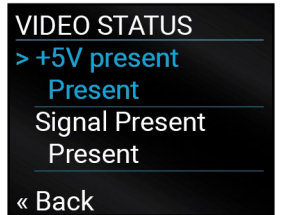

Parameter	Input port
+5V present	Present/ Not present
Signal Present	Present/ Not present/Unknown
HDCP Status	Encrypted/ Not encrypted/Unknown
Embedded Audio	Present/ Not present/Unknown
Pixel Clock (MHz)	No signal/ [x] MHz
Active Resolution	Unknown/ No signal/ [x]x[y][i\ p][f]
Total Resolution	Unknown/ No signal/ [x]x[y]

**Video Settings Submenu for Input Ports**

#hdc

- HDCP Enable (Disabled / Enabled)

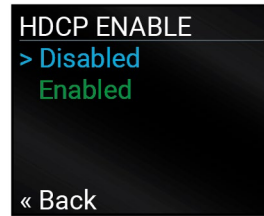

**Video Status Submenu for Output Ports**

The most important properties of the chosen output port can be checked in this submenu:

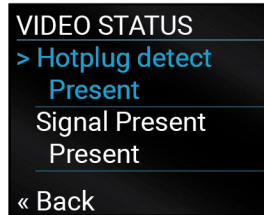

Parameter	HDMI OUTPUT
Hotplug detect	Present/ Not present
Signal Present	Present/ Not present/Unknown
HDCP Status	Encrypted/ Not encrypted/Unknown
Embedded Audio	Present/ Not present/Unknown
Pixel Clock (MHz)	No signal [x] MHz
Active Resolution	Unknown/ No signal [x]x[y][i\p][f]
Total Resolution	Unknown/ No signal/ [x]x[y]

**Video Settings Submenu for Output Ports**

#signaltype #hdc

- Signal type (Auto / DVI / HDMI)
- +5V Enable (Always on / Always off / Auto)
- HDCP Mode (Auto / Always on)

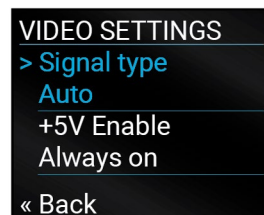

**3.1.3. EDID Menu**

Advanced EDID Management is available in the front panel LCD menu, which allows viewing, switching or saving an EDID to the User EDID memory. See more information about EDID technology in [EDID Management](#). The EDID memory structure of the device can be found in the [Sources and Destinations](#) chapter.

**View Submenu #edid**

Select the desired EDID memory block: **Factory EDIDs**, **Last Attached EDIDs**, **User EDIDs**, or **Emulated EDIDs**. Select the **Name** item and press the knob. Use the jog dial to step between the EDIDs. The following information can be checked:

- Preferred Resolution
- Monitor Name
- Audio Info

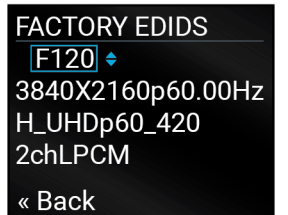

**Switch Submenu**

The submenu looks similar to the View submenu, but in this case the Destination is also listed. To change an EDID, do the following:

- Step 1.** Navigate to the **EDID/Switch** submenu.
- Step 2.** Select the **Name** item and press the knob. Use the jog dial to select the desired **EDID** (Factory EDIDs, User EDIDs, or Dynamic EDIDs) and press the knob.
- Step 3.** Select the **Destination** item and press the knob. Use the jog dial to select the desired **EDID memory** (Emulated EDIDs, All) and press the knob.
- Step 4.** Navigate to the **Switch** option and press the knob.



### Save Submenu

The EDID of a connected sink can be saved to the User EDID memory as follows:

**Step 1.** Navigate to the EDID/Save submenu.

**Step 2.** Select the **Name** item and press the knob. Use the jog dial to select the desired **EDID** (Dynamic EDID) and press the knob.

**Step 3.** Select the **Destination** item and press the knob. Use the jog dial to select the desired **EDID memory** (User EDIDs) and press the knob.

**Step 4.** Navigate to the **Save** option and press the knob.

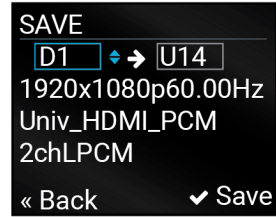

### 3.1.4. Health Menu

#### Operation Submenu

The following information is displayed about the matrix unit in this menu:

- Uptime: the time that passed since the last booting.
- Operation time: displays the summary of the operation hours.

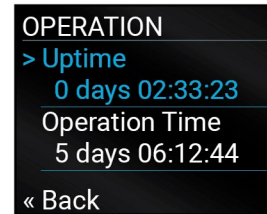

#### Temperatures Submenu

This submenu gives a feedback about the current temperatures of the internal parts in the unit:

- CPU / System / Air intake / Crosspoint / Power Supply

#### Voltages Submenu

The following information is displayed in the Voltages Submenu:

- Main 5V
- Main 3.3V

### 3.1.5. Crosspoint Menu

Crosspoint settings can be viewed and switched in the front panel LCD menu.

#### Switch Submenu *#crosspoint #switch*

In the left column, the inputs are listed and the outputs are displayed in the right column. If the frame of the column is blue, it means it is active, so navigation and selection with the jog dial is possible.

**Step 1.** Navigate to the **Crosspoint/Switch** submenu.

**Step 2.** Use the jog dial to select the desired **Input port** item and press the knob.

**Step 3.** Use the jog dial to select the desired **Output port** item and press the knob. Crosspoint switching performed immediately.

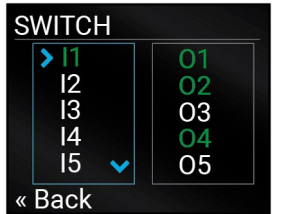

The green color shows the outputs that are already connected. To disconnect the output, select it and press the knob (text color becomes white).

**INFO:** When the selected port is locked, the switching will not be performed.

#### View Submenu

In the left column all the inputs and outputs are listed. The ports connected to the selected one (green colored) are listed in the right column.

**TIPS AND TRICKS:** The appearing arrows show there is more information to display; scroll with the jog dial.

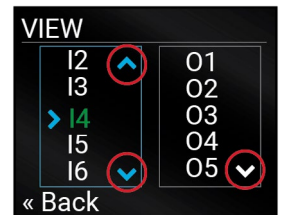
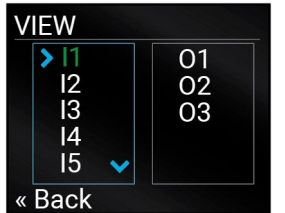

## 3.2. Front Panel Button Operations

### 3.2.1. Control Lock

**DEFINITION:** The Control Lock means to disable the front panel buttons and the jog dial.

While the front panel buttons are disabled, the RS-232, USB and Ethernet control is still enabled. If the button is not illuminated, front panel button operations are enabled. If it continuously shines red, front panel operations are inhibited (including the LCD menu).

Press and hold the **Control lock** button for three seconds to toggle the control lock state. *#buttonlock*

### 3.2.2. Take / Autotake Modes

The router has two different switching modes: **Take** and **Autotake**. If the **Take / Auto** button is unlit, **Take** mode is active. When the **Take / Auto** button continuously shines green, **Autotake** mode is selected.

Press and hold the **Take** button for three seconds to toggle between **Take** and **Autotake** modes.

#### Take Mode

**DEFINITION:** The **Take** mode allows the user to connect or disconnect multiple outputs to an input at once, but the layout must be confirmed (executed) by the **Take** button as a final step. This mode is useful when time delay is not allowed between multiple switching.



The commands are only realized when the **Take** button is pressed. If no button is pressed for two seconds, all preselected actions (which were not realized by pressing **Take**) will be ignored, and the router returns to its idle state.

#### Autotake Mode

**DEFINITION:** The **Autotake** mode means the switching actions are executed immediately (without user confirmation). *#autotakemode*



The switching occurs immediately upon pressing one of the input selector buttons.

### 3.2.3. View Crosspoint State

The current switching status can be checked on the front panel by using the front panel buttons. The crosspoint state is displayed slightly differently in **Take** or **Autotake** modes because of the different switching methods.

**INFO:** View mode does not mean that the router has to be switched into a different mode, viewing and switching can be done after each other, without pressing any special buttons.

#### View Current State in Take Mode

If the router is in **Take** mode, the user can verify both input and output connections. In **Take** mode no accidental change can be done unless the **Take** button is pressed.

Press and release a **source button**. Now the selected source button and all destination buttons that are currently connected to the selected source will light up. This informative display will remain active for three seconds, then all buttons turn to dark.

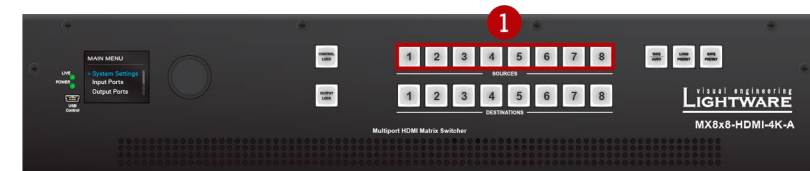

If every source, destination, and **Take** buttons are unlit (the unit is in **Take** mode, and no input was selected in the last 3 seconds), press and release a **destination button** to see its current state. Now the source button that is connected to the selected destination will light up.



#### View Current State in Autotake Mode

In **Autotake** mode only the states of the destinations can be viewed.

Press and release the required **destination button**. Now the source button that is connected to the selected destination will light up.

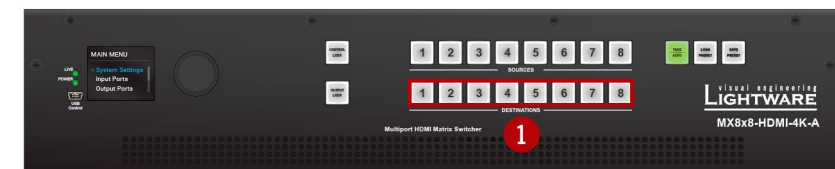

### 3.2.4. Switching Operations

#### Switching in Take Mode *#crosspoint #switch*

Take mode allows the user to connect or disconnect multiple outputs to an input at once. This mode is useful when the time delay is not allowed between multiple switching. The commands are only realized when the **Take** button is pressed.

- Step 1.** First, press and release the desired **source button**. The pressed source button and all destination buttons that are currently connected to the source lights up.
- Step 2.** Press and release the desired **destination buttons** that need to be (dis)connected to/from the selected source. The preselected destination buttons will blink. If no button is pressed for three seconds, the buttons will turn to dark.
- Step 3.** Press and release the **Take** button; the selected input is switched to the selected output(s).

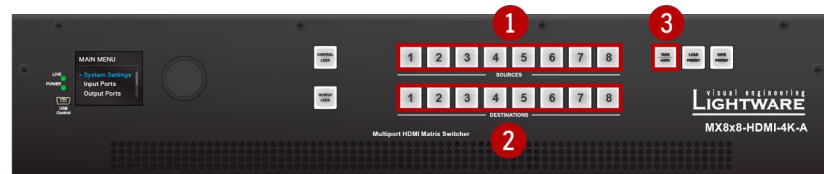

#### Switching in Autotake Mode

Autotake mode is useful when immediate actions must be done or fast switching is needed between sources on a particular destination. In this mode switching occurs immediately upon pressing one of the input selector buttons.

- Step 1.** Press and release the desired **destination button**. The pressed destination button and the currently connected source button light up green. If no source is connected (the output is muted), no source button will light up.
- Step 2.** Press and release the desired **source button**. The switch action will be executed immediately. Switching between sources to the selected destination can be done directly.

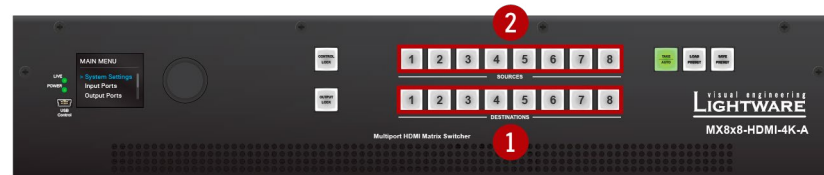

### 3.2.5. Output Lock

**ATTENTION!** Even though the front panel buttons allow locking only the output ports, the input ports can also be locked by using the Lightware Device Controller software (see the [HDMI Output Port Properties](#) section) or sending LW3 protocol commands (see the [Locking an Output Port](#) section).

By using Lightware routers, it is possible to lock a destination. This feature prevents an accidental switching to the locked destination in case of an important signal. Locking a destination means that no input selection or muting action can be executed on that particular destination. *#buttonlock*

Destinations can be independently locked or unlocked. Locking a destination does not affect other destinations.

#### Output Lock in Take Mode

- Step 1.** Press and release the **Output Lock** button; it starts to blink and all the buttons of any locked destinations light up (view state).
- Step 2.** Press and release a **destination button**; it starts to blink (more destinations can be selected sequentially).
- Step 3.** Press and release the **Take** button. The selected destinations are now locked.

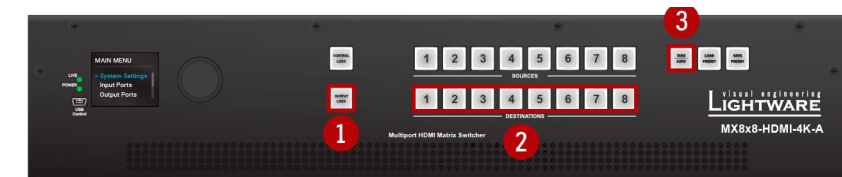

#### Output Lock in Autotake Mode

- Step 1.** Press and release the required **destination button**. Now the selected destination button and the currently configured source button light up (view mode).
- Step 2.** Press and release the **Output Lock** button; it lights up in red, and lock function is activated at once. No source can be changed at the locked destination. *#buttonlock*





### 3.2.6. Control Lock

Front panel button operation can be enabled or disabled using the **Control Lock** button, while the remote control is still enabled. If the button is unlit, front panel button operation is enabled. If the button is continuously shining in red, the front panel operations are not possible. Press and keep the **Control Lock** button pressed for three seconds to toggle between the control lock states. *#buttonlock*

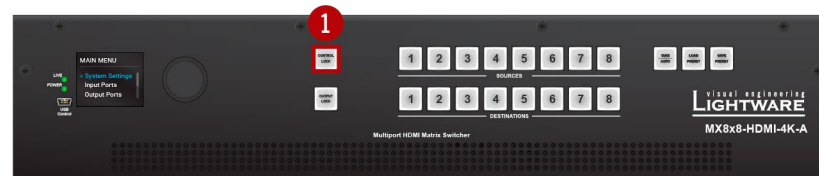

### 3.2.7. Save or Load a Preset

The matrix can store user-programmable presets. Each preset stores a configuration regarding all input connections for all outputs. All presets are stored in a non-volatile memory; the router keeps the presets even in the case of a power down. Please note that preset operations can be followed on the LCD during front panel preset operations.

**ATTENTION!** Eight of the memory slots are available by the Source buttons; see the [Presets Tab](#) for the details.

#### Saving a Preset in Take Mode

- Step 1.** Press and release the **Save Preset** button.
- Step 2.** Press and release the desired **source (memory address) button** (source 1 to 8).
- Step 3.** Press and release the **Take** button. Now the current configuration is stored in the selected memory.

**ATTENTION!** Preset save action always stores the current configuration for all outputs.

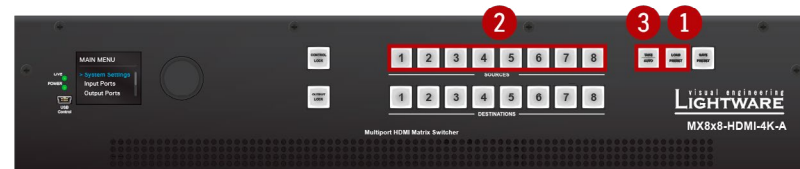

#### Loading a Preset in Take Mode

- Step 1.** Press and release the **Load preset** button.
- Step 2.** Press and release the desired **source (memory address) button** (source 1 to 8).
- Step 3.** Press and release the **Take** button. Now the selected preset is loaded.

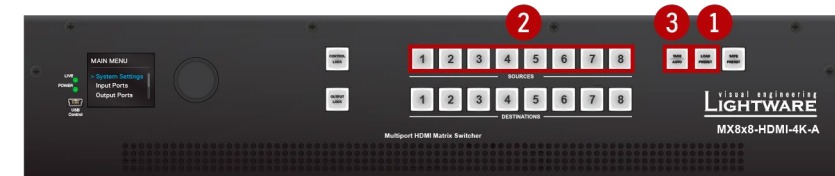

#### Saving a Preset in Autotake Mode

- Step 1.** Press and release the **Save Preset** button.

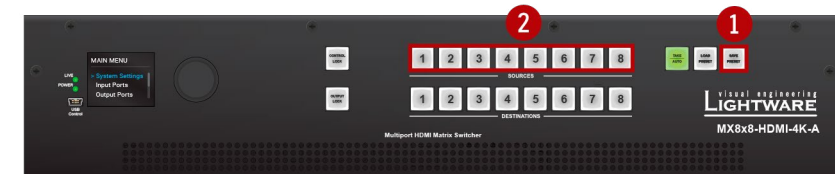

- Step 2.** Press and release the desired **source (memory address) button** (source 1 to 8). Now the current configuration is stored in the selected memory.

**ATTENTION!** Preset save action always stores the current configuration for all outputs.

#### Loading a Preset in Autotake Mode

- Step 1.** Press and release the **Load Preset** button.
- Step 2.** Press and release the desired **source (memory address) button** (source 1 to 8). Now the selected preset is loaded.



### View Locked Outputs



### View Locked State of an Output



### Lock/Unlock an Output



# 4

## Installation

The chapter is about the installation of the device and connecting to other appliances, presenting also the mounting options and further assembly steps.

- ▶ [MOUNTING OPTIONS -STANDARD RACK INSTALLATION](#)
- ▶ [ELECTRICAL CONNECTIONS](#)
- ▶ [CONNECTING STEPS](#)
- ▶ [POWERING ON](#)

### 4.1. Mounting Options -Standard Rack Installation

The matrix can be mounted in several ways by the supplied two rack ears. Allen head screws fix them to the housing.

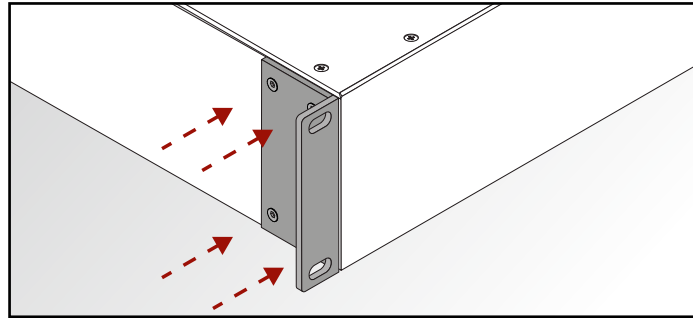

**ATTENTION!** M4x10 size is the longest allowed screw for fixing the ears to the housing. A longer screw may touch internal parts.

Two rack ears are supplied with the product, which are fixed on left and right side as shown in the picture. The default position allows mounting the device as a standard rack unit installation.

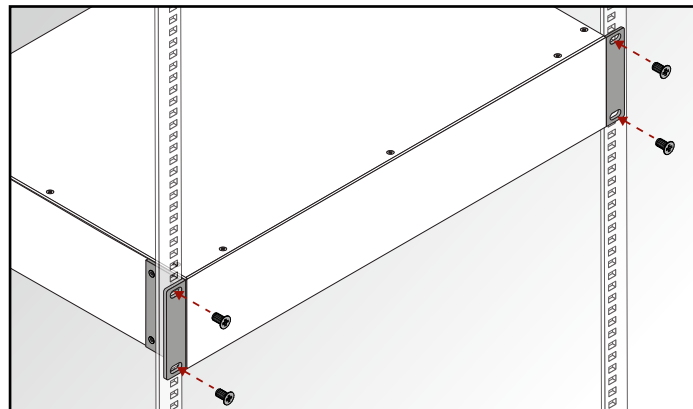

**Standard rack installation**

**ATTENTION!** Always use all the four screws for fixing the rack shelf ears to the rack rail. Choose properly sized screws for mounting. Keep a minimum of two threads left after the nut screw.

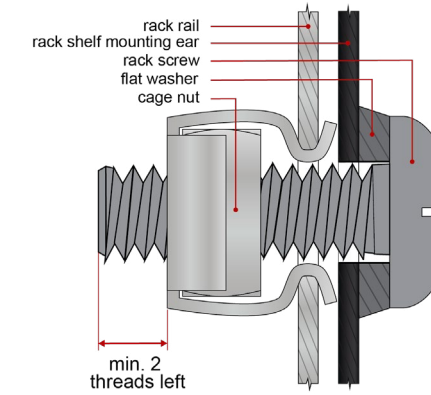

**Mounting the device to the rack rail**

**INFO:** The matrix switcher is one rack wide and 2U high.

**ATTENTION!** Never block the ventilation holes on any side of the matrix! Ensure the proper ventilation by letting the air flow freely.

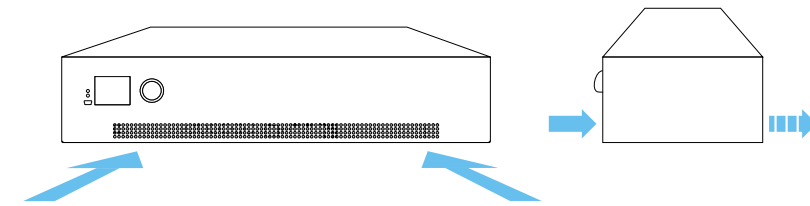

**Direction of the airflow**

## 4.2. Electrical Connections

### 4.2.1. HDMI Input and Output Ports

The matrix switchers are assembled with standard 19-pole HDMI connectors with screw lock for inputs and outputs. Always use high quality HDMI cables for connecting sources and displays.



### 4.2.2. Analog Stereo Audio

5-pole Phoenix connectors are used for balanced analog audio input or output. Unbalanced audio signals can be connected as well. See more details about the balanced and unbalanced I/O port wiring in the [Cable Wiring Guide](#) section.



Pin nr.	Signal
1	Left+
2	Left-
3	Ground
4	Right-
5	Right+

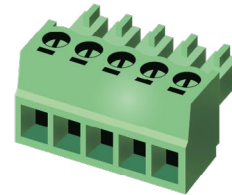

**Analog audio connector and plug pin assignments**

#### Compatible Plug Type

Phoenix® Combicon series (3.5mm pitch, 5-pole), type: MC 1.5/5-ST-3.5.

### 4.2.3. RS-232 Connector

The receiver contains a 3-pole Phoenix connector, which is used for RS-232 serial connection.



Pin nr.	Signal
1	Ground
2	TX data
3	RX data

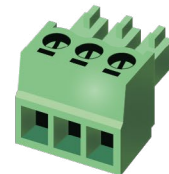

**RS-232 connector pin assignments**

#### RS-232 Output Voltage Levels

- Logic low level: 3V .. 15V
- Logic high level: -15V .. -3V

#### Compatible Plug Type

Phoenix® Combicon series (3.5mm pitch, 3-pole), type: MC 1.5/3-ST-3.5.

You can find more information about RS-232 in the [Serial Interface](#) section.

### 4.2.4. Infra/ Serial TTL Connector

The matrix switcher contains a 2-pole Phoenix connector. Depending on the destination port, it can be used for TTL serial data output or as an Infra emitter.



Pin nr.	Signal
1	Ground
2	TX data

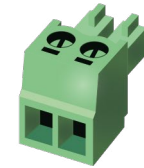

**Infra/ TTL serial connector pin assignments**

TTL digital signal levels can be set to high or low level (Push-Pull).

Using a receiver with at least 1k impedance to any voltage between 0V and 5V, the output voltages are:

- Logic low level: 0 .. 0.25V
- Logic high level: 4.75 .. 5.0V

In that case the actual current is:

- Logic low level: -5mA < current < 0mA (sink)
- Logic high level: 0mA < current < 5mA (source)

#### Compatible Plug Type

Phoenix® Combicon series (3.5mm pitch, 2-pole), type: MC 1.5/2-ST-3.5.

You can find more information about TTL in the [Serial Interface](#) section and about Infrared in the [Infra Interface](#) section.

### 4.2.5. Control Ethernet Port

The matrix contains an RJ45 connector for Ethernet/LAN connection for local control functions.

The Ethernet ports can be connected to a LAN hub, switch or router by a CATx cable. Even though both cable types (straight or cross) are supported and handled by the device, the pin assignment below is recommended.

#### Wiring of LAN Cables

Lightware recommends the termination of LAN cables on the basis of TIA/EIA T 568 A or TIA/EIA T 568 B standards.

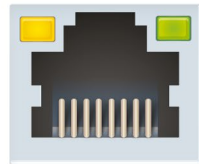

Pin	TIA/EIA T568A	TIA/EIA T568B
1	white/green	white/orange
2	green	orange
3	white/orange	white/green
4	blue	blue
5	white/blue	white/blue
6	orange	green
7	white/brown	white/brown
8	brown	brown

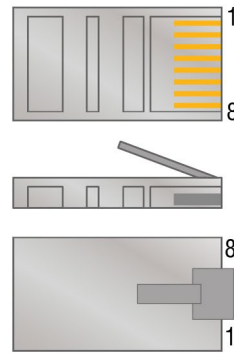

LED	Color	State	Meaning
LED1	green	on	100 Mbit/s
		off	0 Mbit/s
LED2	amber	on	no activity
		off	not linked
		blinking	activity

### 4.2.6. IR Connector

An IR emitter can be connected to the matrix switcher with TRS (Tip, Ring, and Sleeve) connectors. They are also known as (3.5 mm or approx. 1/8") audio jack, phone jack, phone plug, and mini-jack plug.

The pin assignments are the following:

**EMITTER: 2-pole TS**

Pin nr.	Signal
1 Tip	+5V
2 Ring	Signal (active low)
3 Sleeve	

- INFO: Ring pole of the emitter is optional. If your IR emitter has a three pole- TRS plug, then the Ring and the Sleeve are the same signal (Output -).
- INFO: You can find more information in the [Infra Interface](#) section.

#### 4.2.7. GPIO - General Purpose Input/Output Ports

**DIFFERENCE:** Only the MMX8x8-HDMI-4K-A-USB20 model has a GPIO connector.

The matrix is supplied with an 8-pole Phoenix connector with six GPIO pins, which operate at TTL digital signal levels and can be set to high or low level (Push-Pull). The direction of the pins can be input or output (adjustable). Voltage ranges for GPIO inputs are the following:

	Input voltage [V]	Output voltage [V]	Max. output current [mA]
<b>Logical low level</b>	0 - 0.8	0 - 0.5V	30
<b>Logical high level</b>	2 - 5	4.5 - 5V	18

**INFO:** The maximum total current for the six GPIO pins is 180 mA.



Pin nr.	Signal
1	Configurable
2	
3	
4	
5	
6	
7	5V
8	Ground

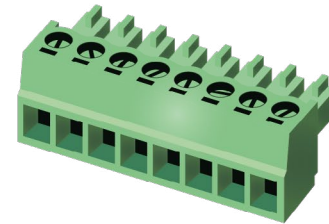

##### *GPIO connector and plug pin assignments*

##### **Compatible plug type**

Phoenix® Combicon series (3.5mm pitch 8-pole), type: MC 1.5/8-ST-3.5.

You can find more information in the [GPIO Interface](#) section.

**INFO:** In the MMX8x8-HDMI-4K-A-USB20 model, the GPIO and USB 5V can be max. 2A altogether.

#### 4.2.8. USB Connector

##### **USB Type-A**

The matrix is supplied with four USB 2.0 compatible A-type ports for connecting USB peripherals. 

5V output power capability can be turned on and off for all ports. The first port is able to supply 1000mA, and the other three are able to power 500mA.

**INFO:** GPIO and USB 5V can be max. 2A altogether.

##### **USB Type-B**

The matrix is supplied with four USB 2.0 compatible B-type ports for connecting USB hosts. 

### 4.3. Connecting Steps

#### MMX8x8-HDMI-4K-A, MMX8x8-HDMI-4K-A-USB20 models

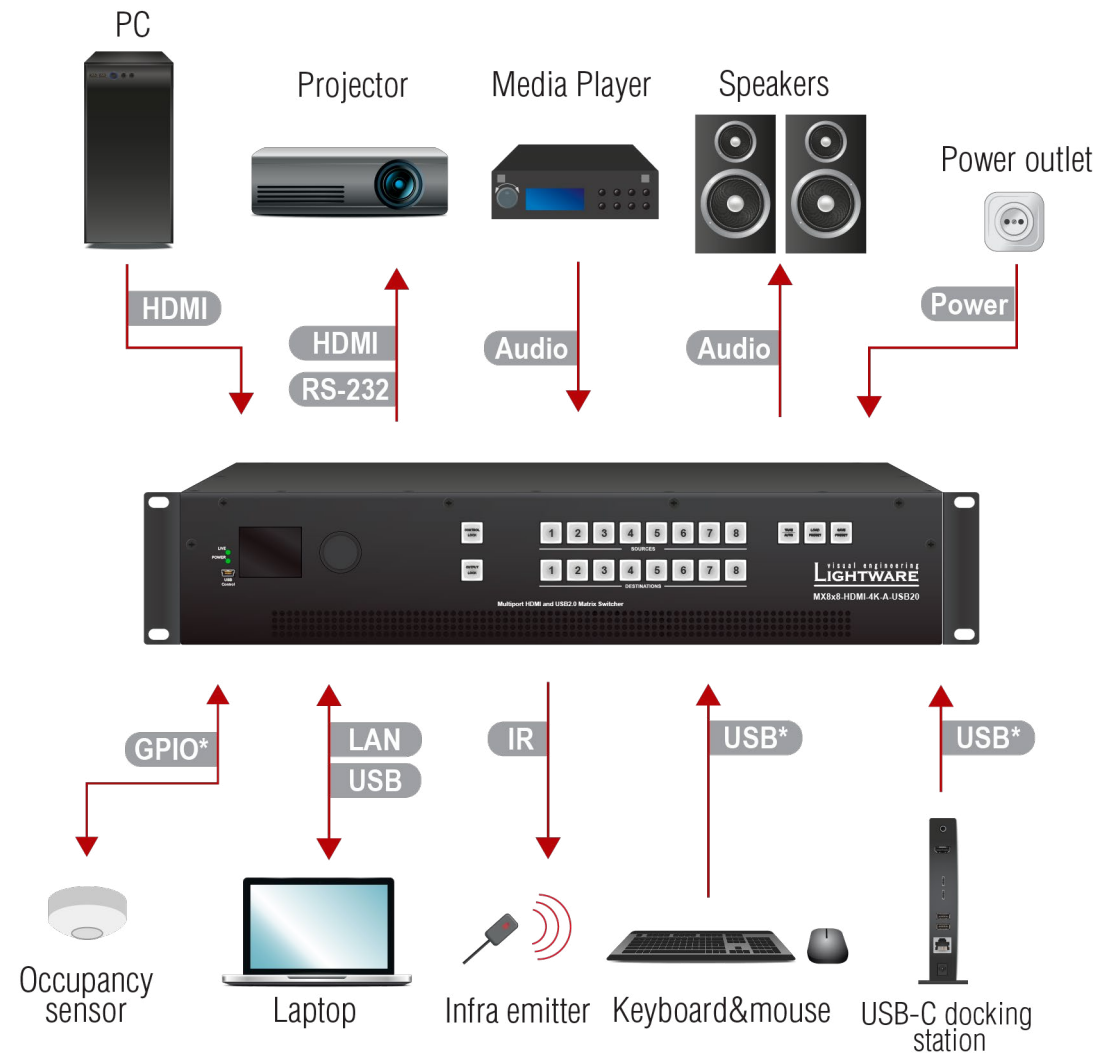

- HDMI** Connect an HDMI source (e.g. PC) to the HDMI input port.
- HDMI** Connect an HDMI sink (e.g. projector) to the HDMI output port.
- Audio** Optionally for analog output: connect an audio device (e.g. speakers) to the analog audio output port by an audio cable.
- Audio** Optionally for audio input: connect an audio source (e.g. media player) to the audio input port by an audio cable.
- RS-232** Optionally connect a serial device (e.g. projector) to the 3-pole Phoenix connector to transmit RS-232 commands.
- USB** Optionally connect a USB cable in order to control the matrix switcher via the Lightware Device Controller software.
- LAN** Optionally connect a UTP cable (straight or cross, both are supported) in order to control the matrix switcher via the Lightware Device Controller software.
- IR** Optionally connect an infra emitter to the infra output port (2-pole Phoenix or 1/8" Stereo Jack connector) to transmit infra signal.
- GPIO** Optionally connect a device (e.g. occupancy sensor) to the GPIO port. \*
- USB** **USB mini-B:** Optionally connect a USB cable in order to control the matrix switcher via the Lightware Device Controller software.  
**USB Type-A\*:** Optionally connect a USB device (e.g. keyboard and mouse).  
**USB Type-B\*:** Optionally connect a USB host (e.g. USB-C docking station).
- Power** Connect the power cord to the AC power socket to the matrix unit. It is recommended to power on the devices as the final step.

\*Only in the MMX8x8-HDMI-4K-A-USB20 model.

### 4.4. Powering On

Connect the power cord to the AC input connector; the matrix is immediately powered on. After the self-test (about 30 seconds), the last configuration is loaded automatically.

**INFO:** The router has an internal emergency memory that stores all current settings and tile configurations. This memory is independent from presets and invisible for the user. This built-in feature helps the system to be ready immediately in case of a power failure or accidental power down.



# 5

## Device Concept

**MMX8x8 series devices are multifunctional audio/video matrix switchers with eight inputs and eight outputs. The matrix makes it possible to route many kinds of signal formats over several available interfaces. This chapter presents the features and limitations of these interfaces.**

- ▶ [HDMI AND TPS MATRIX CONCEPT](#)
- ▶ [VIDEO INTERFACE](#)
- ▶ [AUDIO INTERFACE](#)
- ▶ [ETHERNET INTERFACE](#)
- ▶ [BULK DEVICE MANAGEMENT](#)
- ▶ [INFRA INTERFACE](#)
- ▶ [SERIAL INTERFACE](#)
- ▶ [BATCH COMMANDS](#)
- ▶ [GPIO INTERFACE](#)
- ▶ [CONSUMER ELECTRONICS CONTROL \(CEC\) INTERFACE](#)
- ▶ [THE EVENT MANAGER FEATURE](#)
- ▶ [BASIC IT SECURITY](#)
- ▶ [USB INTERFACE](#)

### 5.1. HDMI and TPS Matrix Concept

#### Summary of Interfaces - MMX8x8-HDMI-4K-A



#### Summary of Interfaces - MMX8x8-HDMI-4K-A-USB20



### 5.2. Video Interface

#### Summary of Video Interfaces

The table below shows the number of the video signals and connector types by model.

Model type	INPUT		OUTPUT	
	Connector type		Connector type	
MMX8x8-HDMI-4K-A	HDMI	8x	HDMI	8x
MMX8x8-HDMI-4K-A-USB20	HDMI	8x	HDMI	8x

The video crosspoint settings can be controlled in any of the following ways:

- Using Lightware Device Controller (for more information, see the [Bulk Device Management](#) section),
- Sending LW2 or LW3 protocol commands, (for LW2 commands, see the [Switching One Input to One Output](#) section, for LW3 commands, see the [Switching and Crosspoint Settings](#) section),
- Using the Autoselect function (for more details, see the [The Autoselect Feature](#) section),
- Using the front panel LCD menu (for more information, see the [Crosspoint Menu](#) section), or
- Pressing the Source and Destination buttons on the front panel\* (see the [Switching Operations](#) section).

\* Only in the MMX8x8-HDMI-4K-A model.

#### 5.2.1. Port Diagram of the MMX8x8-HDMI-4K-A and -USB20 Models

The following figure describes the port diagram of the MMX8x8-HDMI-4K-A and MMX8x8-HDMI-4K-A-USB20 matrix:

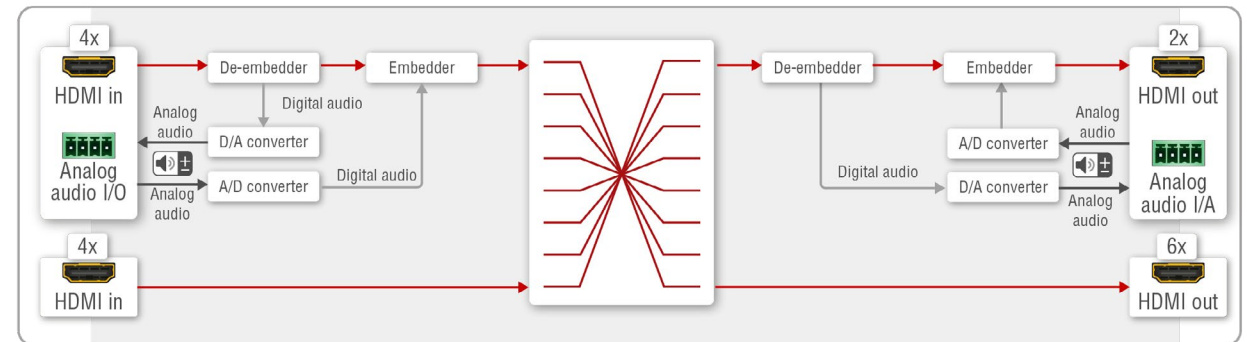

### 5.2.2. The Autoselect Feature

The autoselect mode can be set on output ports for each input with the Lightware Device Controller (LDC) software (see more info about it in the [HDMI Output Port Properties](#) section) or with the LW3 protocol (see more info about it in the [Changing the Autoselect Mode](#) section).

**INFO:** An input port is active if there is a valid signal on it.

There are three types of Autoselect as follows:

**First detect mode:** The selected input port is kept connected to the output while it has an active signal.

**Priority detect mode:** It is always the highest priority active input that is selected to transmit.

The proper priority setting requires fulfilling the conditions below:

- Match the priority to the input ports. 0 means the highest, 7 means the lowest priority. If two inputs have the same priority number, the lower port number gets higher priority.
- Certain inputs can be ignored by clicking on the green tick or writing **31** instead of the priority number. This port will not be scanned. See more details about this setting in the [Querying the Input Port Priority](#) section.
- Always confirm the settings by clicking on the **Set priorities** button.

**Last detect mode:** It is always the last attached input that is selected to transmit.

See the Flowchart of Autoselect Modes in the [Appendix](#) chapter.

**INFO:** Autoselect mode is always disabled on a locked output. If the crosspoint is changed manually, the autoselect function also becomes disabled.

### 5.3. Audio Interface

The table below shows the number of the audio signals and connector types by model.

#### Summary of Audio Interface

Model	Audio inputs	
	HDMI input	Analog audio input <sup>1</sup>
<b>MMX8x8-HDMI-4K-A</b>	8x	6x
<b>MMX8x8-HDMI-4K-A-USB20</b>	8x	6x

Model	Audio outputs	
	HDMI output	Analog audio output <sup>1</sup>
<b>MMX8x8-HDMI-4K-A</b>	8x	6x
<b>MMX8x8-HDMI-4K-A-USB20</b>	8x	6x

<sup>1</sup> Input or output, depending on the configuration. Sum of the analog audio inputs and outputs is six.

#### 5.3.1. MMX8x8-HDMI-4K-A and MMX8x8-HDMI-4K-A-USB20

These models can receive audio from the sources below:

- **HDMI in (embedded audio),**
- **AUX analog audio I/O** (configured as input): This port can be input or output, depending on the configuration. In case of input, the audio will be embedded into the HDMI stream of the port beside it (HDMI In 2, 4, 6, 8 and HDMI Out 2, 4). The output audio ports are:
- **HDMI out (embedded audio):** This is the embedded audio of the incoming video signal.
- **AUX analog audio I/O** (configured as output): This port can be input or output, depending on the configuration. In case of output, the audio will be de-embedded from the HDMI stream of the port beside it (HDMI In 2, 4, 6, 8 and HDMI Out 2,4).

### 5.3.2. General Audio Settings from Inputs to Outputs

The list below contains the main settings of the audio signal from the source to the destination ports in different cases. These properties can be set in the Lightware Device Controller (LDC) software or with LW3 protocol commands.

#### 5.3.2.1. HDMI IN → HDMI OUT

In the first example, the embedded audio of the HDMI signal is transmitted from HDMI in to HDMI out.

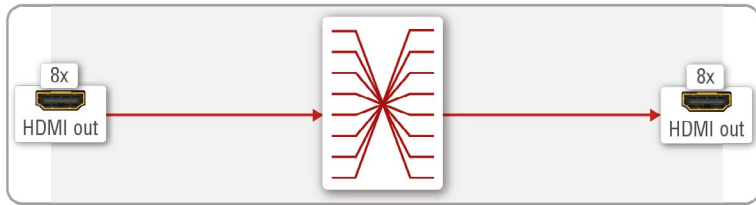

**Crosspoint state:** Switch the desired video input to the desired output. For more details, see the [Crosspoint Operations](#) in the LDC chapter, for LW3 commands, see the [Switching and Crosspoint Settings](#) section.

**Port status:** Unmute the necessary video port. For more details, see the [HDMI Input Port Properties](#) and [HDMI Output Port Properties](#) in the LDC chapter, for LW3 commands, see the [Querying the Status of the Source Port](#) and [Querying the Status of the Destination Port](#) sections.

**Input port properties:** Set the Audio mode to **HDMI audio passthrough**.

This setting can be found only in the I2, I4, I6, I8, O2, O4 ports of the devices.

HDMI audio passthrough is the default audio mode, and this property cannot be changed in the other ports.

#### 5.3.2.2. AUX Analog Audio I/O → HDMI OUT

In the MMX8x8-HDMI-4K-A model

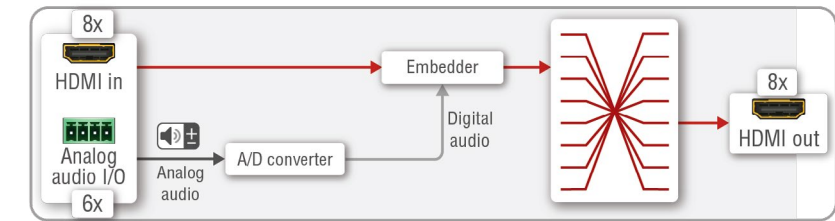

**Crosspoint state:** AUX analog audio I/O belongs to the HDMI port beside it. To transmit the audio signal, set the appropriate video input and output in the video crosspoint. For more details, see the [Crosspoint Operations](#) in the LDC chapter, for LW3 commands, see the [Switching and Crosspoint Settings](#) section.

**Port status:** Check the mute state of the necessary video ports. For more information, see the [HDMI Input Port Properties](#) and [HDMI Output Port Properties](#) in the LDC chapter, for LW3 commands, see the [Querying the Status of the Source Port](#) and [Querying the Status of the Destination Port](#) sections.

**Input port properties:** Set the Audio mode to **Embed from aux audio**, then additional analog audio input settings become available. Take care of the proper mute state, volume and gain values. For LW3 commands, see the [AUX Analog Audio I/O Port Settings](#) section.

**INFO:** Valid video signal is needed for audio transmission, too. The original audio of the HDMI will be replaced with the analog audio.

#### 5.3.2.3. HDMI IN → AUX Analog Audio I/O

In the MMX8x8-HDMI-4K-A model

The de-embedded audio of the HDMI signal can be transmitted to the AUX analog audio I/O port, which is placed beside the HDMI port. No crosspoint setting required.

**Port status:** Check the mute state of the necessary video port. For more details, see the [HDMI Input Port Properties](#) in the LDC chapter, for LW3 commands, see the [Querying the Status of the Source Port](#) section.

**Input port properties:** Set the Audio mode to **Deembedded to aux audio**, then additional analog audio input settings become available. Take care of the proper mute state and volume value.

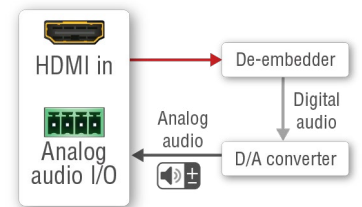

#### 5.3.2.4. AUX Analog Audio I/O → AUX Analog Audio I/O

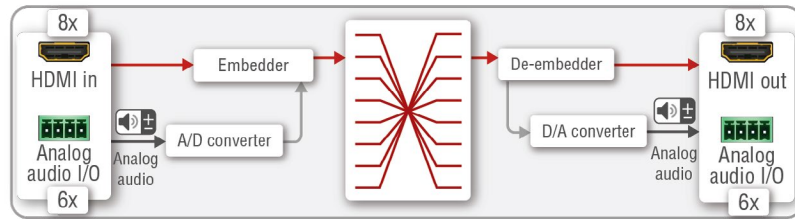

Inputs can be I2, I4, I6, and the outputs can be O2, O4.

**Crosspoint state:** AUX analog audio I/O belongs to the HDMI port beside it. To transmit the audio signal, set the appropriate video input and output in the video crosspoint. For more details, see the [Crosspoint Operations](#) in the LDC chapter, for LW3 commands, see the [Switching and Crosspoint Settings](#) section.

**Port status:** Check the mute state of the necessary video ports. For more details, see the [HDMI Input Port Properties](#) and [HDMI Output Port Properties](#) in the LDC chapter, for LW3 commands, see the [Querying the Status of the Source Port](#) and [Querying the Status of the Destination Port](#) sections.

**Input port properties:** Set the Audio mode to **Embed from aux audio**, then analog audio input settings become available. Take care of the proper mute state, volume and gain values. For LW3 commands, see the [AUX Analog Audio I/O Port Settings](#) section.

**Output port properties:** Set the Audio mode to **Deembed from aux audio**, then analog audio output settings become available. Take care of the proper mute state and volume settings. For LW3 commands, see the [AUX Analog Audio I/O Port Settings](#) section.

## 5.4. Ethernet Interface

The device can be controlled via an Ethernet port (RJ45 connector). This interface supports any third-party system controller with LW2/LW3 command protocol. The interface can be used to configure the device with the Lightware Device Controller and establish the connection to the Lightware Device Updater software and perform firmware update.

Serial and infra messages can be sent and received via the Control Ethernet port (See more details about it in the [Serial Interface](#) and [Infra Interface](#) sections).

### 5.4.1. TCP Recognizer

**DIFFERENCE:** The features mentioned below are available from FW package v1.3.0.

The feature is almost the same as in case of the RS-232, but for the network interface: the incoming TCP messages can be processed, which may trigger actions. The combination of the TCP recognizer and the Event Manager gives numerous opportunities for creating automatic room solutions.

#### TCP Recognizer Example

When the Projector switches off, the button light (1) of the TBP6-EU button panel is turned off automatically.

When the power-off process is started in the projector, it will send a message over Ethernet. That message will be recognized by the matrix switcher and will be used as a Condition in Event Manager.

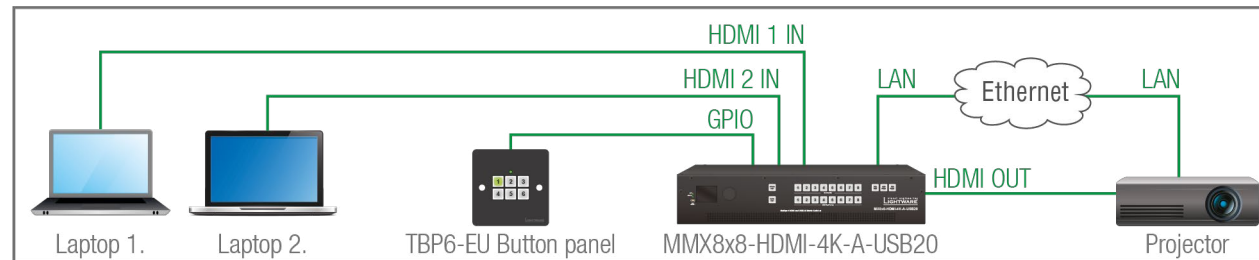

#### How to set up the switcher?

**Step 1.** Configure the recognizer for the communication by the LDC, see the [TCP Clients \(TCP Message Recognizer\)](#) section or by LW3 protocol commands (see the [TCP Message Recognizer](#) section). Define the desired device as a TCP client. (The Projector is saved as 'C1' in this example.)

**Step 2.** Create the following event in the Event manager:

**E1.** When the (PWR!001 "On") message is recognized from the C1 client, the GPIO pin 1 is set to low level.

For more information about setting the events in LDC, see the [Event Manager](#) section.

## 5.5. Bulk Device Management

It is possible to configure several devices at once with the Bulk Device Management tool. This feature can be accessed by clicking on the **Tools** button in the bottom left corner of the Device Discovery window of the LDC and choosing the Bulk Management option. *#new*

See the [Bulk Device Management](#) section for more details.

### 5.5.1. Network Settings

This function makes it possible to change and adjust the network settings of several devices at once (unique settings for each device), without having to set them at each device one by one. A .csv file can be created containing the list and desired settings of the devices and it can be uploaded into the LDC to be applied to the devices quickly.

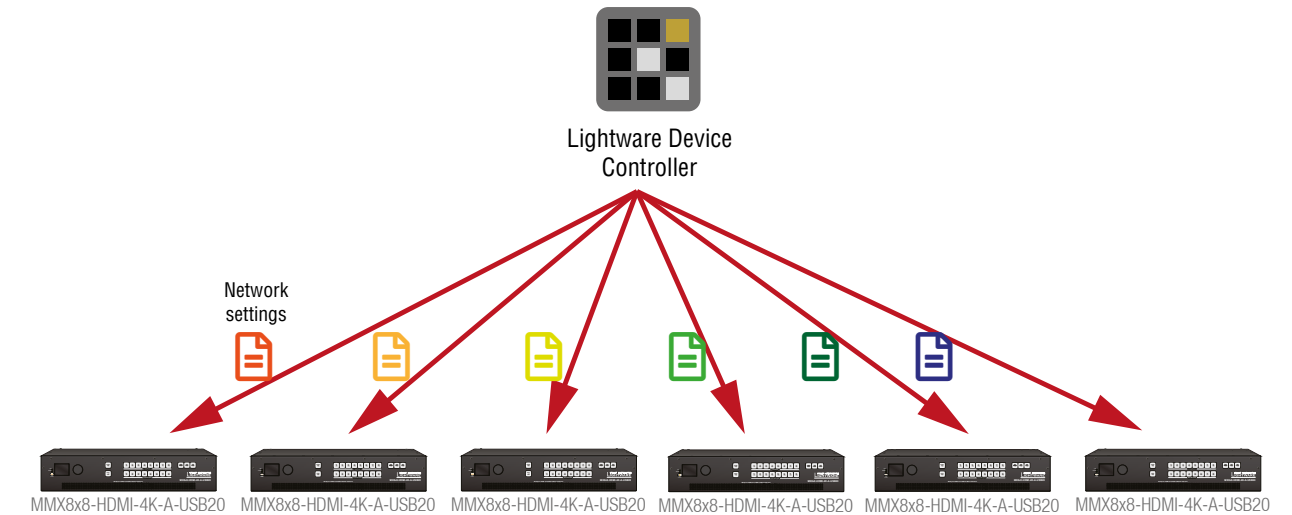

## 5.6. Infra Interface

### Summary of Infra Ports

	2-pole Phoenix		TRS (3.5mm Jack)	
	Nr.	Data transmission	Nr.	Data transmission
MMX8x8-HDMI-4K-A	2x	Tx	2x	Tx
MMX8x8-HDMI-4K-A-USB20	2x	Tx	2x	Tx

INFO: The 2-pole Phoenix connector can be both infra or serial output. For infra data transmission the destination TCP port numbers are **9001** and **9002**. No setting required for configuring the interface, it works automatically.

**ATTENTION!** The IR signal cannot be routed from an IR port to another IR port.

### Technical background

The Infrared signal transmission is similar to the serial data communication. The matrix contains a dedicated IR output where IR code sending is possible. The matrix can receive IR signals via the Control Ethernet port. The Infrared signal is in pronto hex format.

### Getting IR codes

Getting IR codes is possible from two sources:

- Download a code that belongs to your controlled device from a web database from the Internet. The downloaded codes are mostly in **little-endian format**.
- Learn an IR code (see the details below).

#### Learning an IR code

**Step 1.** Connect to a Lightware device that has an IR detector unit (e.g. UMX-TPS-140) with a terminal program.

**Step 2.** Push the proper button of the remote control to scan the IR codes in hex format.

**Step 3.** Remove all the non-hexadecimal characters (e.g. spaces, h characters etc.) from the code.

INFO: The pronto hex code that is learned by the Lightware device is **big-endian** format.

### Sending Big-endian format pronto hex codes

#### With an LW3 protocol command

**Step 1.** Connect to the **6107** port of the matrix.

**Step 2.** Use an LW3 protocol command to send the pronto hex code:

▶ `CALL /MEDIA/IR/D1:sendProntoHexBigEndian(<prontohex>)`

INFO: The maximum length of the code can be 765 characters (765 bytes). For more details about the accepted IR code formats, see the [Sending Pronto Hex Codes in Big-endian Format](#) section.

### Sending Little-endian format pronto hex codes

#### With the Lightware Device Controller software

**Step 1.** Connect to the **6107** port of the matrix and open the LDC software.

**Step 2.** Choose the desired IR output in the control menu, on the Infra tab.

**Step 3.** Copy the IR code into the **Send Pronto Hex** entry field and click on the **Send** button.

INFO: The maximum length of the code can be 765 characters (765 bytes). For more details about the accepted IR code formats, see the [Sending Pronto Hex Codes in Little-endian Format](#) section.

#### With an LW3 protocol command

**Step 1.** Connect to the **6107** port of the matrix.

**Step 2.** Use an LW3 protocol command to send the pronto hex code:

▶ `CALL /MEDIA/IR/D1:sendProntoHex(<prontohex>)`

INFO: The maximum length of the code can be 765 characters (765 bytes). For more details about the accepted IR code formats, see the [Sending Pronto Hex Codes in Little-endian Format](#) section.

#### With the Event Manager

**Step 1.** Connect to the **6107** port of the matrix.

**Step 2.** Create an event in Event manager. After setting any condition, set the action:

Category: **Infra**; Expression: **Send pronto hex**; Port: **D1-D6**; Pronto hex: **Insert the pronto hex code**.

INFO: The maximum length of the code can be 184 characters (184 bytes).

### Sending IR code in Command Injection mode

When the data transmission is enabled, the output port works in command injection mode. The IR data (in pronto hex format) is transferred between the LAN port and the IR port. Separate user-configurable TCP/IP port numbers are defined for IR output ports for this purpose, see the [Factory Default Settings](#) section. The settings are available in the LDC software, see the [SalvoHttp tab in the Control/Ethernet menu](#) section.

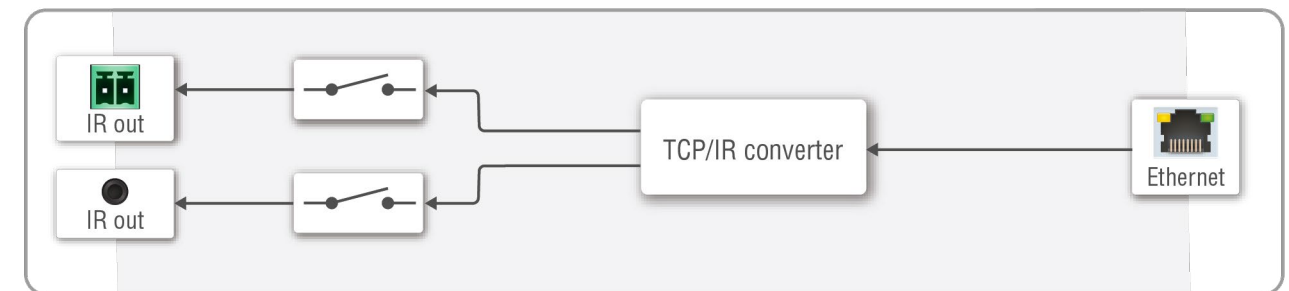

Port Diagram of IR Interface

**IR Interface - Example**

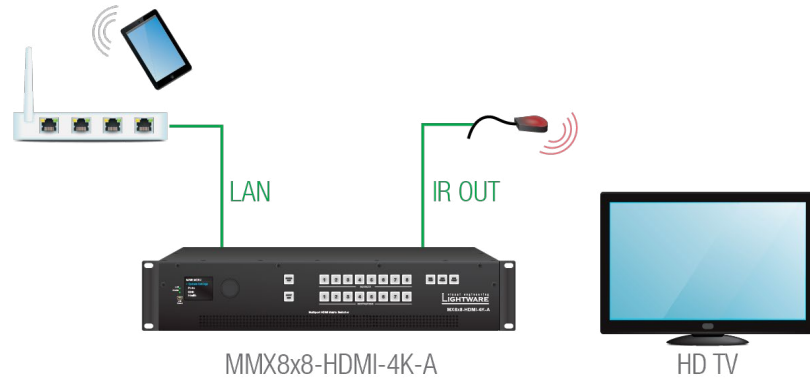

**The Concept**

An IR command ('Power on') can be sent from a smart phone with an IR - TCP/IP converter application over WI-FI. The TCP/IP message is forwarded to the matrix via the Control Ethernet port. The Matrix converts the TCP message into IR format and transmits the IR signal to the IR output port (e.g. 9001). The connected IR emitter sends the IR command ('Power on') to the TV.

**Settings**

**Matrix:** The Control Ethernet port (P2) can be enabled. Check the IR port number (default value is 9001). The port can be enabled (operation mode is always command injection).

**5.7. Serial Interface**

**5.7.1. Technical Background**

Serial data communication can be established via the local RS-232 port (Phoenix connector), TTL serial port (Phoenix connector) and over the TPS lines. The RS-232 ports – which are connected to the microcontroller – can be configured separately.

**INFO:** The 2-pole Phoenix connector can function as both infra and serial output depending on the sent message protocol. No setting required for configuring the interface, it works automatically.

**Summary of Serial Ports**

	Local						Remote		
	RS-232			TTL serial			Control Ethernet		
	Connector type	Nr. of connectors	Data transmission	Connector type	Nr. of connectors	Data transmission	Connector type	Nr. of connectors	Data transmission
<b>MMX8x8-HDMI-4K-A</b>	3-pole Phoenix	2x	Tx, Rx	2-pole Phoenix	2x	Tx	RJ45	1x	Tx, Rx
<b>MMX8x8-HDMI-4K-A-USB20</b>	3-pole Phoenix	2x	Tx, Rx	2-pole Phoenix	2x	Tx	RJ45	1x	Tx, Rx

**Summary of Serial Operation Modes**

The RS-232 port can be switched to **Control mode**, **Command Injection mode**, or can be **Disconnected**; see the table and the figure below.

	Disconnected	Control	Command Injection (CI)
<b>RS-232</b>	✓	✓	✓
<b>TTL serial</b>	-	-	✓



### 5.7.2. Serial Port Operation Modes

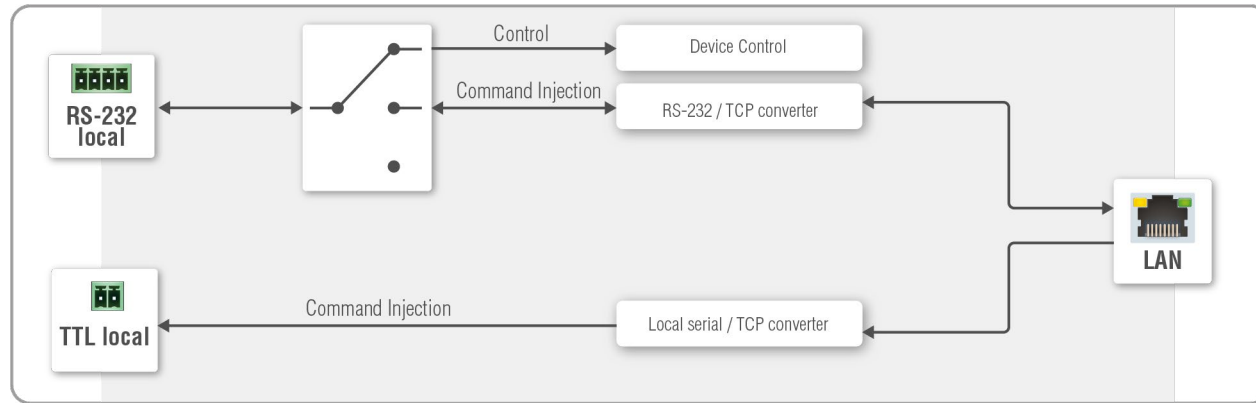

The block diagram of the Serial interface

#### 5.7.2.1. Disconnect mode

This mode is for controlling a third-party device from the Matrix. In this case, the Matrix does not receive RS-232 messages, but sends serial data from the CPU.



#### The concept

Powering on the HDTV via RS-232 message from the matrix.

#### Settings

The Matrix can send RS-232 commands over the local RS-232 ports (P1 or P2) to the HDTV. You can see the details about serial message sending in the [Sending Pronto Hex Codes in Little-endian Format](#) section.

#### 5.7.2.2. Control mode

The incoming data from the given port is processed and interpreted by the CPU. The mode allows to control the matrix directly. LW2 or LW3 protocol commands are accepted – depending on the current port setting.



#### Application example of control mode

#### The concept

The System controller sends commands to the Matrix that set the video and audio properties. The Matrix executes the commands and transmits the video signal to the sink.

#### Settings

The System controller can send LW2 or LW3 commands to the local RS-232 port (P1 or P2) of the Matrix. In control mode, the commands are processed in the device. This function makes it possible to set the crosspoint or a volume level etc.

#### 5.7.2.3. Command injection mode

In this mode, the matrix works as an RS-232–Ethernet bidirectional converter. The Ethernet packets are converted to RS-232 data and vice versa. Unique TCP/IP port numbers are defined for the serial ports for this purpose.

E.g. the default Command Injection port number of the local RS 232 port (P1) is 8001. If a command is coming from the LAN interface that is addressed to the port no. 8001, it will be transmitted to the Tx pin of the local RS-232 port. That also works in the opposite direction.

#### Application example of command injection mode

See the RS-232 settings in the [Factory Default Settings](#) section.



#### The concept

The System controller can send commands (input/output switching, control functions, etc.) to the matrix and is able to remote control the HDTV via RS-232.

### Settings

Matrix: The RS-232 interface of the Uart 1 port (P1) is in Command Injection (CI) mode. Set the further parameters (Baud rate, Data bits, etc.) in accordance with the specifications of the television.

All settings are available in the LDC software, see the [RS-232 Tab](#) section.

#### 5.7.2.4. TTL Serial

The 2-pole Phoenix connector can be both infra or serial output. For TTL data transmission the destination port numbers are **8003** and **8004**. No setting required for configuring the interface, it works automatically.

	TTL*	RS-232
Logic low level	0 .. 0.25V	3 V .. 15 V
Logic high level	4.75 .. 5.0V	-15 V .. -3 V

**Serial Output Voltage Levels (TTL and RS-232)**

\*Using a receiver with at least 1k impedance to any voltage between 0V and 5V to get the voltages.

#### 5.7.3. RS-232 Recognizer

**DIFFERENCE:** The feature mentioned below is available from FW package v1.1.0.

This tool is able to recognize and store the incoming RS-232 message until the previously defined string (delimiter) has arrived or the timeout has passed after the last data. The last incoming serial data is stored and it can trigger an action in Event Manager.

#### RS-232 Recognizer Example

When the **MMX8x8** has an active video signal, the switcher logs into the VC codec automatically.

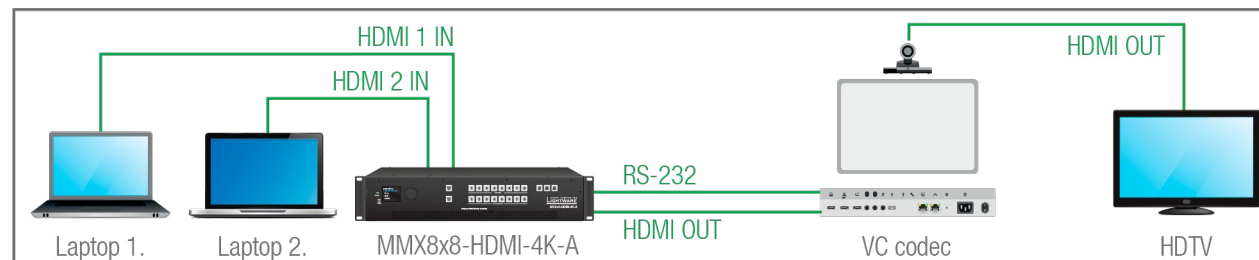

When the active signal is present on the output of the MMX8x8, it triggers a bi-directional communication with the VC codec via RS-232.

The communication between the matix switcher and the VC codec is the following:

- ▶ MMX8x8 (starts the communication on RS-232): **PING**
- ◀ VC codec (requests the login name): **Login name:**
- ▶ MMX8x8 (sends the login name): **Admin**
- ◀ VC codec (requests the password): **Password:**
- ▶ MMX8x8 (sends the password): **Admin**

First configure the recognizer for the serial communication, then set the events in the Event Manager.

The RS-232 recognizer settings can be arranged by LW3 protocol commands (see more information in the [RS-232 Message Recognizer](#) section).

Create the following events in the Event manager:

**E1.** When the signal is present on O1 port of the MMX8x8, it sends a message 'PING' on P1 port of RS-232 to the VC codec.

**E2.** Set a condition where **Login name:** is the recognized RS-232 message. Action is sending serial message ('Admin') on the P1 port to the VC codec.

**E3.** Set a condition where **Password:** is the recognized RS-232 message. Action is sending serial message ('Admin') on the P1 port to the VC codec.

For more information about setting the events, see the [Event Manager](#) section.

### 5.8. Batch Commands

**DIFFERENCE:** The features mentioned below are available from FW package v1.3.0.

These features can be used to process a group of pre-defined commands. The commands can be stored in the device as macros or you can save the commands in a plain text file and send them to the device by an HTTP message.

#### LW3 over HTTP (Command Salvo)

This feature allows the LW device to be controlled over HTTP. In this case a batch of commands is sent over HTTP to the Lightware device for processing. Save the LW3 commands into a file, post it to the <IP\_address>/protocol.lw3 file and the commands are processed immediately.

#### Running Macros

In this case the command sequences (macros) are stored in the device. You can create your custom macros in a file, upload it into the device and run at any time. The number of the macros depends on the device type, at most 50 macros can be saved in an MMX8x8 device. See more information about the feature in the [Macros](#) section.

## 5.9. GPIO Interface

**DIFFERENCE:** Only the MMX8x8-HDMI-4K-A-USB20 model has a GPIO connector.

The GPIO (General Purpose Input/Output) port is a multifunctional input/output interface to control the matrix or third-party devices and peripherals. You can establish connection between the controller/controllable device and the matrix by the 8-pole Phoenix connector. The direction of the six pins is configurable independently based on needs of the application.

### GPIO Options - Example

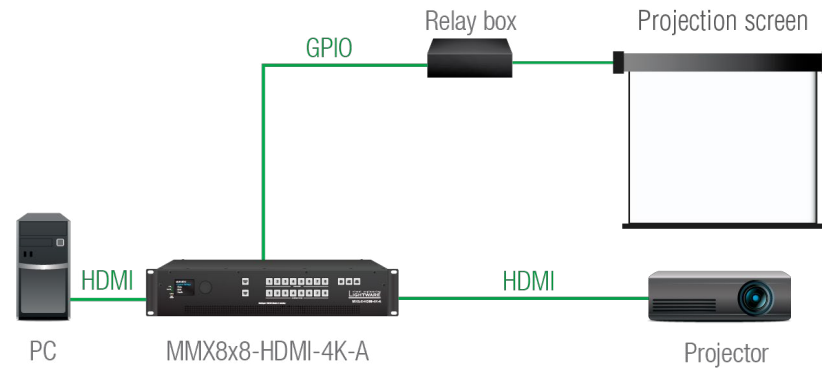

### The Concept

A projection screen is rolled down by a **Relay box** when a signal is received from the PC over the HDMI input. The relay box is controlled by the GPIO port.

### Settings

- Step 1.** Create an event in Event manager: when signal is present on Input 5 (I5), set the GPIO pins to low level to open the Relay box.
- Step 2.** Also create another event: when signal is not present on Input 5 (I5), set the GPIO pins to high level to close the Relay box.

When the PC starts to play the video presentation, the signal is received over the HDMI input, so the GPIO pins send a signal to the Relay box to open, which rolls down the projection screen.

When the presentation ends, the signal ceases on the HDMI input, so the GPIO pins send a signal to the Relay box to close, and the projection screen returns to its enclosure.

**ATTENTION!** Please always check the electrical parameters of the devices that you want to control. The maximum current of one GPIO pin is 30 mA, the maximum total current for the seven pins is 180 mA.

See the LDC settings for the GPIO port in the [USB Switch Tab](#) section. Also, see the details about the Event Manager settings in the [Macros](#) section.

## 5.10. Consumer Electronics Control (CEC) Interface

**DIFFERENCE:** The features mentioned below are available from firmware v1.1.0.

The CEC is a bi-directional communication defined in the HDMI standard. This feature is for remote controlling the source and sink devices in an AV system.

**INFO:** According to the standard, the CEC feature only works at HDMI ports.

The matrix switcher is able to send and receive CEC commands from the input ports towards the source, and from the output ports towards the sink. For more information about sending CEC messages, see the [CEC Tool](#) section.

CEC has a dedicated pin in the HDMI connector. DVI connector does not contain this pin, so the CEC transmission is unavailable when an HDMI-DVI connector or adapter is in the signal route.

### CEC Application Example

When active signal is detected on HDMI in, the switcher automatically sends a CEC message to the HDTV to wake up.

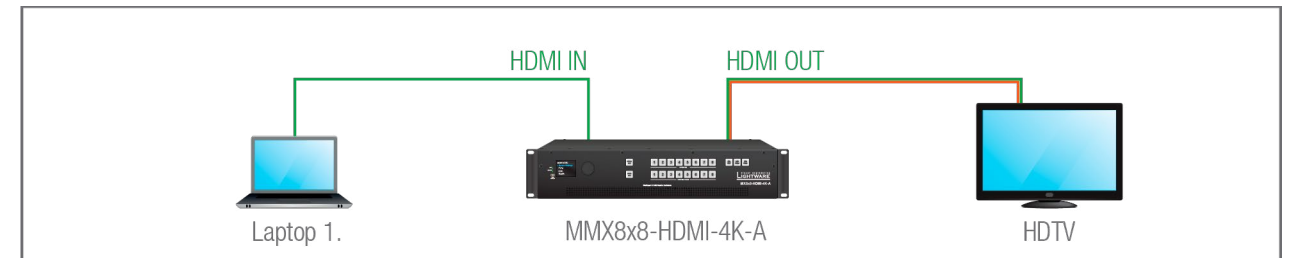

Create an event in the Event manager:

- Set a Condition: signal is present on the input port (I1),
- Set an Action: send CEC command 'Image view' on the output port (O1).

See the details about the Event Manager settings in the [Event Manager](#) section.

## 5.11. The Event Manager Feature

The Event Manager feature means that the device can sense changes on its ports and is able to react according to the pre-defined settings. Lightware Device Controller contains a user-friendly software tool and allows creating Events by defining a Condition and an Action.

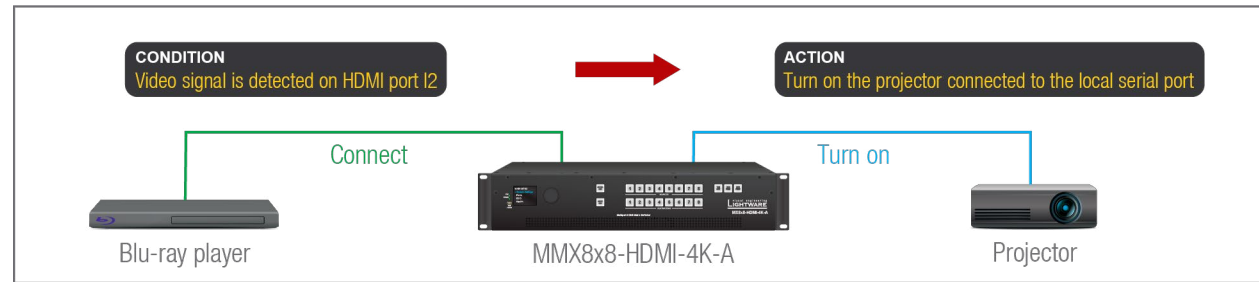

**Event Manager Example**

See more information about the settings in the [Event Manager](#) section in LDC.

### Event Manager +

**DIFFERENCE:** The features mentioned below are available from FW package v1.3.0.

#### The AND Operator

The practical experience has shown that there is a need to examine several conditions as follows: one condition exists, and the other is a change that occurs. For example, in a meeting room we have the following situation:

- Signal is present on an input port,
- A GPIO pin state becomes 'low' (by an external device).

If the two **Conditions** are present at the same time, the **Action** is launched. Just create the two **Conditions** into separate Events, then create a third Event, select the two **Conditions** and define the **Action**. Up to four Conditions can be linked together.

See the [Create or Modify an Event](#) section for the settings in LDC.

#### Event Manager Variables

A brand new area is opened by implementing the variables. You can create custom variables in number or text format, which can be used in the Event Manager. The variables can have the following properties/methods:

- Numeric (integer) type with min/max value setting, or string-type (determined automatically)
- Increment/step the numeric value,
- Value-dependent case operations,
- Reading and storing the value of an LW3 property into a string or a numeric variable.

The defined variables are stored in a non-volatile memory and the value is kept in case of a reboot. The new opportunities allow creating a monitoring/controlling system without connecting an additional control processor.

See the [Special Tools and Accessories](#) section for the settings in LDC.

### Condition Trigger

This improvement in the Event Manager works as if a condition is detected. When a complex control system is built, a Condition may trigger numerous Actions. A typical example is when a system is powered on and the 'ready-to-use' state has to be loaded. In this case, there could be many actions that are based on the same condition. In order to reduce the number of the commands, you can trigger one 'key' condition, which could start the whole process.

See the [Special Tools and Accessories](#) section for the settings in LDC.

## 5.12. Basic IT Security

These entry-level network security improvements help prevent unauthorized access to the Lightware device:

- **Cleartext login**
- **IP Port Block**
- **MAC Filtering**

The **Cleartext Login** tool allows setting a password for login, thus the device will not accept any command coming from an interface (RS-232, Ethernet, etc...), only the device type and the serial number can be queried without login. You can set all affected TCP/IP ports individually to enabled or disabled.

The **IP Port Block** feature is an additional protection for the Cleartext login. There are TCP/IP ports in Lightware devices that are not protected by the login, so you can disable them if necessary. Example: due to the working method of the LW2 communication, the Cleartext login does not provide protection when an LW2 command is sent to the device, that is why the TCP port no.10001 shall be blocked manually.

Another level of security is the **MAC Filtering** tool. You can create an 'allowlist' of network devices based on the MAC address that are allowed:

- Controlling the device (Send option), or
- Querying parameters (Receive option) to/from the Lightware device.

The table below shows the protection levels of these features.

IP Port	Function	MAC Filter	Cleartext Login	IP Port Block
80	HTTP Post&Get	✓	-	✓
81	LW3 control (miniweb)	✓	✓	-
6107	LW3 protocol	✓	✓	-
800x	Command injection (RS-232)	✓	-	✓
900x	Command injection (IR)	✓	-	✓
10001	LW2 protocol	✓	-	✓

**ATTENTION!** Be careful when combining these functions; improper settings may cause malfunction.

Most of these features are available in LDC, see the [Network](#) section.

## 5.13. USB Interface

### 5.13.1. USB Control

All models can be controlled over the front panel USB port (mini B-type connector). This interface supports LW3 protocol. The interface can be used to establish a connection to Lightware Device Controller software.

### 5.13.2. USB 2.0 Interface

**DIFFERENCE:** MMX8x8-HDMI-4K-A-USB20 matrix can transmit the USB 2.0 data via USB type-A and USB type-B connectors. In the other models, USB control operates locally, USB data is not transmitted.

**INFO:** The first USB-A port can send 1000mA output power and the capacity of the other three are 500mA.

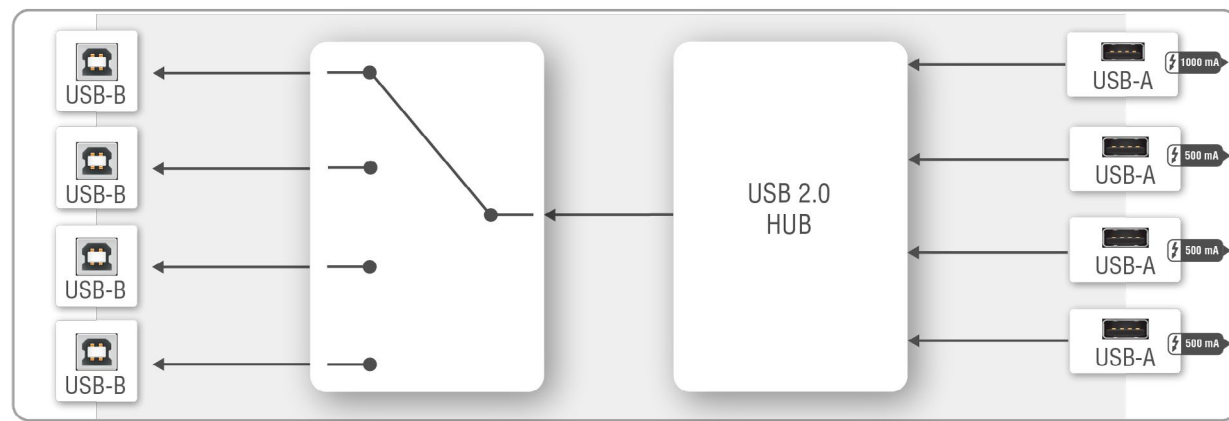

#### Host detection

One host is available of the four at the same time. MMX8x8-HDMI-4K-A-USB20 gives a feedback about the connected hosts. When the 5V is detected on USB Vbus, the **Host5VSensePC** property becomes true (this can be a trigger or condition in the Event Manager).

#### Enable the Power Switch Delay

After switching between the hosts, some connected USB devices need to be reset to operate properly. Enabling the power switch delay function allows users to reset the connected USB device within the software without the need to physically unplug/re-plug a device. It turns off the 5V power of all the devices for 2s, and this forces them to restart.

#### Device5VEnable

This function allows sending 5V power to the device. Most USB devices are powered by this 5V, so disabling and enabling this property is equal to unplugging the USB connector and plugging it back in.

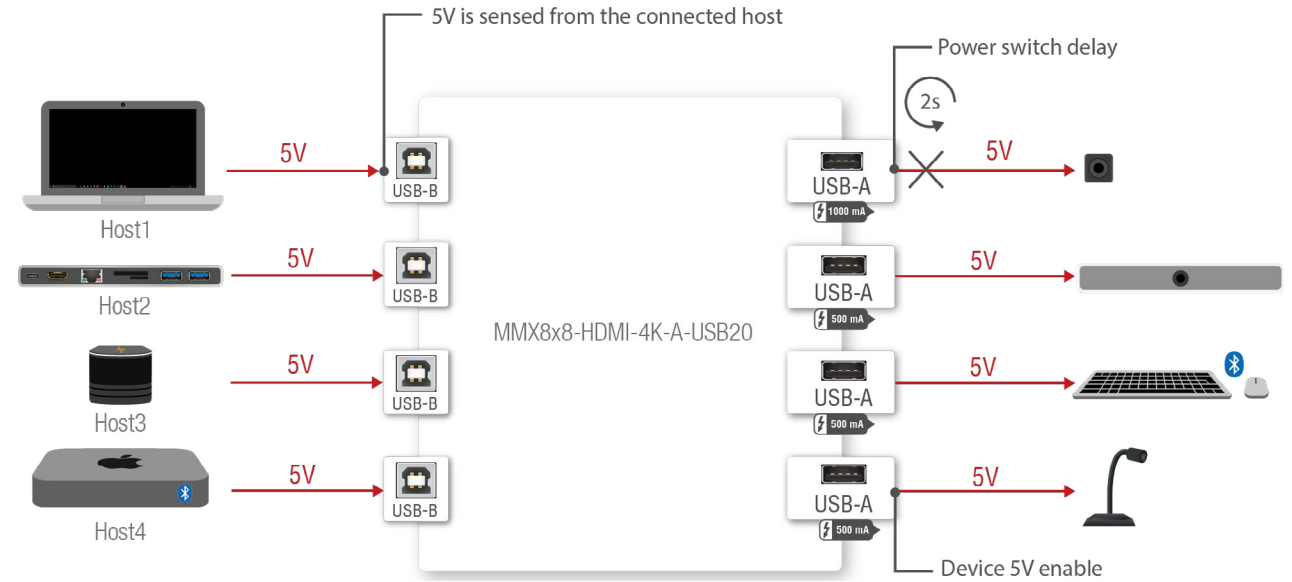

**USB features in MMX8x8-HDMI-4K-A-USB20**

### Application of USB - Example

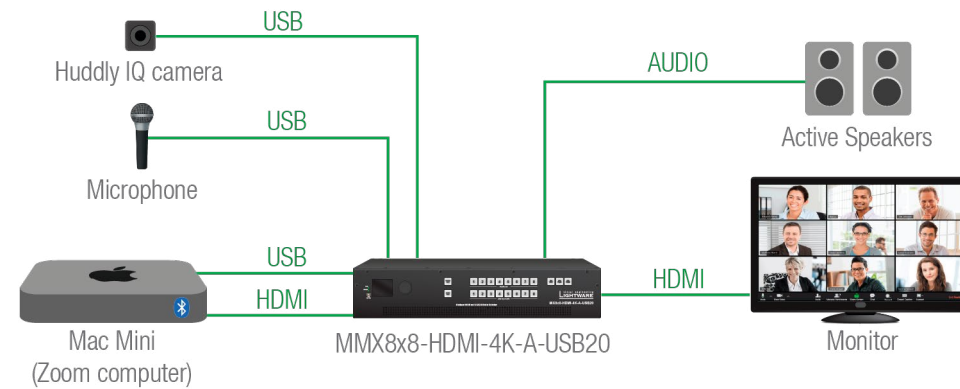

### The Concept

The voice and the picture of the webcam comes over USB-A ports (Device1 and Device2 ) to the matrix and is transmitted towards the Mac Mini via USB-B port (PC1). The matrix is connected to the Mac Mini with a HDMI cable, too (I1). The Mac Mini sends the video signal of the webcam and the audio signal of the microphone via HDMI. The matrix de-embeds the audio and forwards it to the Active speakers. The video is transmitted to the monitor via HDMI (O2).

### Settings

- Step 1.** In the Control menu, USB switch tab, choose the PC1 from the drop-down menu of the USB Host.
- Step 2.** Take care that the sending 5V possibility of the connected USB devices is enabled (Device1 and Device2).
- Step 3.** The video crosspoint is switched to I1-O2.
- Step 4.** In the O2 video parameters window, set the De-embed to aux audio option from the drop-down menu of the Audio mode.

# 6

## Software Control – Lightware Device Controller

The matrix can be controlled by a computer through the LAN or USB ports using Lightware Device Controller (LDC). The software can be installed on a Windows PC or macOS. The application can be downloaded from [www.lightware.com](http://www.lightware.com). The Windows and the Mac versions have the same look and functionality.

- ▶ INSTALL AND UPGRADE
- ▶ RUNNING THE LDC
- ▶ DEVICE DISCOVERY WINDOW
- ▶ BULK DEVICE MANAGEMENT
- ▶ CROSSPOINT MENU
- ▶ PORT PROPERTIES WINDOWS
- ▶ CEC TOOL
- ▶ DIAGNOSTIC TOOLS
- ▶ PRESETS TAB
- ▶ EDID MENU
- ▶ CONTROL MENU
- ▶ EVENT MANAGER
- ▶ SETTINGS MENU
- ▶ CONFIGURATION CLONING (BACKUP TAB)
- ▶ THE BUILT-IN MINIWEB
- ▶ ADVANCED VIEW

## 6.1. Install and Upgrade

### Installation for Windows OS

**ATTENTION!** The minimum display resolution shall be 1280x720.

**Step 1.** Run the installer. If the User Account Control drops a pop-up message, click Yes.

**Step 2.** During the installation you will be prompted to select the type of the installation: **normal** and the **snapshot** install:

Normal install	Snapshot install
Available for Windows and macOS	Available for Windows
The installer can update only this instance	Cannot be updated
Only one updateable instance can exist for all users	Different versions can be installed for all users

*Comparison of the Installation Types*

**ATTENTION!** Using the Normal install as the default value is highly recommended.

### Installation for macOS

**INFO:** After the installation, the Windows and the Mac applications have the same look and functionality. This type of the installer is equal to the Normal install in the case of Windows and results in an updateable version with the same attributes.

Mount the DMG file by double clicking on it, and drag the LDC icon over the Applications icon to copy the program into the Applications folder. If you want to copy the LDC into another location, just drag the icon over the desired folder.

**ATTENTION!** Please check the firewall settings on the macOS device. LDC needs to be added to the exceptions of the blocked software for the proper operation.

### The Upgrading of the LDC

**Step 1.** Run the application.

The **Device Discovery** window appears automatically, and the program checks the available updates on Lightware's website and opens the update window if LDC updates are found. The current and the update version number can be seen at the top of the window and they are shown in this window even with the snapshot install. The **Update** window can also be opened by clicking on the **About icon** and the **Update** button.

**Step 2.** Set the desired update setting in the **Options** section.

- If you do not want to check for the updates automatically, uncheck **the circle** that contains the green tick.
- If you want to postpone the update, a reminder can be set with different delays from the **drop down list**.
- If the proxy settings traverse the update process, set the proper values, then click on the **OK** button.

**Step 3.** Click on the **Download update** button to start the updating.

The updates can be checked manually by clicking on the **Check now** button.

## 6.2. Running the LDC

The common way to start the software is to double-click on the LDC icon. But the LDC can be run by command line parameters as follows:

### Connecting to a Device with Static IP Address

The LDC is connected to a device with the indicated static IP address directly; the Device Discovery window is not displayed. When the port number is not set, the default port is used: 10001 (LW2 protocol). For LW3, devices use the 6107 port number.

**Format:** `LightwareDeviceController -i <IP_address>:<port>`

**Example:** `LightwareDeviceController -i 192.168.0.20:6107`

### Connecting to a Device via a Serial Port

The LDC is connected to a device with the indicated COM port directly; the Device Discovery window is not displayed. If no Baud rate is set, the application will detect it automatically.

**Format:** `LightwareDeviceController -c <COM_port>:<Baud>`

**Example:** `LightwareDeviceController -c COM1:57600`

### Adjusting the Zoom

The window can be zoomed to a specific value to fit to the resolution of the desktop (higher/lower). '1' is the default value (100%).

**Format:** `LightwareDeviceController -z <magnifying_value>`

**Example:** `LightwareDeviceController -z 1.2`

**ATTENTION!** The last set value is stored and applied when LDC is started without a parameter.

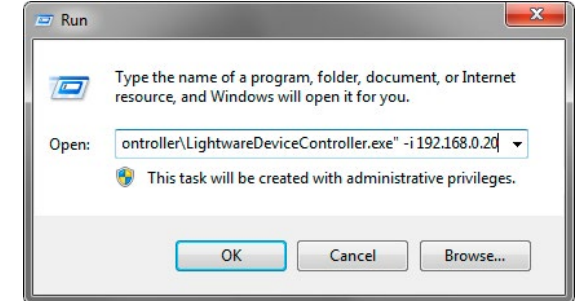



### 6.3. Device Discovery Window

There are three tabs for the different types of interfaces, select the Ethernet, Serial devices or USB tab.

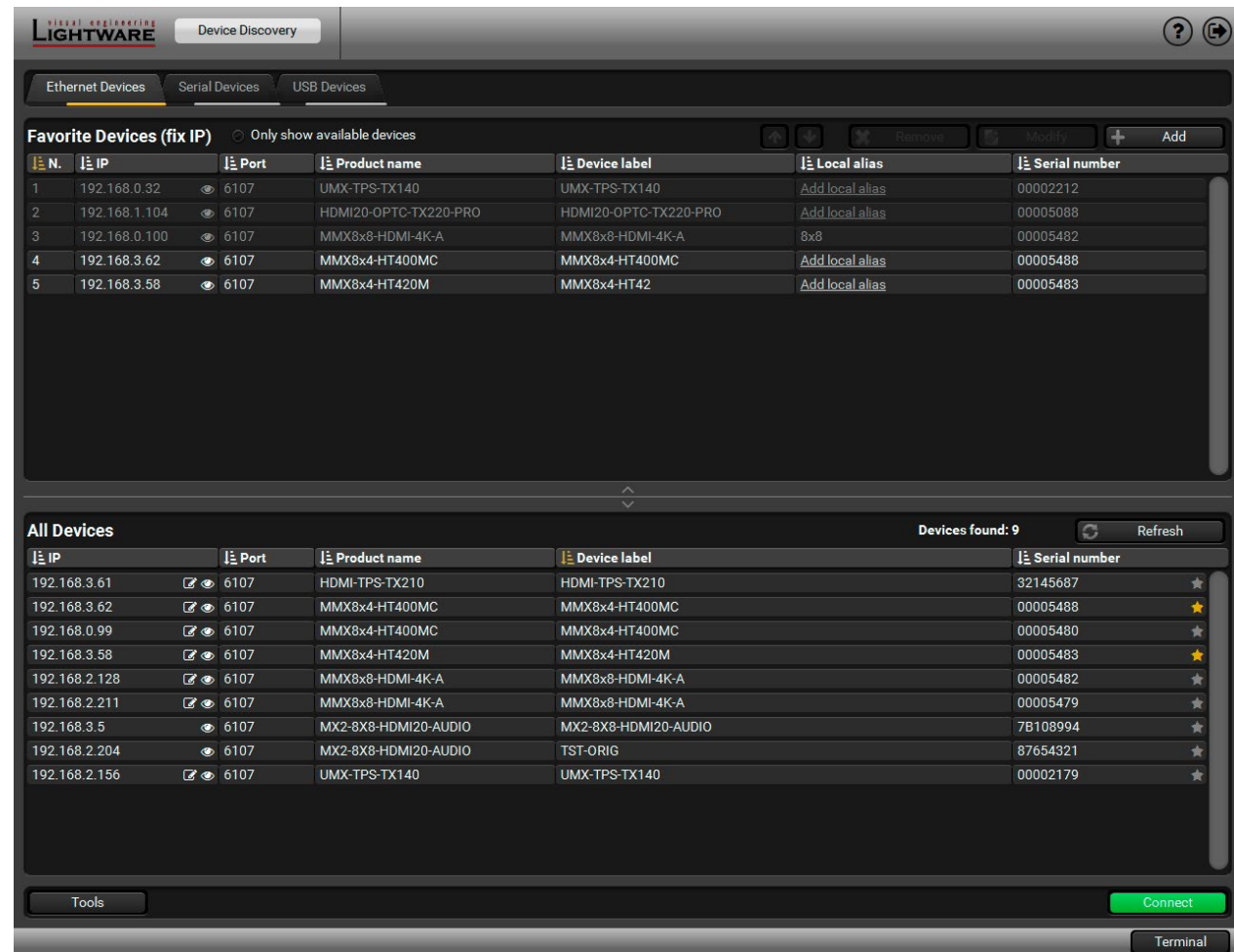

Device Discovery Window

#### Establishing the Connection

Select the unit from the discovered Ethernet devices; double click on the device, or select it and click on the green **Connect** button.

#### Identifying the Device

Clicking on the icon results in a **Device identified!** message on the LCD screen. The feature helps identify the device itself in the rack shelf

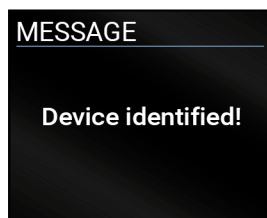

The Ethernet tab consists of two lists:

- Favorite Devices**
  - You can add any Lightware device that is connected via Ethernet, no need to browse all available devices. Devices can be added in two ways:
    - by pressing the **Add** button and entering the desired device's IP address or the hostname, if it is supported. The hostname allows setting a unique name to identify the device in the network. If the host name is saved in this window, and the IP address is changing, the device will still be available and connectible, or
    - by marking the desired device with the ★ symbol in the **All Devices** list.
  - All Devices:** The Lightware devices are listed that are available in the connected network.

**ATTENTION!** The host name connection-feature does not work when the target device is accessed over VPN.

See more information about the host name property in the [Setting the Host Name](#) section.

#### Further Tools

The **Tools** menu contains the following options:

- Log Viewer:** The tool can be used for reviewing log files that have been saved previously.
- Create EDID:** This tool opens the Easy EDID Creator wizard, which can be used for creating unique EDIDs in a few simple steps. Functionality is the same as the Easy EDID Creator, for the detailed information, see the [Creating an EDID](#) section.
- Demo Mode:** This is a virtual MX-FR17 matrix router with full functionality built into the LDC. Functions and options are the same as a real MX-FR17 device.
- Bulk Management:** This tool allows changing the network settings of several devices at once. See the details in the next section.

The **Terminal** window is also available by pressing its button on the bottom.

#### IP Address Configuration

The IP settings of a device can be changed without establishing the connection to the LDC. If the feature is supported by the device, an icon is displayed next to the IP address:

Press the icon to open the IP configuration window and set the necessary parameters, then press the **Apply** button (or **Cancel** to discard and exit).

#dhcp ipaddress

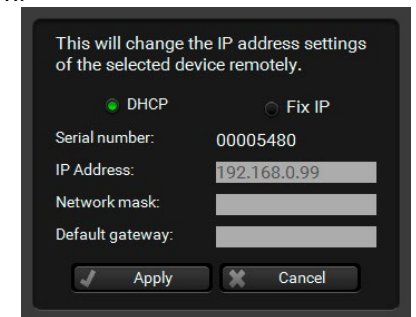
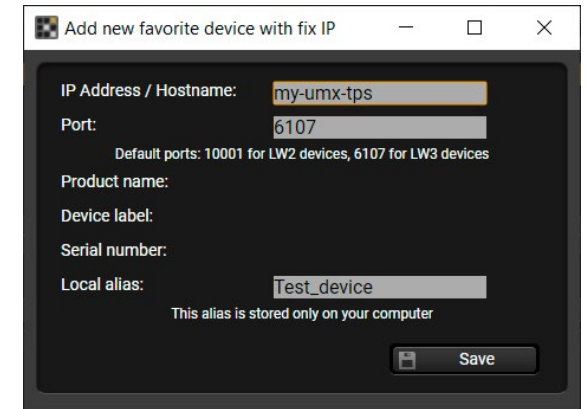

### 6.4. Bulk Device Management

It is possible to configure several devices at once with the Bulk Device Management tool. This feature can be accessed by clicking on the Tools button in the bottom left corner of the Device Discovery window and choosing the Bulk Management option.

#new

**DIFFERENCE:** This function is available from the firmware version v2.6.0b6 of the LDC and v1.4.0b3 of the MMX8x8-HDMI series devices.

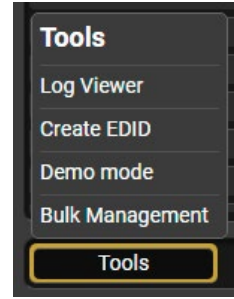

#### 6.4.1. Network Settings

It is possible to set the network settings of several devices at once by using a .csv file that contains the list of the devices that we need to configure, then uploading it into the LDC.

Please note that if the data in the file is missing or incorrect, then the discovery of the affected device will fail and an 'Invalid data' message will be displayed in the State column. In case of an IP or MAC address conflict, the message is 'Duplicated'.

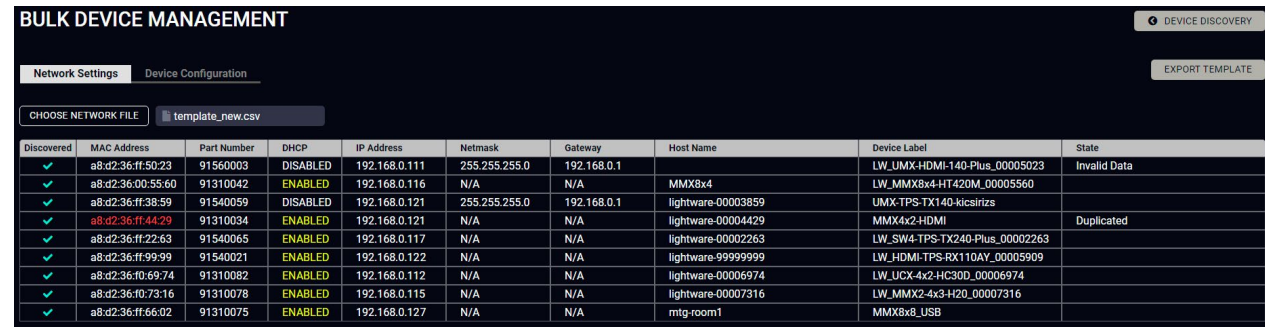

Discovered	MAC Address	Part Number	DHCP	IP Address	Netmask	Gateway	Host Name	Device Label	State
✓	a8:d2:36:ff:50:23	91560003	DISABLED	192.168.0.111	255.255.255.0	192.168.0.1		LW_UMX-HDMI-140-Plus_00005023	Invalid Data
✓	a8:d2:36:00:55:60	91310042	ENABLED	192.168.0.116	N/A	N/A	MMX8x4	LW_MMX8x4-HT420M_00005560	All Done
✓	a8:d2:36:ff:38:59	91540059	DISABLED	192.168.0.121	255.255.255.0	192.168.0.1	lightware-00003859	UMX-TPS-TX140-kicsirizs	Partly Done
✓	a8:d2:36:ff:44:29	91310034	ENABLED	192.168.0.121	N/A	N/A	lightware-00004429	MMX4x2-HDMI	Duplicated
✓	a8:d2:36:ff:22:63	91540065	ENABLED	192.168.0.117	N/A	N/A	lightware-00002263	LW_SW4-TPS-TX240-Plus_00002263	All Done
✓	a8:d2:36:ff:99:99	91540021	ENABLED	192.168.0.122	N/A	N/A	lightware-99999999	LW_HDMI-TPS-RX110AY_00005909	All Done
✓	a8:d2:36:f0:69:74	91310082	ENABLED	192.168.0.112	N/A	N/A	lightware-00006974	LW_UCX-4x2-HC30D_00006974	All Done
✓	a8:d2:36:f0:73:16	91310078	ENABLED	192.168.0.115	N/A	N/A	lightware-00007316	LW_MMX2-4x3-H20_00007316	All Done
✓	a8:d2:36:ff:66:02	91310075	ENABLED	192.168.0.127	N/A	N/A	mtg-room1	MMX8x8_USB	All Done

Changing the network settings can be done in a few easy steps:

- Step 1.** First alter the settings you need to change in the .csv file that contains the devices. You can use a template file accessible via the **Export template** button and saving the file to your computer, then filling it out with the parameters of the devices. The file contains the MAC address, Partnumber DHCP status, IP address, Netmask, Gateway, Hostname and Device label of each device.
- Step 2.** Upload the .csv file into the LDC by pressing the **Choose network file** button and browsing the file in the pop-up window. This will result in a list of the devices appearing on the screen.
- Step 3.** Finally, press the **Apply settings** button to execute the changes. This might take up to a minute to finish.

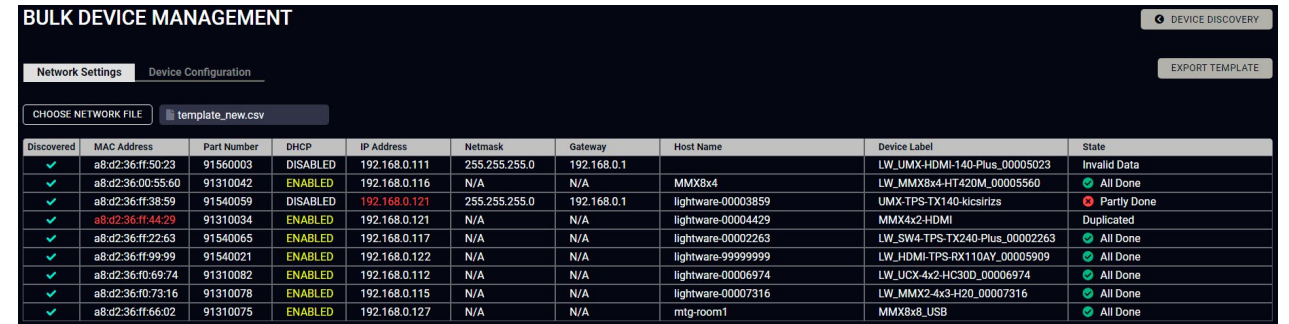

Message	DHCP enabled	DHCP disabled	Device discovered
✓ All Done	Successful procedure		✓
✗ Partly Done	Failure setting the Host name and/or the Device label		✗
Unavailable device	Host name <b>and</b> Device label missing	IP address, Network, <b>and/or</b> Gateway missing	✗
Failed	Host name <b>and</b> Device label incorrect	IP address, Network <b>and</b> Gateway incorrect	✓
IP mismatch	-	Host name <b>and</b> Device label incorrect	✗

**ATTENTION!** The 'Failed' and 'IP mismatch' status indicators are not common, they appear when the multicast and/or the port used for LMDMP connection is disabled, or if the firmware version of the device is below the recommended (see the pop-up window when opening the Bulk Management or the beginning of this chapter).

## 6.5. Crosspoint Menu

When LDC finds the device, it determines the product type and the LDC starts with the default page, showing the Crosspoint menu. *#crosspoint #switch*

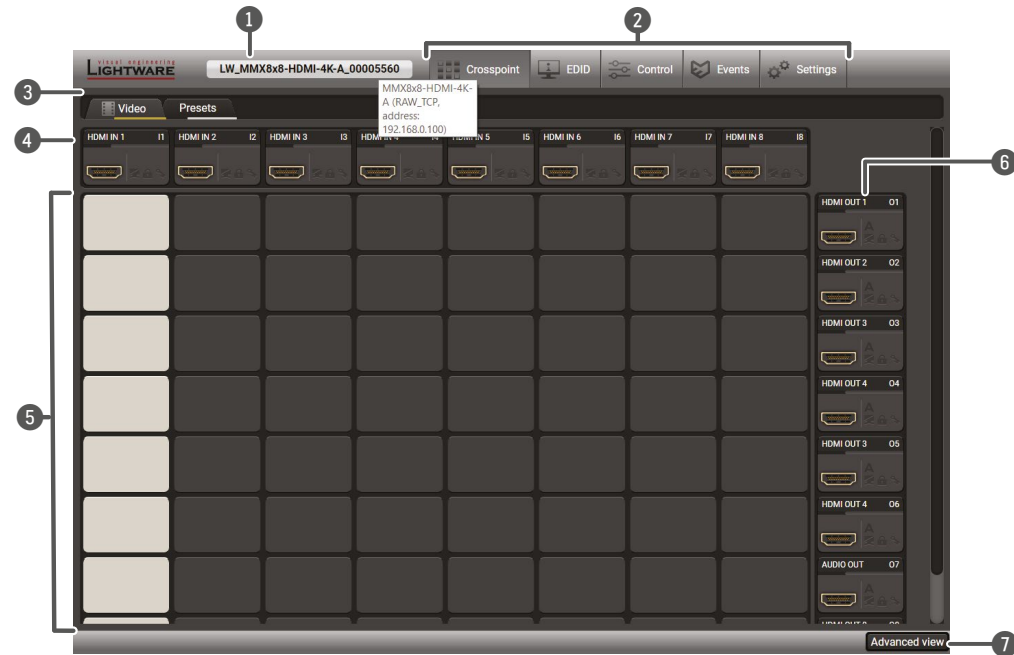

- 1 Device Label** The **Device Discovery** window can be opened by clicking on this ribbon. The Device Label is displayed, which is not the same as the Product Name. The Product name and the IP address are displayed in a hint box when the mouse cursor is above the label. *#devicelabel*
- 2 Main Menu** The available menu items are displayed. The active one is highlighted with a dark grey background color.
- 3 Tab Selector Ribbon** Select the desired **Port Properties Windows**, **Presets Tab**, or **Presets Tab**.
- 4 Input Ports** Each number represents an input port. Click on the port to display the **HDMI Input Port Properties** window.
- 5 Connections** **Grey** square means the port is available, but there is no connection. **White** square means there is a connection between the input and the output port. *#crosspoint #switch*
- 6 Output Ports** Each number represents an output port. Click on the port to display the **HDMI Output Port Properties** window.
- 7 Advanced View** Displaying the **Advanced View** page, showing the Terminal window and the LW3 protocol tree. *#advancedview #terminal*

### 6.5.1. Crosspoint Operations

#### Switching

To make a connection, click on the desired square. If there is no connection between the desired input and output (the square is dark grey), the mouse pointer becomes a hand (link pointer) before clicking. If the output port is not locked, the connection is made, the square becomes white and the cursor changes back to a pointer. *#crosspoint #switch*

For example, Input 8 is not connected to Output 1 as shown on the first picture. If the connection is established, the square becomes white.



#### Port Tiles

The colors of the port tiles and the displayed icons represent different states and information:

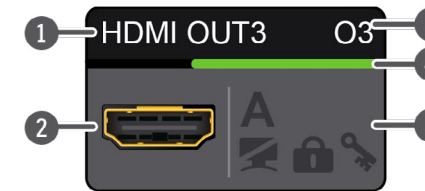

- 1 Port name
- 2 Port symbol
- 3 Port number
- 4 Signal present indicator
- green:** present
- grey:** not present
- 5 State indicators

#### State Indicators

Icon	Icon is grey	Icon is black
	The port is unmuted	The port is muted
	The port is unlocked	The port is locked
	Signal is <b>not</b> encrypted with HDCP	Signal is encrypted with HDCP
Icon	Icon is grey	Icon is green
<b>A</b>	Autoselect setting is disabled	Autoselect setting is enabled

## 6.6. Port Properties Windows

### 6.6.1. HDMI Input Port Properties

Click on a port to display its properties; Signal status information and the most important parameters are displayed.

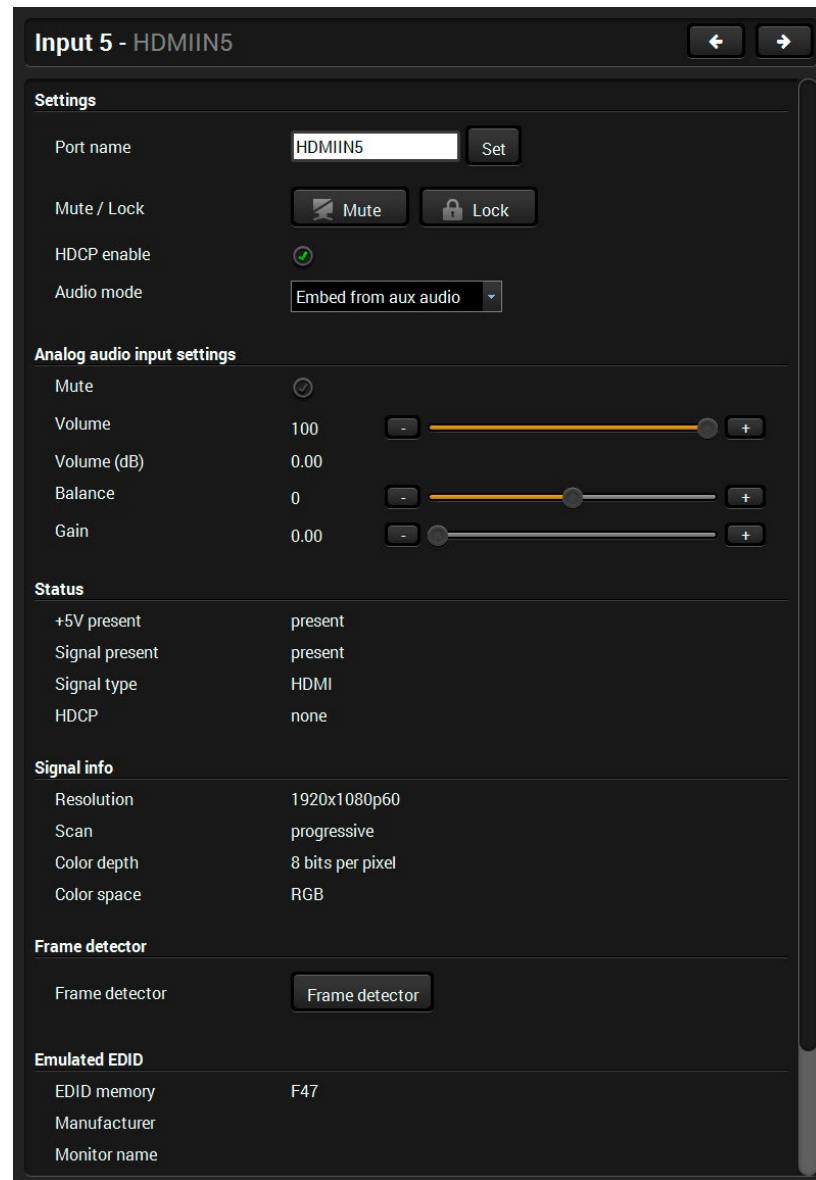

**HDMI Input Port Properties Window in MMX8x8-HDMI-4K-A model**

#analogaudio #balance #volume #hdcp #lock #unlock #mute #unmute #portstatus #diagnostic  
#framedetector

#### Available Settings

- Port name
- Mute/unmute the port;
- Lock/unlock the port;
- HDCP setting (enable / disable);
- Audio mode (HDMI audio passthrough / Embed from aux audio / Deembedded to aux audio)

#### Analog Audio Input Settings

The displayed configurable settings depend on the chosen audio mode.

INFO: Audio mode is available at the **I2, I4, I6, I8, O2, O4** ports of the **MMX8x8-HDMI-4K-A** model.

Depending on the chosen audio mode, the following parameters can be set:

##### HDMI audio passthrough

The embedded audio of the HDMI signal will be transmitted without any modification.

##### Embed from aux audio

Audio embedder is able to add (or replace) an audio stream to an HDMI video.

- Mute/unmute
- Volume: from 100 to 0%, in step 1% (0 dB to -48.18dB, default is 0 dB)
- Balance from L 100 to R 100, in step 1 (default is 0 = center)
- Gain from 0.00 to 24.00, in step 1.00 (default is 0.00)

##### Deembedded to aux audio

Audio de-embedder is able to separate the HDMI video and audio.

- Mute/unmute
- Volume: from 100 to 0%, in step 1% (0 dB to -95.62dB, default is 0 dB)
- Balance from -100 to 100, in step 1 (default is 0 = center)

#### Status and Signal Info

It gives a feedback about the current parameters the of the video signal:

- +5V Present / Signal present / Signal type / HDCP
- Resolution / Scan / Color depth / Color space

#### Frame Detector

See more details about the Frame Detector in the [Frame Detector](#) section.

#### Emulated EDID

Displays the basic information about the emulated EDID.

#### Other

Reloading [Factory Default Settings](#) for the selected port.

## 6.6.2. HDMI Output Port Properties

**Output 2 - HDMI OUT 2**

**Settings**

Port name: HDMI OUT 2 [Set]

Mute / Lock: [Mute] [Lock]

Autoselect: Settings [Disabled] Mode [Priority detect]

Priorities: Hint: 0 - highest priority, 7 - lowest priority. I1: 0, I2: 1, I3: 2, I4: 3, I5: 4, I6: 5, I7: 6, I8: 7. [Set priorities]

Signal type: Auto

HDCP mode: Auto

PWR5V mode: Always on

Audio mode: HDMI audio passthrough

**No sync screen**

Test pattern: Mode [Off], Clock source [480p], Pattern [Bar] [Test pattern]

**Status**

Monitor present	none
Signal present	present
Signal type	DVI
HDCP	none
Hotplug detect	none

**HDMI Output Port Properties Window**

### Available Settings

- **Mute/unmute** the port;
- **Lock/unlock** the port;
- **Autoselect settings** (see below)
- **Signal type** (Auto / DVI / HDMI);
- **HDCP mode** (Auto / Always): The matrix forces the source to send the signal without encryption if the content allows when **Auto mode** is selected.
- **PWR5V mode** (Auto / Always on / Always off): The setting lets the source and the sink devices be connected – independently from the transmitted signal;
- Send and receive Consumer Electronics Control (CEC) commands by the [CEC Tool](#).
- **No sync screen**: Test pattern configuration settings; see more details in the [Test Pattern Generator - No Sync Screen](#) section.
- Audio mode (only in the **O2** and **O4** ports of the MMX8x8-HDMI-4K-A model);
- Reloading the [Factory Default Settings](#) for the selected port.

### Autoselect Settings

Pay attention to the following settings for the proper operation of the Autoselect function:

- Be sure that no input is set to the same priority number;
- Be sure that all priority values are filled in (no empty space);
- Be sure that all inputs are enabled with the green checkbox on the right side;
- Always click on the **Set priorities** button after the changes to launch the new settings;
- Set the Autoselect settings to **Enabled**.

(See more details about the feature in [The Autoselect Feature](#) section.)

### Analog audio settings *#analogaudio #balance #volume*

The settings depend on the selected audio mode; see more details in the [Analog Audio Input Settings](#) section.

*#hdcp #lock #unlock #mute #unmute #portstatus*

*#framedetector #autoselect #nosyncscreen #testpattern*

## 6.7. CEC Tool

**INFO:** According to the standard, the CEC feature only works at HDMI ports.

The MMX8x8-HDMI series matrix switchers are able to send and receive Consumer Electronics Control (CEC) commands. This feature is for remote control of the source or sink device. CEC is a bi-directional communication via HDMI cable, in this case between the output port of the matrix switcher and the sink.

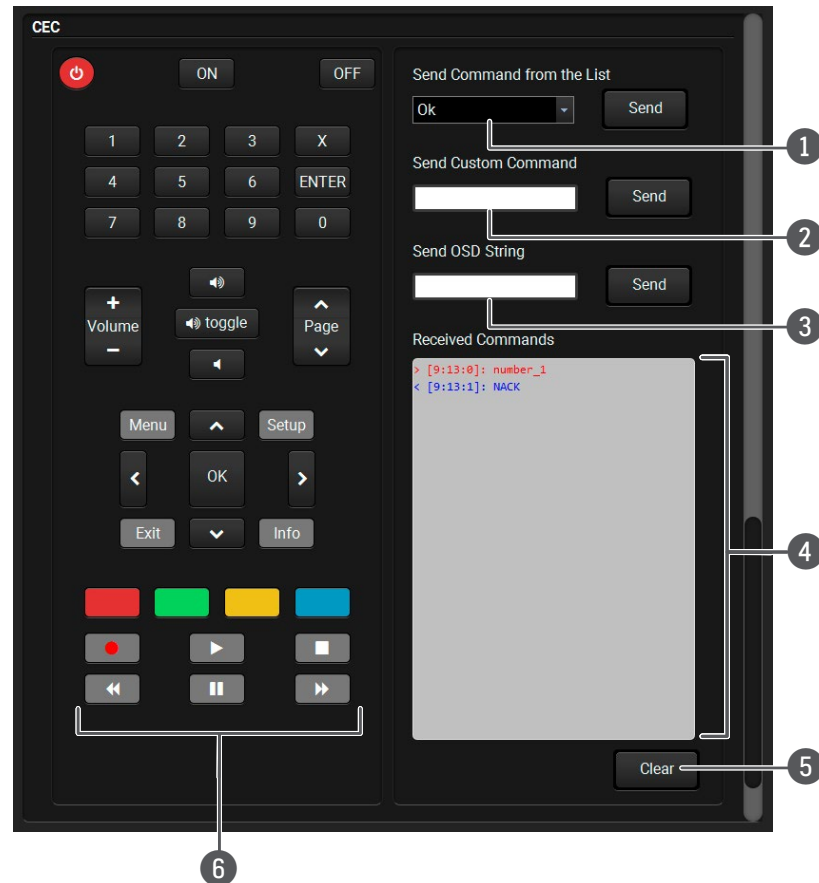

**Layout of CEC panel in Lightware Device Controller**

#cec

- 1 Drop-down command list** This list contains the basic CEC commands, most of them are displayed on the graphical interface, too (on the left side). Click on the **Send** button to send the command.
- 2 Custom command textbox** The text field is for sending hexadecimal commands to the source. The maximum length of the message could be 30 characters (15 bytes). Click on the **Send** button to send the command.
- 3 OSD string textbox** A max. 14-character-long text can be shown on the sink device. The send OSD (On-screen display) command textbox is the input field of the string. Alphanumeric characters, glyphs and space are accepted. Click on the **Send** button to execute the command.
- 4 Received Command box** Displays all sent CEC commands (in red) and received answers (in blue) with a timestamp.  
**Legend of the received message:**  
**< [10:33:17] ACK**  
 Answer for the acknowledged command.  
**< [10:35:01] NACK**  
 Answer for the not acknowledged command.  
**< [10:33:17] IN PROGRESS**  
 The command is in progress at the moment.  
**< [10:33:17] FAILED**  
 Answer for other failure.  
**< [10:35:40] feature\_abort\_<\*>**  
 This is the most common answer from the third-party devices when the command is delivered, but the execution is refused. The cause of the refusal stands after the 'feature\_abort' expression.
- 5 Clear button** Click on the **Clear** button to erase the content of the terminal window.
- 6 CEC command button panel** This panel provides the quick and easy management of CEC commands. These buttons are pre-programmed with basic functions and send commands towards the sink. The communication is displayed in the Received Command box. For the list of the commands, see the [CEC Command Sending](#) section. Both the layout and functionality are similar to the design of a remote control.

It can occur that the third-party device can receive, but not execute the command, because it is not supported by the product. Check the accepted commands in the documentation of the device.

**INFO:** The first 2x2 bit of the CEC commands contains identification data of the source and destination address. In this case that is always 40.

**ATTENTION!** Make sure that the controlled unit is CEC-capable and that this function is enabled.

## 6.8. Diagnostic Tools

### 6.8.1. Frame Detector

The ports can show detailed information about the signal like full size and active video resolution. This feature is a good troubleshooter if compatibility problems occur during system installation. To access this function, open the port properties window and click on the **Frame detector** button. `#framedetector`

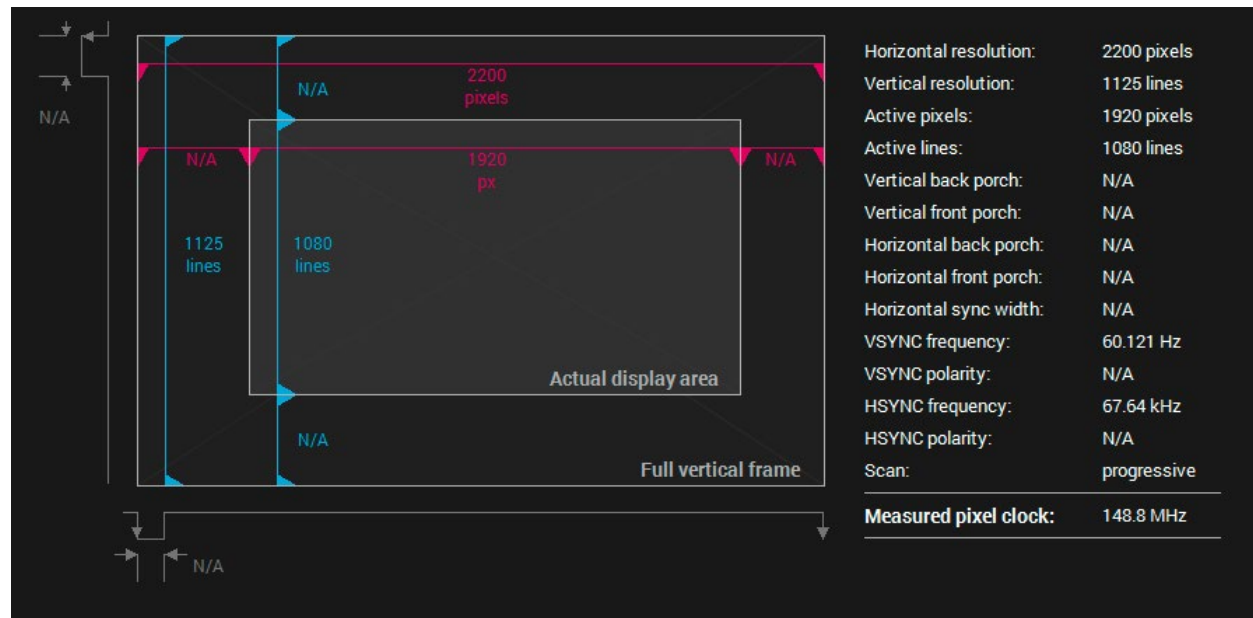

**Frame Detector Window**

Lightware's Frame Detector function works like a signal analyzer and makes it possible to determine the exact video format that is present on the port, thus helps identify many problems. E.g. actual timing parameters may differ from the expected and this may cause some displays to drop the picture.

Frame Detector measures detailed timings on the video signals just like a built-in oscilloscope, but it is much more easy to use. The actual display area shows the active video size (light grey). The dark grey area of the full frame is the blanking interval, which can contain the info frames and embedded audio data for HDMI signals. Shown values are measured directly on the signal and not retrieved only from the HDMI info frames.

### 6.8.2. Test Pattern Generator - No Sync Screen

The output ports can send a special image towards the sink devices for testing purposes.

The setting is available on output ports with the following parameters: `#nosyncscreen` `#testpattern`

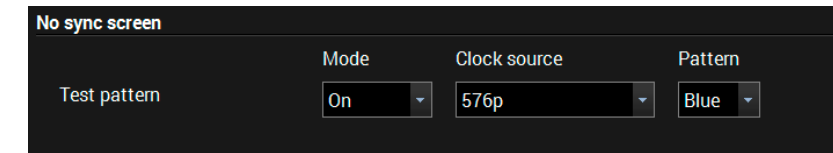

#### Mode

- **On:** the test pattern is always sent to the output port.
- **Off:** the test pattern generator is off.
- **No signal:** the test pattern generator is switched on if no video signal is switched to the given output port.

#### Clock source

- 480p / 576p / Original video signal: the clock frequency of the test pattern.

#### Pattern

- Red / Green / Blue / Black / White / Ramp / Chess / Bar / Cycle. Cycle setting means all the patterns are changed sequentially approx. every 2 seconds.

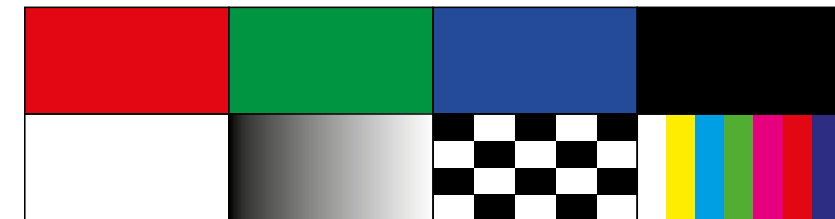

**Test patterns**

**ATTENTION!** The Mode can be set individually on each port, but the Clock source and Pattern settings are the same on the O1-O3 and O2-O4 output ports.

## 6.9. Presets Tab

The matrix has six user-programmable presets. Each preset stores a configuration regarding the crosspoint and mute state for all inputs/outputs. All presets are stored in a non-volatile memory; the router keeps presets even in the case of power down. The presets can be run from the front panel or by sending protocol commands, too.

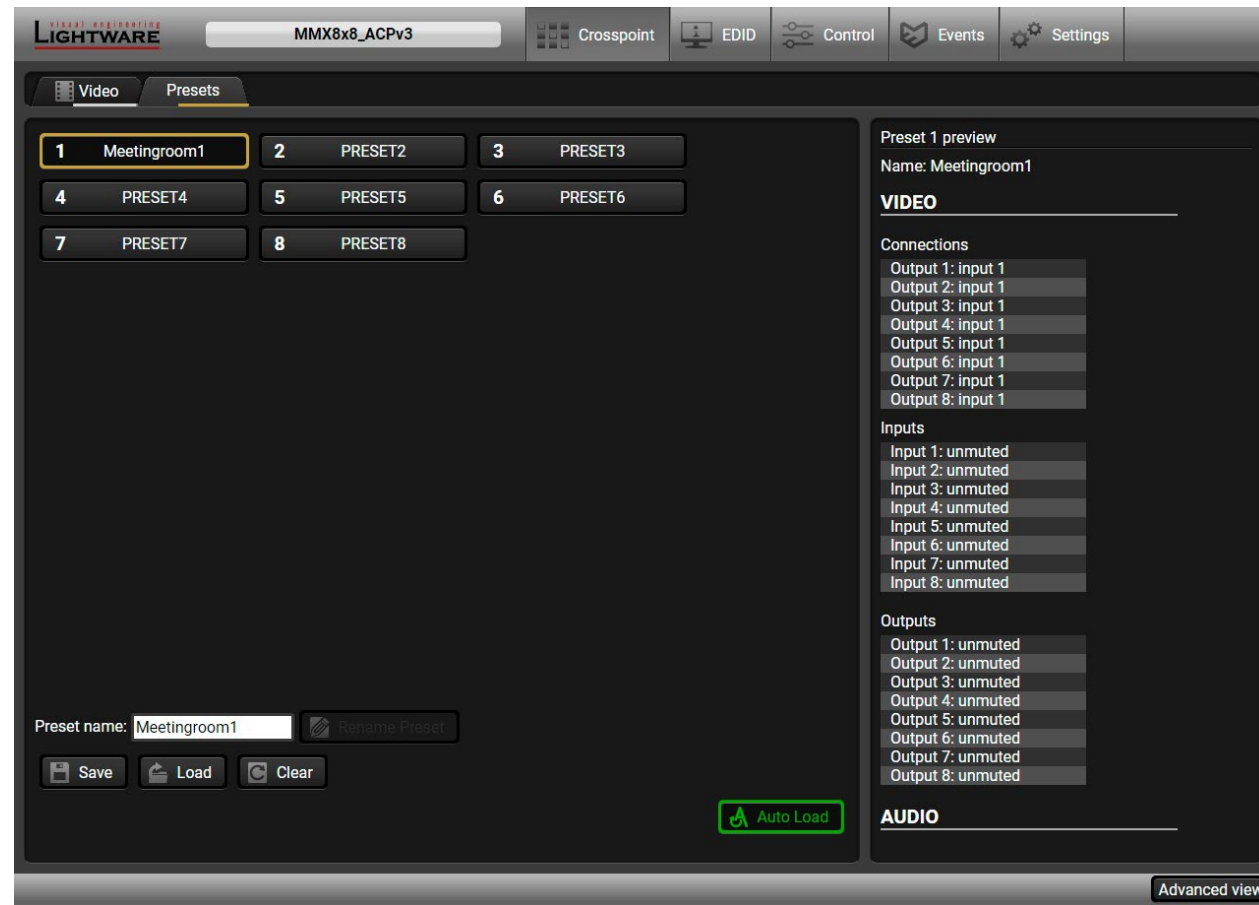

### Loading a Preset

**Step 1.** Select the **Presets** tab from the **Crosspoint** menu.

**Step 2.** Select the desired preset; check the **Preview** panel and press the **Load** button. Press **Yes** in the confirmation window.

**INFO:** Presets that were saved by the front panel buttons previously are listed with names Preset1.. Preset8 as default. See the corresponding [Save or Load a Preset](#) section.

### Saving a Preset

**Step 1.** Arrange the desired crosspoint connections.

**Step 2.** Select the Presets tab from the Crosspoint menu and choose a target preset slot from Preset 1. to Preset 6. Type the desired Preset name in the indicated text field, up to 16 characters. The following are allowed when naming: letters (A-Z and a-z), hyphen (-), underscore (\_), and numbers (0-9). Confirm it with the **Rename Preset** button.

**Step 3.** Press the **Save** button and **Yes** to confirm storing the configuration.

### Renaming a Preset

**Step 1.** Select the desired preset that you want to rename.

**Step 2.** Type the desired name and press the **Rename Preset** button.

### Deleting a Preset

**Step 1.** Select the desired preset that you want to delete.

**Step 2.** Press the **Clear** button and **Yes** to confirm.

### Auto Load Mode

When the **Auto Load** button is highlighted in green, the mode is active. In this case, confirmation is not required: the selected preset is loaded immediately when the button is pressed.



Save



Rename preset



Clear

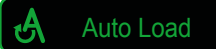

Auto Load



Load











## 6.10. EDID Menu

Advanced EDID Management can be accessed by selecting the EDID menu. There are two panels: the left one contains Source EDIDs, the right one contains Destination places where the EDIDs can be emulated or copied.



EDID Menu

### Control buttons

-  **Export** Exporting an EDID (save to a file)
-  **Import** Importing an EDID (load from a file)
-  **Info** Display EDID Summary window
-  **Edit** Opening Advanced EDID Editor with the selected EDID
-  **Create** Opening Easy EDID Creator
-  Executing EDID emulation or copying (Transfer button)
-  **Delete selected** Deleting EDID (from User memory)
-  **Select all** Selecting all memory places in the right panel
-  **Select none** Selecting none of the memory places in the right panel

INFO: By clicking on the ▼ icon in the header of the EDIDs, the EDID list is ordered by the selected column. Clicking on the Q icon makes the text field editable and filters the typed letters.*#new*

### 6.10.1. Sources and Destinations

The EDID memory consists of four parts: *# edid*

- **Factory** EDID list shows the pre-programmed EDIDs (F1-F149).
- **Dynamic** EDID list shows the display device connected to the device's outputs. The unit stores the last display devices' EDID on either output, so there is an EDID shown even if there is no display device attached to the output port at the moment.
- **User memory** locations can be used to save custom EDIDs.

In the MMX8x8-HDMI-4K-A model: (U1 – U24)

- **Emulated** EDID list shows the currently emulated EDID for the inputs. The source column displays the memory location that the current EDID was routed from.

The source reads the EDID from the Emulated EDID memory on the INPUT port. Any EDID from any of the User/Factory/Dynamic EDID lists can be copied to the user memory.

There are two types of emulation: **static** and **dynamic**.

- **Static EDID emulation:** an EDID from the Factory or User EDID list is selected. Thus, the Emulated EDID remains the same until the user emulates another EDID.
- **Dynamic EDID emulation:** it can be enabled by selecting D1-D4 EDID memory. The attached monitor's EDID is copied to the input; if a new monitor is attached to the output, the emulated EDID changes automatically.

### 6.10.2. EDID Operations

#### Changing Emulated EDID

- Step 1.** Choose the desired **EDID list** on the source panel and select an EDID.
- Step 2.** Press the **Emulated** button on the top of the Destination panel.
- Step 3.** Select the desired port on the right panel (one or more ports can be selected); the EDID(s) will be highlighted in yellow.
- Step 4.** Press the **Transfer** button to change the emulated EDID.

#### Learning an EDID

The process is the same as changing the emulated EDID; the only difference is the Destination panel: press the **User** button. Thus, one or more EDIDs can be copied into the user memory either from the factory memory or from a connected sink (Dynamic).

#### Exporting an EDID

**ATTENTION!** This function is working on Windows and macOS operating systems and under Firefox or Chrome web browsers only.

Source EDID can be downloaded as a file (\*.bin, \*.dat or \*.edid) to the computer.

- Step 1.** Select the desired **EDID** from the **Source** panel (highlighted in yellow).
- Step 2.** Press the **Export** button to open the dialog box and **save** the file to the computer.

### Importing an EDID

Previously saved EDID (\*.bin, \*.dat or \*.edid file) can be uploaded to the **user memory**:



- Step 1.** Select the **User** tab in the left panel and select a memory slot.
- Step 2.** Press the **Import** button below the Source panel.
- Step 3.** Browse the file in the opening window, then press the **Open** button. The browsed EDID is imported into the selected User memory.

**ATTENTION!** The imported EDID overwrites the selected memory place even if it is not empty.

### Deleting EDID(s)

The EDID(s) from User memory can be deleted as follows:



- Step 1.** Select the **User** tab in the left panel.
- Step 2.** Select the desired memory slot(s); one or more can be selected (**Select all** and **Select None** buttons can be used). The EDID(s) will be highlighted with yellow.
- Step 3.** Press the **Delete selected** button to delete the EDID(s).

### 6.10.3. EDID Summary Window

Select an EDID from the Source panel and press the **Info** button to display the EDID summary.

**General**

EDID version: 1  
 EDID revision: 4  
 Manufacturer ID: LWR (Lightware Visual Engineering)  
 Product ID: 0000  
 Monitor serial number: Not present  
 Year of manufacture: 2010  
 Week of manufacture: Not Used  
 Signal interface: Digital  
 Separate Sync H&V: -  
 Composite sync on H: -  
 Sync on green: -  
 Serration on VS: -  
 Color depth: Undefined  
 Interface standard: HDMI-a is supported  
 Color spaces: RGB 4:4:4 & YCrCb 4:4:4  
 Aspect ratio: 0  
 Display size: 0 cm X 0 cm

### 6.10.4. Editing an EDID

Select an EDID from the left panel and press the **Edit** button to display the Advanced EDID Editor window. The editor can read and write all descriptors that are defined in the standards, including the additional CEA extension. Any EDID from the device's memory or a saved EDID file can be loaded into the editor. The software resolves the raw EDID and displays it as readable information to the user. All descriptors can be edited, saved in an EDID file, or uploaded to the User memory. For more details about EDID Editor, please visit our website ([www.lightware.com](http://www.lightware.com)) and download the [EDID Editor Application note](#).

**Basic EDID**

- Vendor / Product Information
- Display Parameters
- Power Management and Features
- Gamma / Color and Established Timings
- Standard Timings
- Preferred Timing Mode
- 2nd Descriptor Field
- 3rd Descriptor Field
- 4th Descriptor Field
- CEA Extension
- General
- Video Data
- Audio Data
- Speaker Allocation Data
- HDMI VSDB
- HDMI Forum VSDB
- YCbCr 4:2:0 VDB
- YCbCr 4:2:0 Capability Map
- Colorimetry
- High Dynamic Range
- Detailed Timing Descriptor #1
- Detailed Timing Descriptor #2
- Detailed Timing Descriptor #3
- Detailed Timing Descriptor #4
- Detailed Timing Descriptor #5
- Detailed Timing Descriptor #6
- Save EDID

**EDID Byte Editor**

	0	1	2	3	4	5	6	7	8	9
0	00	FF	FF	FF	FF	FF	FF	00	1E	6D
10	08	5B	40	72	05	00	03	1B	01	03
20	80	3C	22	78	EA	30	35	A7	55	4E
30	A3	26	0F	50	54	21	08	00	71	40
40	81	80	81	C0	A9	C0	D1	C0	81	00
50	01	01	01	01	04	74	00	30	F2	70
60	5A	80	B0	58	8A	00	58	54	21	00
70	00	1E	56	5E	00	A0	A0	A0	29	50
80	30	20	35	00	58	54	21	00	00	1A
90	00	00	00	FD	00	38	3D	1E	87	1E
100	00	0A	20	20	20	20	20	20	00	00
110	00	FC	00	4C	47	20	55	6C	74	72
120	61	20	48	44	0A	20	01	D2		

EDID Editor Window

### 6.10.5. Creating an EDID

Since the Advanced EDID Editor mentioned above needs more complex knowledge about EDID, Lightware introduced a wizard-like interface for fast and easy EDID creation. With Easy EDID Creator it is possible to create custom EDIDs in four simple steps. For more details about EDID Editor, please visit our website ([www.lightware.com](http://www.lightware.com)) and download the [EDID Editor Application note](#).

**Select Resolution & Interface**

Welcome to the Easy EDID Creator!

With this software you are able to create a unique EDID according to your demands. Details can be added or changed in the Advanced EDID Editor later if needed.

Please select the format type and the preferred resolution. If you don't find the proper mode in the list, use the Custom format type setting, enter the resolution and the program will estimate the best blanking times.

Important notes:

- If you want to send audio then you must select HDMI or DisplayPort. DVI and VGA do not support audio transmission.
- Most DVI displays are not able to process HDMI signals. If you have a DVI display, please check its specifications.
- The supported color depth will be 24bits/pixel by default.

Format type:

Resolution:

Interface type:

*Easy EDID Creator Wizard*

## 6.11. Control Menu

### 6.11.1. RS-232 Tab

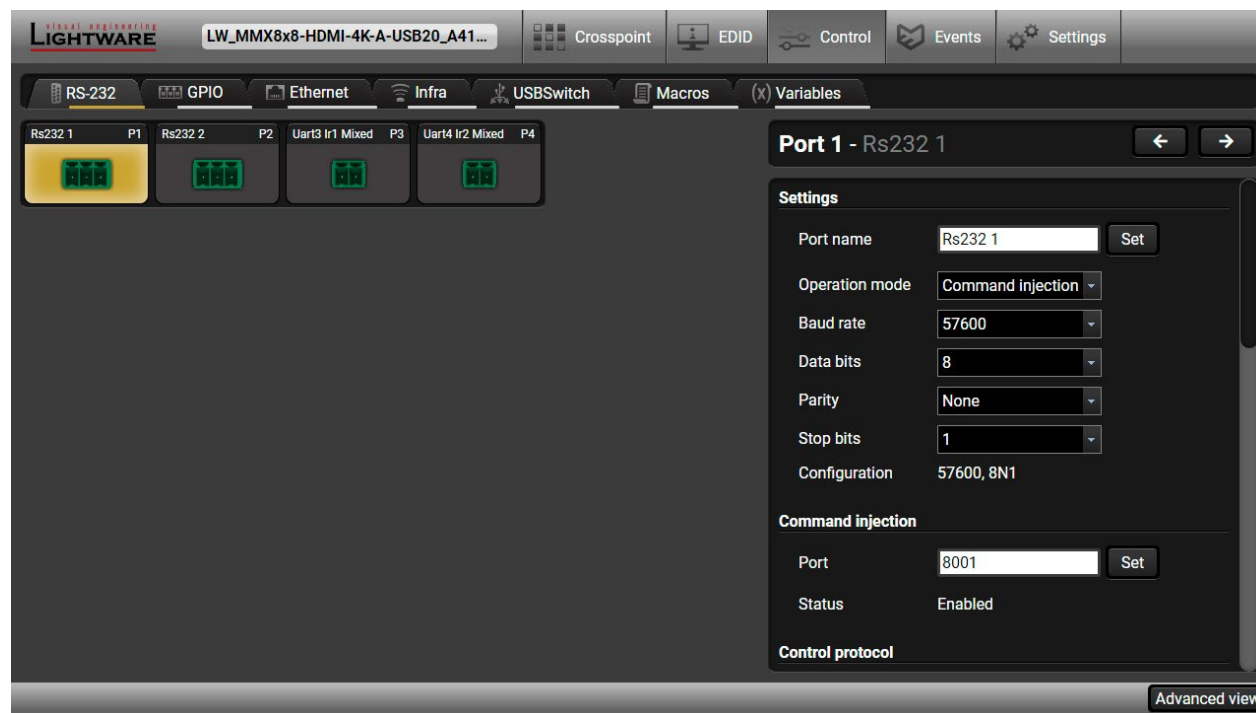

**RS-232 Tab in Control menu**

RS-232 data transmission runs on three different interfaces: `#rs-232 #rs232 #commandinjection`

- **P1, P1** channels are for bidirectional RS-232 communication. Disconnected, Control and Command Injection operation modes are available.
- **P2, P3** channels can be TTL serial ports or Infra ports depending on the transmitted data protocol. This port is able to transmit a unidirectional data flow, for example forwarding the serial messages or Infra messages that come from the Control Ethernet port (in this case the operation mode is always Command Injection). Sending serial or infra messages is also possible.

The following settings and functions are also available:

- Baud rate: 4800, 7200, 9600, 14400, 19200, 38400, 57600, 115200;
- Data bits: 8 or 9;
- Parity: None, Odd, or Even;
- Stop bits: 1, 1.5, or 2;
- Command injection port number;
- Control protocol: LW2 or LW3; `#protocol`
- Message sending `#message`
- Reloading factory defaults (see the [Factory Default Settings](#) section).

### RS-232 Message Sending

The message in the field can be sent out via the current RS-232 port. Response cannot be seen in the surface.

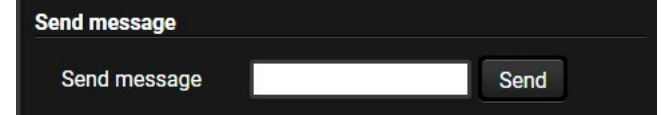

**ATTENTION!** The escaping is done automatically when sending a message via this surface. When the message is an LW3 command, it has to be closed by Carriage return and Line feed, e.g.: `CALL /MEDIA/VIDEO/XP:switch(I1:01)\x0d\x0a`.

### RS-232 Message Recognizer

This tool can be used to recognize messages coming from the RS-232 port. The message can be used as a Condition in Event manager and an Action can be defined for it.

#### Definitions

**Delimiter sequence (hex):** Each message is closed by this separator (if defined).

**Accept timeout (ms):** When the set time has passed after the last received message and delimiter was not detected, the device saves the data into the Text, Hex, and Hash properties. The timeout setting is useful if there is no special or easily defined delimiter in the incoming data, but there is a time gap between the messages.

**Text:** The recognized message in ASCII-format.

**Hex:** The recognized message in hex format.

**Hash:** Binary data that is mapped from the original message. The length of the hash is shorter, and the same message results in the same hash.



#### Working Method

A message gets recognized from the incoming data if one of the following occurs:

- The set DelimiterHex is detected in the message, or
- The set TimeOut has passed since receiving the last data bit.

### 6.11.2. GPIO Tab

**DIFFERENCE:** Only the MMX8x8-HDMI-4K-A-USB20 model has a GPIO port.

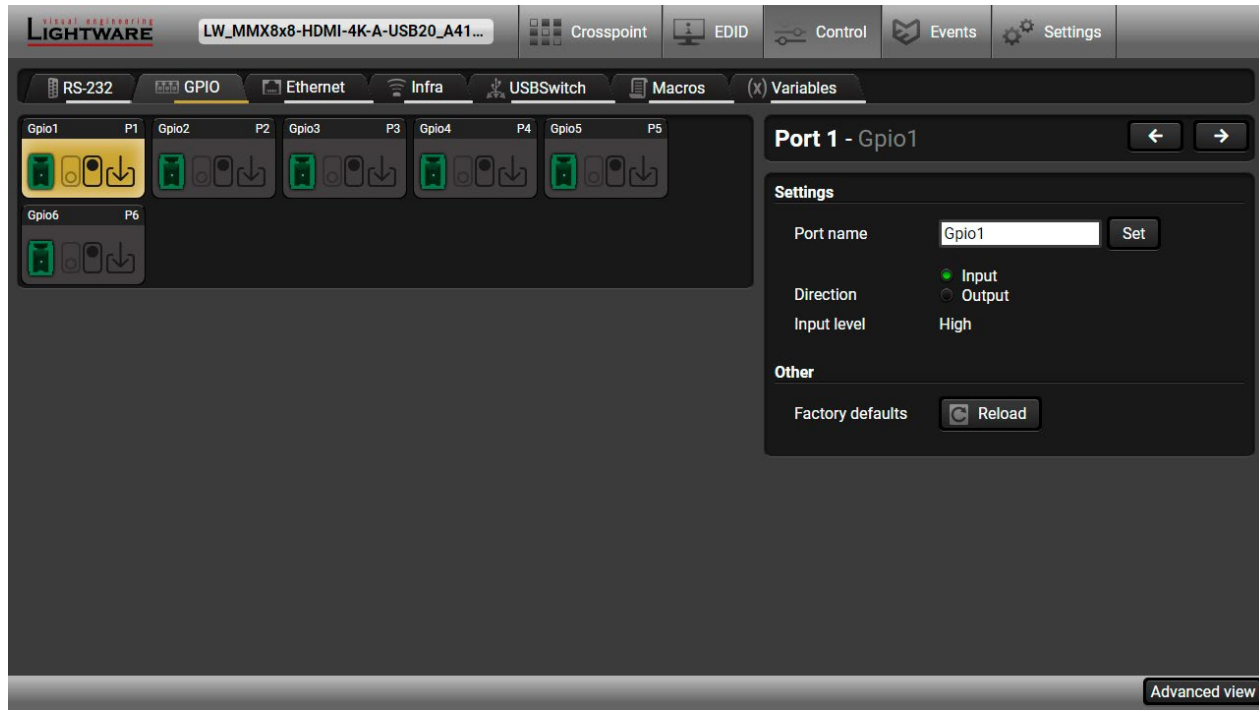

GPIO tab in the Control menu

The GPIO port has 7 pins, which operate at TTL digital signal levels and can be controlled by LDC or protocol commands. Select a GPIO pin, and the settings (pin direction and input level) are displayed both under the Port settings section and the port tiles:

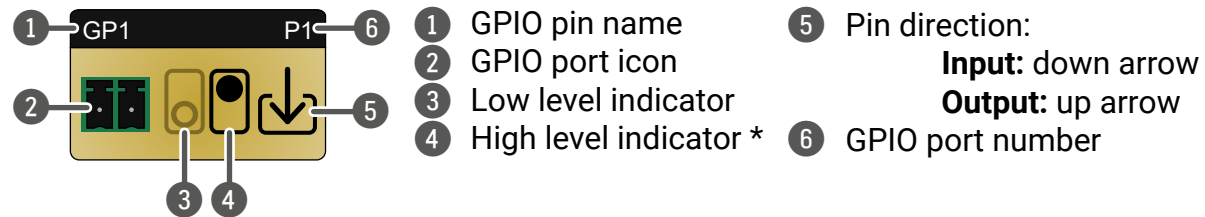

\* Highlighted with black means the current setting.

**INFO:** Output level can be set only in case of setting the pin direction to Output. In case of input direction the output level setting and the Toggle button is not available.

For more details, see the [GPIO Interface](#) section. `#gpio`

### 6.11.3. Ethernet

#### Ethernet Ports

Three ports are displayed in the Ethernet settings: Local and CPU. You can check the status of the Ethernet line via each port: the speed and the duplexity of the connection.

The following settings are available for each port:

- Enable / disable the port; \*
- Reloading factory defaults.

\* CPU Ethernet port cannot be disabled.

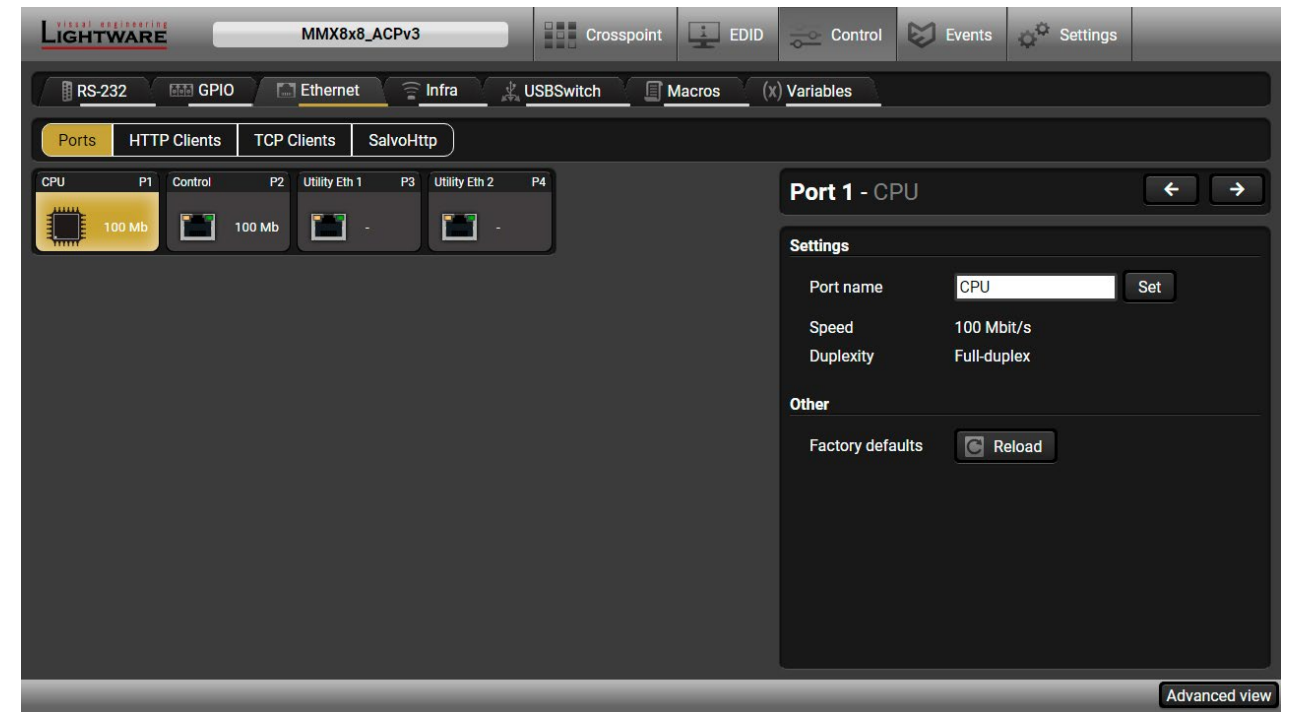

The Ports tab in the Control/Ethernet menu

### HTTP Clients (HTTP Post and Put Message Sending)

**ATTENTION!** This feature means posting or putting HTTP messages from the Lightware device to another device. Encrypted transmission (HTTPS) is not supported.

The HTTP Clients tab allows sending HTTP post and put messages to the desired server IP:port no. Control commands can be sent to the target device, but it is not suitable for processing the response (e.g. querying a parameter/status), since the response is just an acknowledge (ACK). *#http*

The feature is available also by LW3 commands, see the [HTTP Messaging](#) section.

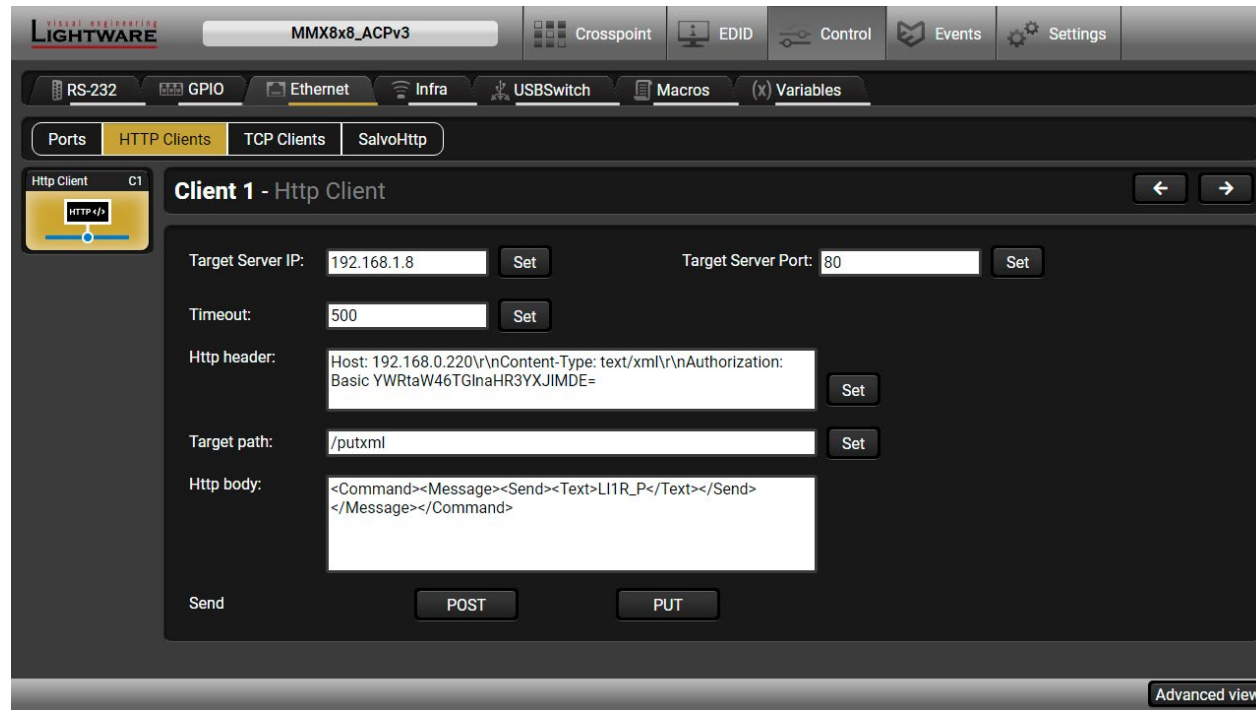

*HTTP Clients tab in the Control/Ethernet menu*

When you press the enter in the **Http header** or **Http body** text box, the `\r\n` is added automatically.

### TCP Clients (TCP Message Recognizer)

This tab is for the preparation and monitoring interface for the TCP recognizer feature. The incoming TCP messages can be detected, which may trigger Event Manager Actions. A simple example can be seen in the [TCP Recognizer](#) section. *#tcprecognizer #message*

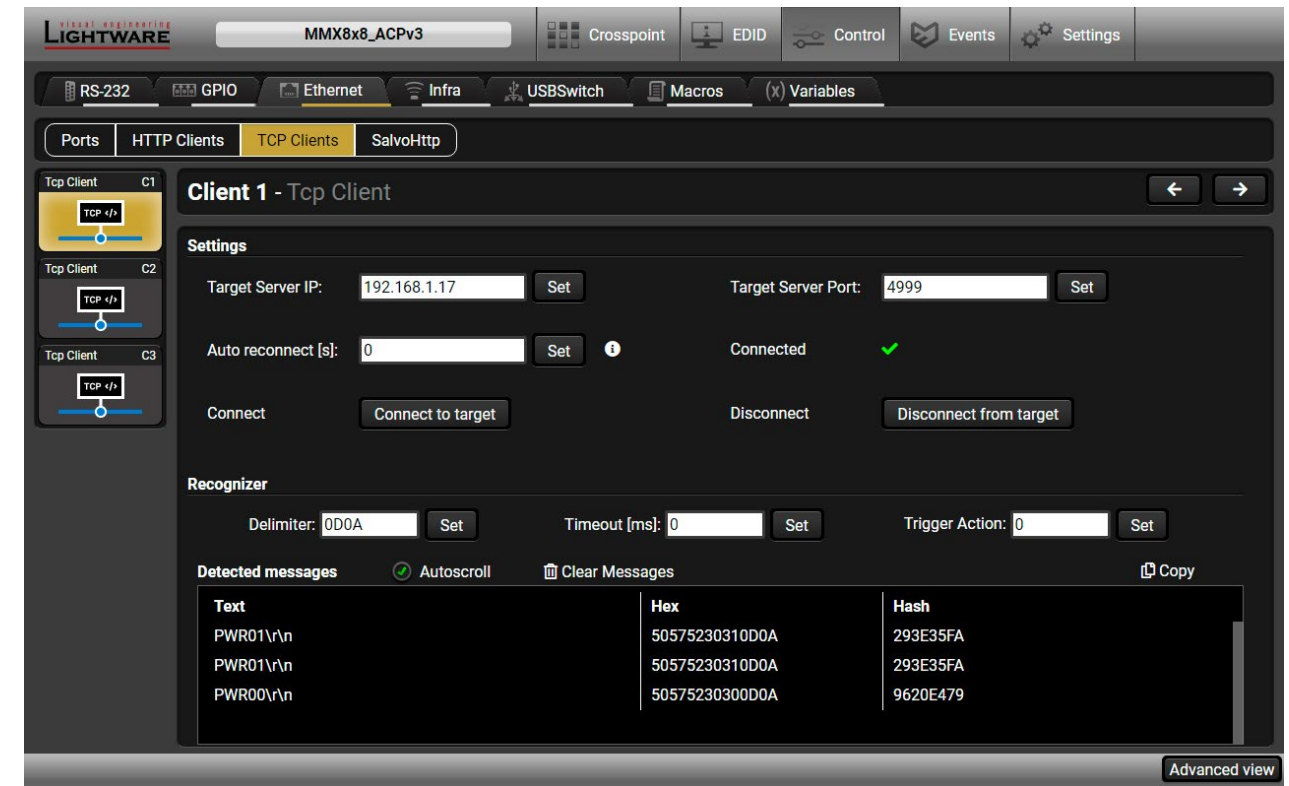

*TCP Clients tab in the Control/Ethernet menu*

The target device has to be set as a TCP client (three clients can be set):

- Step 1.** Type and set the **Target IP address**.
- Step 2.** Type and set the **TCP port number**.
- Step 3.** Make sure the same **TCP port is opened** and Enabled in the target device.
- Step 4.** Press the **Connect to target** button.
- Step 5.** Make the target device send a message and check it in the Detected messages list.
  - **Auto reconnect:** Numeric value; sets the time (seconds) between the automatic reconnections.
  - **Delimiter:** When the delimiter hex string is detected in the incoming data, the message is saved from the first bit until the delimiter (or the data between the two delimiters).
  - **Timeout:** If there is no response within the set time interval (milliseconds), the data that is received from the last delimiter will be accepted.
  - **Trigger Action:** If data is received that is closed with the recognized delimiter, an Action can be run. Type the number of the Event (without letter 'E'). *#new*

### SalvoHttp Status Page (Receiving HTTP Message)

**ATTENTION!** This feature means sending HTTP messages from an external device to the Lightware device. Encrypted transmission (HTTPS) is not supported.

In this case, a batch of commands can be sent over HTTP to the Lightware device for processing. Post the commands to the <IP\_address>/protocol.lw3 address, and the commands are processed immediately and sequentially. *#http*

Control commands can be sent to the Lightware device, but it is not suitable for querying a parameter/status, since the LW3 responses are not sent back to the sender.

**ATTENTION!** If the [Cleartext Login \(Login Settings\)](#) is enabled in the device, the login has to be the first command. No commands will be processed without a successful login. See the syntax in the [Cleartext Login Protection](#) section.

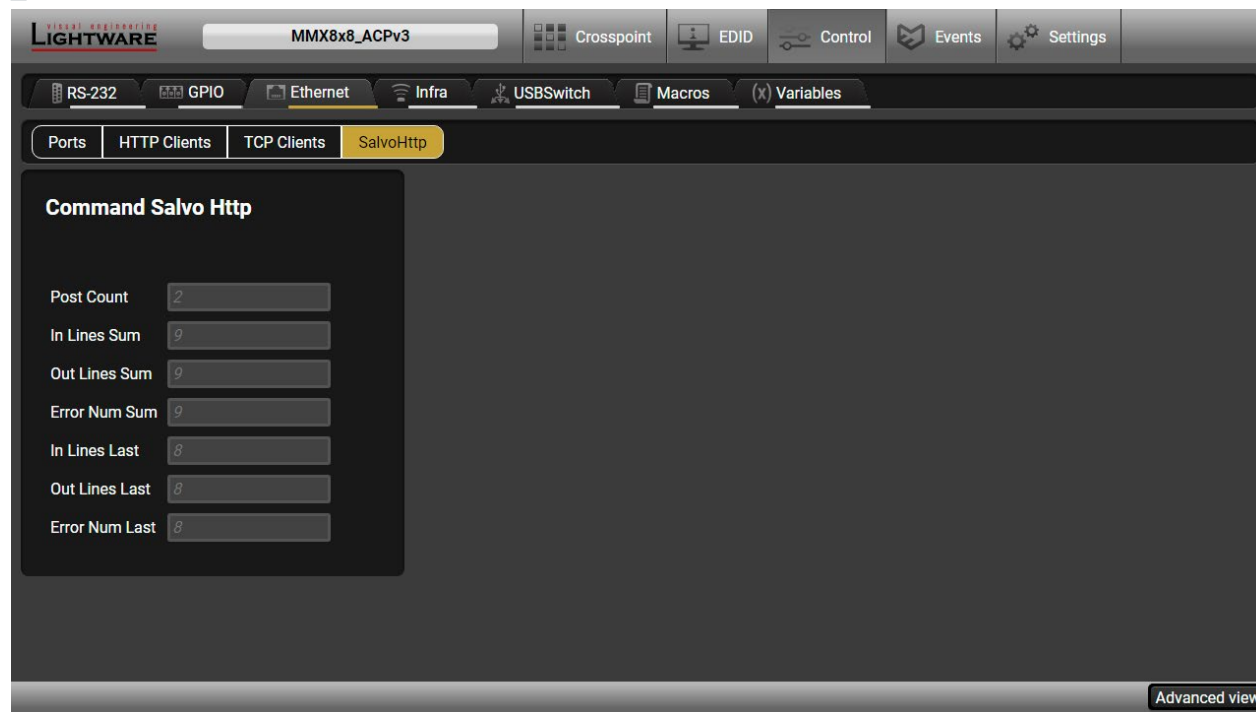

*SalvoHttp tab in the Control/Ethernet menu*

### 6.11.4. Infra Tab

**ATTENTION!** The device has no built-in Infrared transmitter. For the complete usage attach an IR emitter unit to the IR OUT connector. *#infra #infrared*

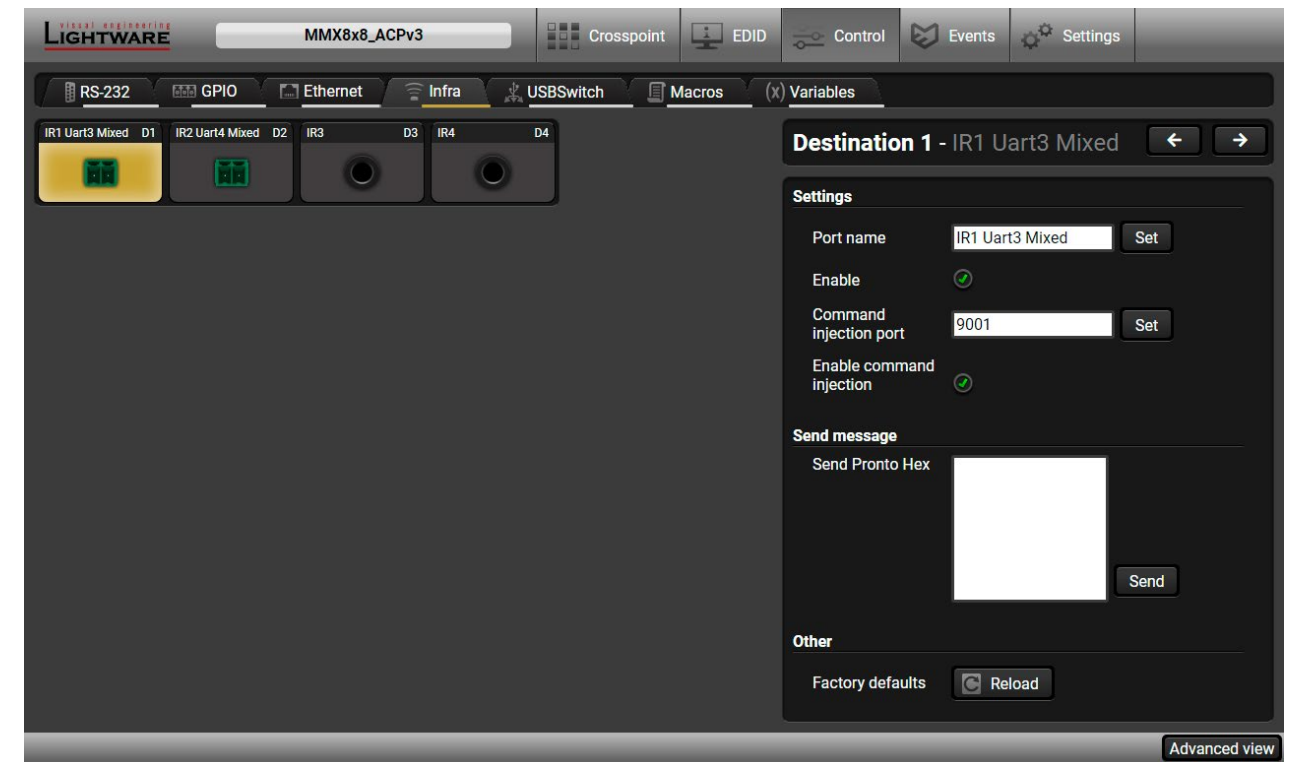

*Infra tab in the Control menu*

All the infra ports are transmitters, and they are able to forward the Infra message that comes from the Control Ethernet port (the operation mode is always Command Injection).

The following settings are also available:

- Port name
- Enable / disable the port;
- Port number
- Enable / disable command injection
- Message sending function (little-endian prontoshex code) For more details, see the [Sending Pronto Hex Codes in Little-endian Format](#) section. *#message*
- Reloading factory defaults (see factory default settings in the [Factory Default Settings](#) section).

### 6.11.5. USB Switch Tab

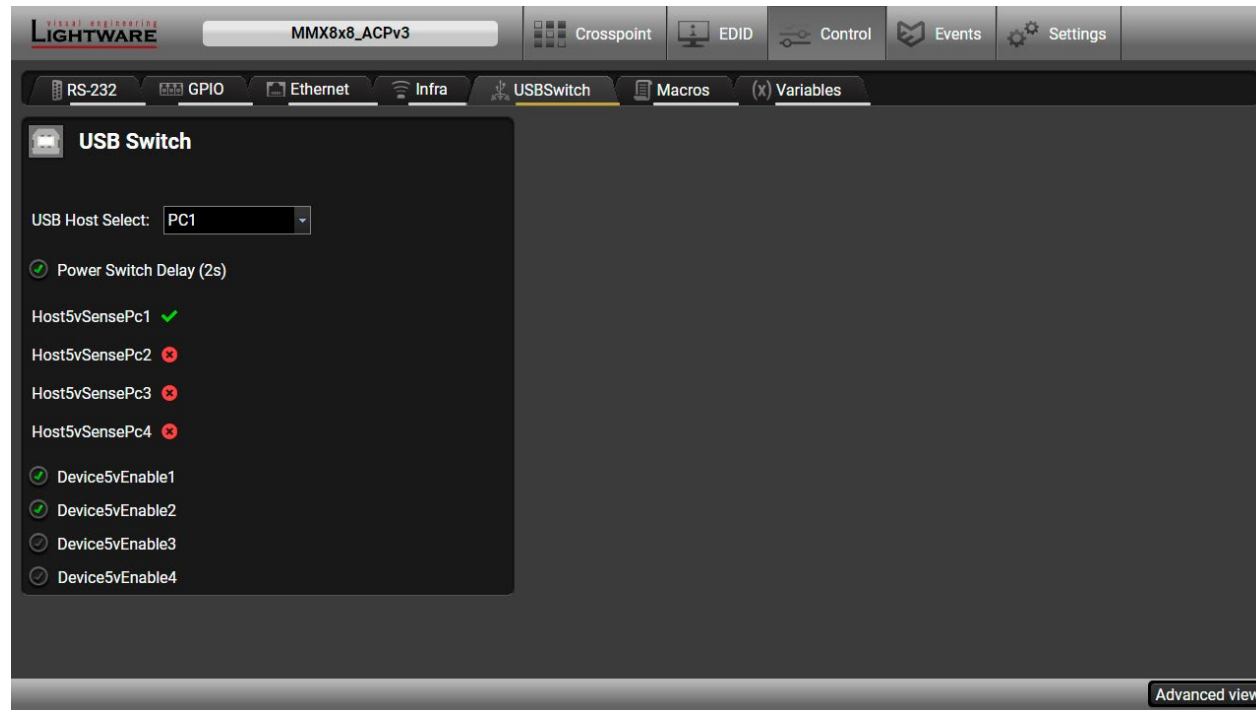

**DIFFERENCE:** Only the MMX8x8-HDMI-4K-A-USB20 model has this Tab. *#new*

The following settings are available:

- USB Host Select: PC1 / PC2 / PC3 / PC4

One host can be active at the same time of the four.

- Enabling the Power Switch Delay: After switching the hosts (on USB-B ports), this feature turns off the 5V power automatically for 2 seconds of all devices (on USB-A ports).

**INFO:** After switching between the hosts, some connected USB devices need to be reset to operate properly after the switching. Enabling power switch delay function turns off the 5V power of the connected device for 2 seconds, and the device restarts.

- Host5vSensePc gives feedback about the connected hosts.
- Device5VEnable allows sending 5V power to the device. *#usb*

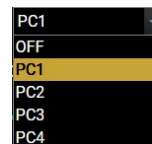

### 6.11.6. Macros

**DEFINITION:** A macro is a batch of pre-defined commands stored in the device. *#macro #new*

You can create your custom macros in a file, upload it to the device and run at any time. The number of the macros depends on the device type, for example MMX8x8 can handle up to 50 macros.

#### Important Notes about Macros

- The macros are stored in device presets.
- The commands of a macro are executed sequentially (even if error happens at a command).
- Macros allow long commands that are suitable for e.g. infra code sending.
- Macros cannot be edited in the device.
- Macros are not saved when backup is created. See the [Configuration Cloning \(Backup Tab\)](#) section.

#### Macro File Structure

##### Format:

```
<preset_name>
;Begin <macro1_name>
<LW3_commands>
;End <macro1_name>
;Begin <macro2_name>
<LW3_commands>
;End <macro2_name>
```

##### Example:

```
;myDeviceMacros
;Begin myMacro1
CALL /MEDIA/VIDEO/XP:unmuteSource (I3)
CALL /MEDIA/VIDEO/XP:switch (I3:O1;I3:O2)
;End myMacro1
;Begin myMacro2
CALL /MEDIA/VIDEO/XP:unmuteSource (I4)
CALL /MEDIA/VIDEO/XP:switch (I4:O1;I4:O2)
;End myMacro2
```

**<preset\_name>**: it will be displayed in the Settings/Backup submenu (device configurations list).

**<macro\_name>**: each Macro must have a unique name.

**<LW3\_commands>**: LW3 SET and CALL commands. Syntax is not checked, error is not reported.

**ATTENTION!** If you use the same name for a new macro, the existing one will be deleted.

Open a simple text editor and save the file with 'LW3' extension.

#### Uploading New Macros into a New Preset

The recommended way for macros is to use a Device configuration preset for this purpose exclusively. When you have to add new macros or change any of them, use the dedicated preset. The uploading steps are the following:

- Step 1.** Create the **file** with macros according to the macro file structure and save it.
- Step 2.** Navigate to the **Settings/Backup** submenu.
- Step 3.** Select a device configuration **preset** at the bottom of the page.
- Step 4.** Press the **Upload** button, browse the LW3 file and press **Open**.

**ATTENTION!** The preset and the macros of the selected slot will be erased. If there is a macro with the same name already in the device, it will be removed and the new one will be available.



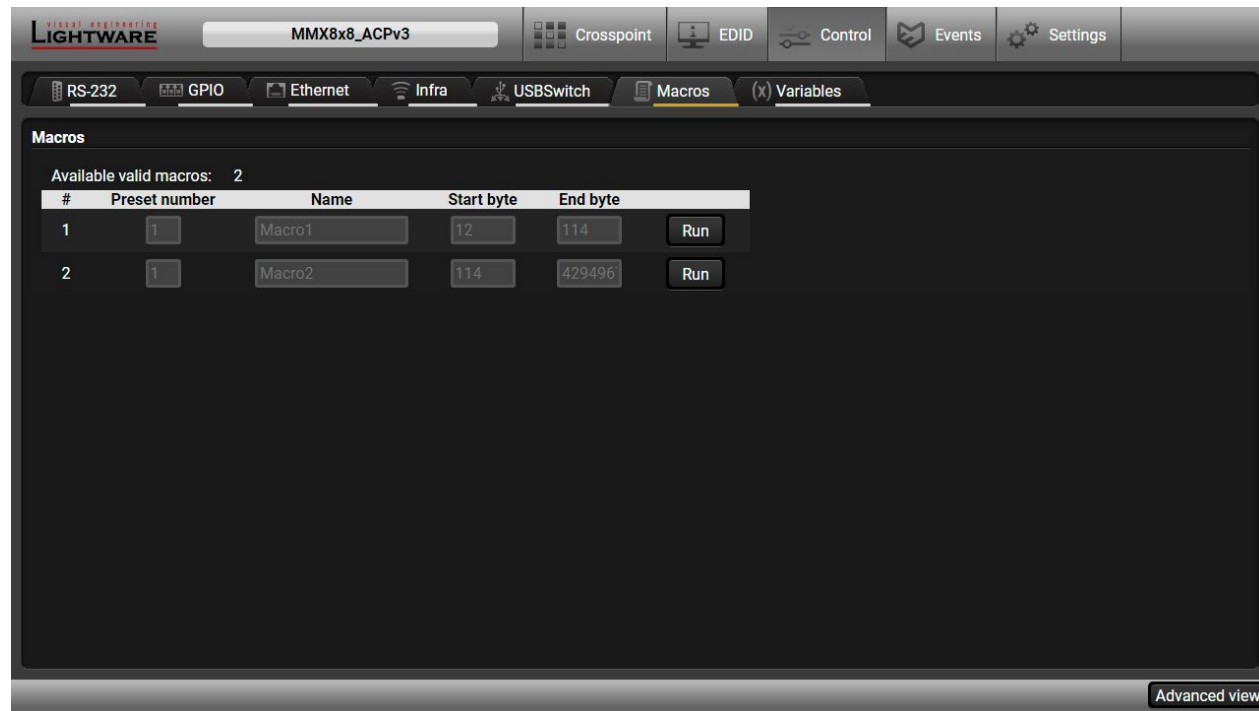

Discovered Macros in the device shown under Control/Macros submenu

### Adding Macros to an Existing Preset

- Step 1.** Navigate to the **Settings/Backup** submenu.
- Step 2.** Select a device configuration **preset** at the bottom of the page.
- Step 3.** Press the **Download** button and click on **Save** in the pop-up window.
- Step 4.** Open the file with a simple text editor and add the desired macros to the bottom of the commands between the `;Begin <macro_name>` and `;End <macro_name>` labels.
- Step 5.** Save the file and navigate to the **Settings/Backup** submenu.
- Step 6.** Select the same device configuration **preset** as selected in **Step 2**.
- Step 7.** Press the **Upload** button, browse the LW3 file and press **Open**.

If you follow the steps above, the existing macros of the selected preset will be preserved. But if there is a macro with the same name already in the device, it will be removed and the new will be available.

### Saving the Macros

When you make a backup of the device, the macros are not saved in that file. Sometimes, it is necessary to save the macros into a file and for example apply them in another (same type of) device. Follow these steps:

- Step 1.** Navigate to the **Settings/Backup** submenu.
- Step 2.** Select the device configuration **preset** that is used for the macros at the bottom of the page.
- Step 3.** Press the **Download** button and click on **Save** in the pop-up window.

### 6.11.7. Variables

A brand new area is opened by implementing the variables. You can create custom variables in number or text format, which can be used in the Event Manager. The variables can have the following properties/methods: `#variables` `#new`

- Numeric (integer) type with min/max value setting, or string-type (determined automatically)
- Increment/step the numeric value,
- Value-dependent case operations,
- Reading and storing the values of LW3 properties into string or numeric variables.
- The max length of a string variable can be 15 characters. Numeric variable is defined between -2147483648 and 2147483647.

The defined variables are stored in a non-volatile memory and the value is kept in case of a reboot.

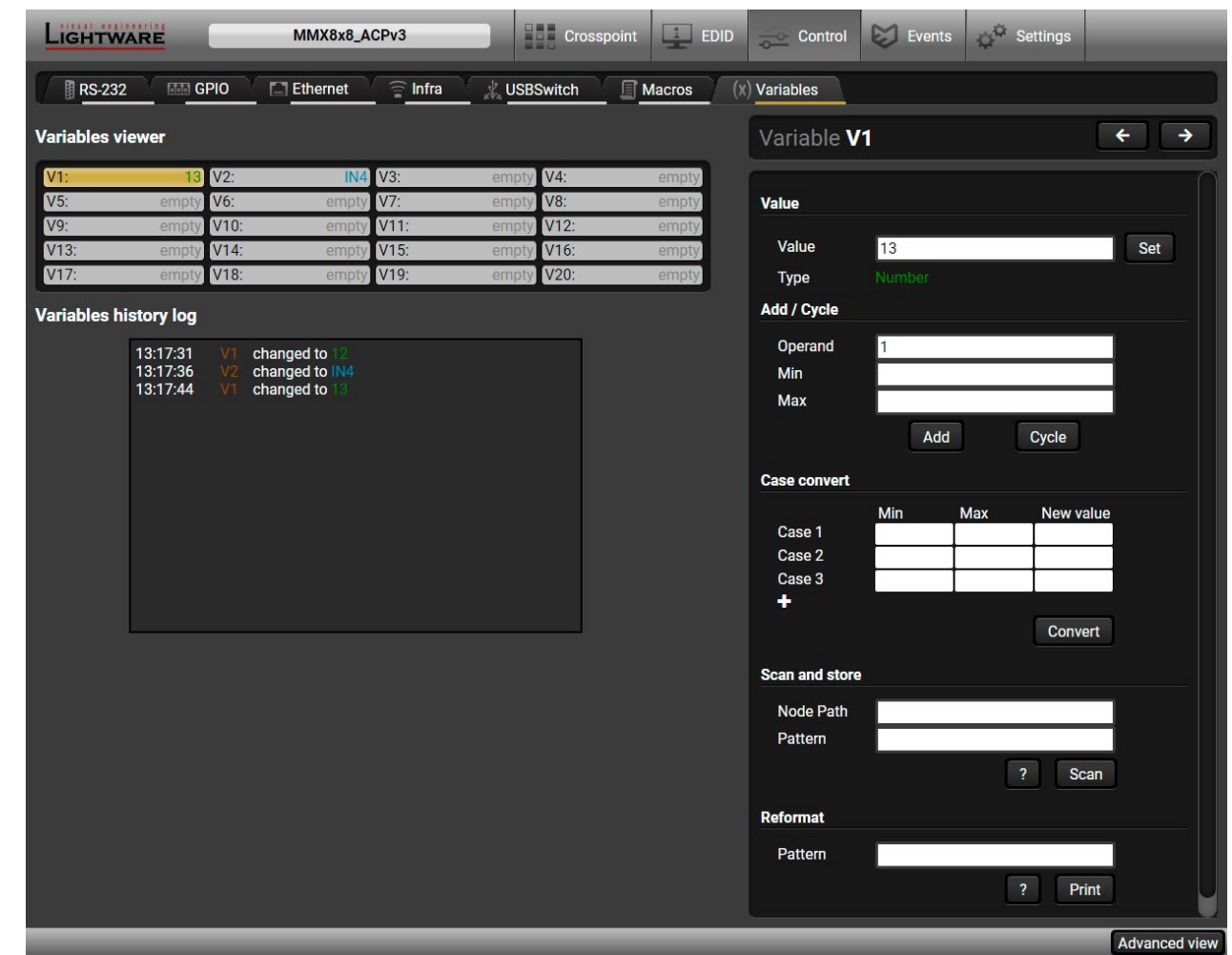

Variables tab in the Control menu

**Value Section**

You can set the value of the variable by the field. The type of the variable is determined automatically based on its value (numeric/string).

**Add / Cycle Section**

This section can be used for numeric types.

- **Operand:** the increment, the number that will be added to the current value (negative value is accepted).
- **Min (optional):** the lowest allowed value
- **Max (optional):** the highest allowed value
- **Add button:** the operand will be added to the current value. If the result would be higher than the max setting, the max will be valid; if the result would be lower than the min setting, the min will be valid
- **Cycle button:** the operand will be added to the current value. If the result would be beyond the limit (min/max), the value will be stepped to the other end of the interval.

**Examples**

The following shows the difference between the **Add** and the **Cycle** options. The input values are the same in both cases:

- **Min:** 1
- **Max:** 5
- **Operand:** 1

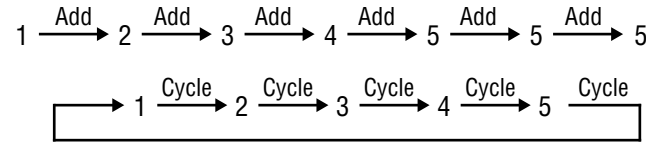

In **Add** case: when the value hits the limit (max), the operand will not increase the value any more.

In **Cycle** case: when the value hits the limit (max), the value will be stepped to the other end of the interval.

Similar case happens vice versa: when the operand is a negative number and the value hits the min value.

**TIPS AND TRICKS:** Set min=1, max=2, operand=1 and use the **cycle** method. Thus, the value of the variable can be toggled, which can be linked to a property with two states (e.g. low/high level) in Event manager.

**Case Convert**

This tool can be used to change the value of a variable if it fits in any of the defined intervals. The check and the change will be performed only if you press the **Convert** button. A typical example is when two different ranges of values have to meet:

**Incoming values:** between 0 and 255 (e.g. the slider of a controller can have these values).

**Outgoing values:** between 0 and 100 (e.g. the controlled device accepts these values).

Defined cases:

	Min	Max	New value
Case 1	1	25	10
Case 2	26	50	20
Case 3	51	75	30
Case 4	76	100	40
Case 5	101	125	50

	Min	Max	New value
Case 6	126	150	60
Case 7	151	175	70
Case 8	176	200	80
Case 9	201	225	90
Case 10	226	255	100

**Scan and Store**

This tool can be used to get the value (or a part) of an LW3 property. The defined path will be checked according to the pattern and the result will be saved into the variable (number or string type). Press the ? button to open the pattern options:

Pattern	Pattern description
%s	String of characters stopping at the first whitespace character
%<number>s	The next <number> of characters (string) stopping at the first whitespace
%c	One character
%<number>c	The next <number> of characters
%[<characters>]	Defined character set, specified between brackets
%[^<characters>]	Negated character set that will be skipped, specified between brackets
%*	Ignored part
<custom_text>	User-defined text

**Examples**

Node Path <sup>1</sup>	Property Value	Pattern <sup>1</sup>	Scanned result
/MANAGEMENT/STATUS.CpuTemperature	42 C; 0;75; 0;7	%s	42
/MANAGEMENT/STATUS.CpuFirmware	1.6.0b10 r96	%12s	1.6.0b10
/MEDIA/VIDEO/XP.DestinationPortStatus	T00AA;T00AF	%6c	T00AA
/MEDIA/UART/P1.Rs232Configuration	57600, 8N1	%*[^,], %s	8N1
/MEDIA/AUDIO/XP.SourcePortStatus	T000A;T000B;T000F	%*6c%5c	T000B
/MANAGEMENT/UID.PackageVersion	1.6.0b12 r64	%[^b]*%	1.6.0
/MANAGEMENT/NETWORK.HostName	lightware-00005031	lightware-	00005031

<sup>1</sup> defined by the user

**Reformat**

The value of the variable can be changed by adding text as prefix and/or postfix. Type %s to indicate where to insert the original value.

**Examples**

- **Original value:** 3
- **Pattern:** input%s
- **Modified value:** input3

## 6.12. Event Manager

The feature means that the device can sense changes on its ports and is able to react according to the pre-defined settings. The development idea of the Event manager is based on users' feedbacks. In many cases internal events (such as signal present or HDCP active) are necessary for displaying, but it is not easy when the device is hard to access (e.g. built under the desk).



The Event manager can be configured to perform an action if a condition has been detected. E.g. the desired setup is that after a certain type of signal has been detected on I1 port, the port has to be switched to O1. The settings can be done via the LDC in the Control/Events tab, or by LW3 protocol commands. The number of configurable events depends on the device that you are using actually.

Numerous new ideas and requests have been received in connection with the features and settings of the Event manager since the first release. Therefore, the user interface has been re-designed and many new functions have been implemented. The Event editor can be opened by pressing the **Edit** button at each Event.

There is a **grey bar** on the left of the Event panel in each line. If a condition and an action are set and the Event is enabled, the bar is displayed in **green**.

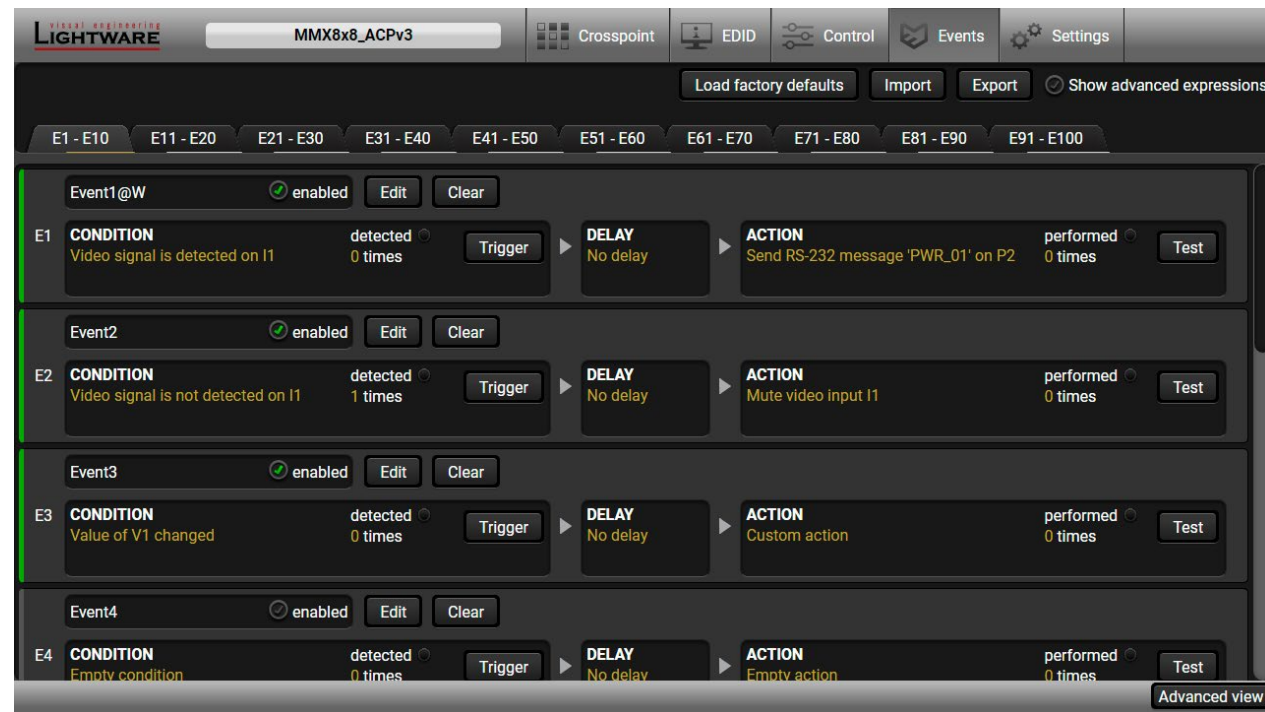

Control menu, Event Manager tab

### 6.12.1. The Event Editor

Press the **Edit** button in the desired Event line to open the Event editor window. *#eventmanager*

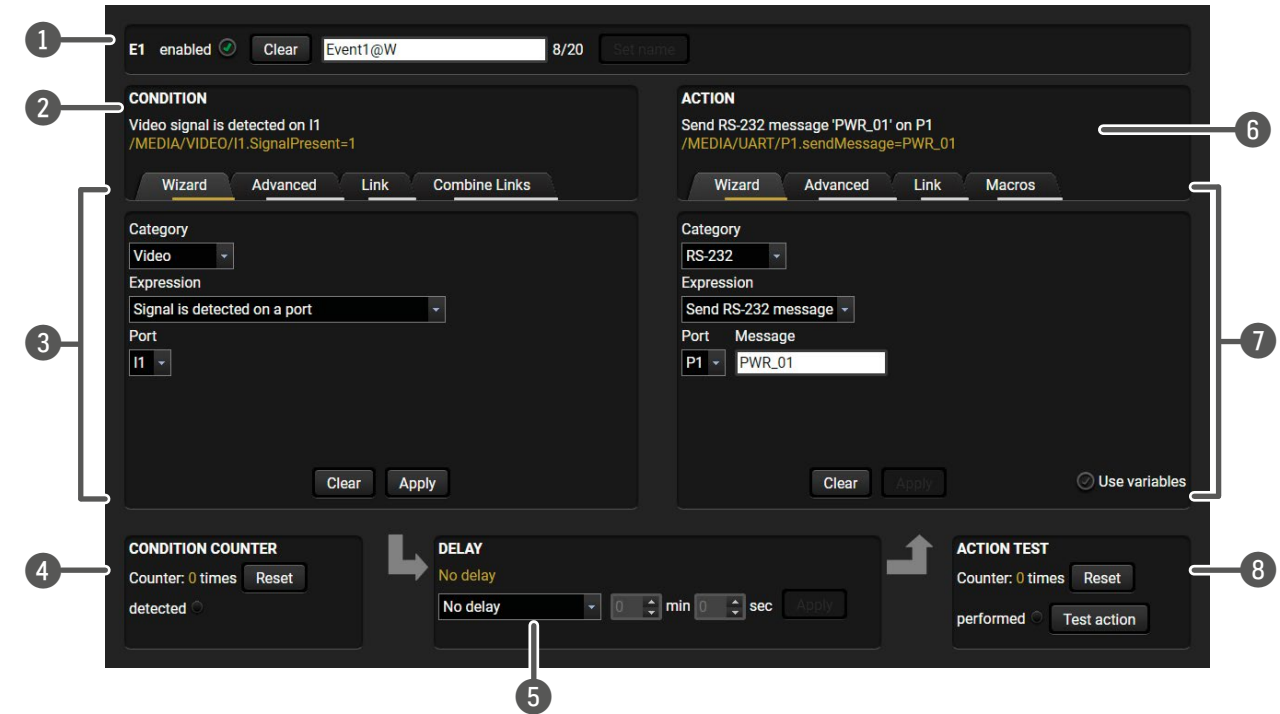

- 1 **Event header** The name of the Event is displayed. Type the desired name and press the **Set name** button. The Event can be cleared by the **Clear** button. Use the tick mark to enable/disable the Event.
- 2 **Condition header** If the condition is set, the description (white colored text) and the exact LW3 protocol expression (yellow colored text) can be seen. If the advanced mode was used, the description is "Custom condition".
- 3 **Condition panel** Different tools are available at the tabs to set the desired Condition. The parameters and settings are displayed below the buttons.
- 4 **Condition test** The set condition can be tested to see the working method in the practice.
- 5 **Delay settings** The action can be scheduled to follow the condition after the set time value.
- 6 **Action header** If the action is set, the description (white colored text) and the exact LW3 protocol expression (yellow colored text) can be seen. If the advanced mode was used, the description is "Custom action".
- 7 **Action panel** Different tools are available at the tabs to set the desired Action. The parameters and settings are displayed below the buttons.
- 8 **Action test** The set action can be tested to see the working method in the practice.

## 6.12.2. Create or Modify an Event

### Wizard Mode

The wizard mode lists the most common conditions and actions, so the user does not have to look for LW3 nodes and properties.

- Step 1.** Click on the **Edit** button of the desired Event; the **Event editor** is displayed.
- Step 2.** The wizard mode is displayed by default. Select the desired **Category** first (e.g. Audio or Video).
- Step 3.** Select the desired **Expression** from the drop-down menu. If any other parameter is necessary to be set, it is going to be displayed.
- Step 4.** Press the **Apply** button to store the settings of the Condition.

**INFO:** This mode is also available for setting the **Action**.

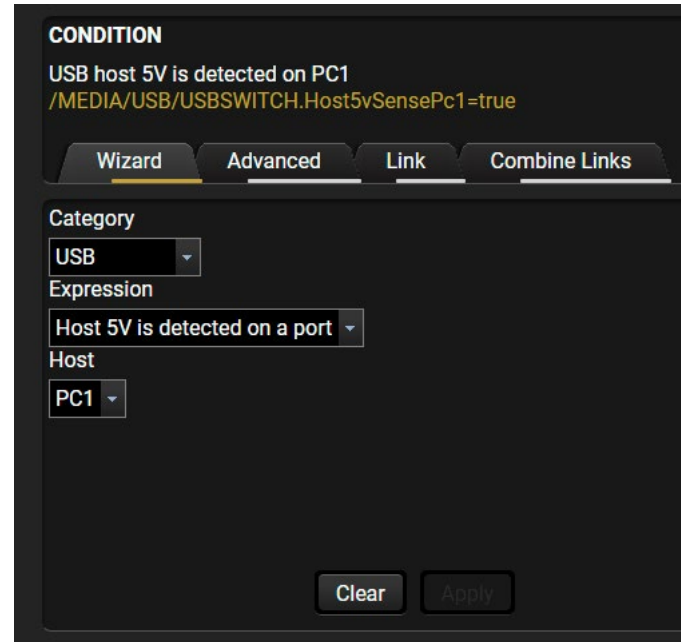

### Advanced Mode

The goal of this mode is the same as that of the wizard: set the properties and methods for conditions and actions. The difference is the number of the available and usable properties and methods of the LW3 protocol. Advanced mode allows almost all of it.

- Step 1.** Click on the **Edit** button of the desired Event; the **Event editor** is displayed.
- Step 2.** The wizard mode is the default, press the **Advanced** button. The LW3 protocol tree is displayed, showing the list of the properties in the drop-down menu. Navigate to the desired node.
- Step 3.** Select the desired **Property** from the menu. The **manual** of the property is displayed below to help select the necessary property and set the value.
- Step 4.** Set the desired **value** and **operator**, then press the **Apply** button to store the settings.

**INFO:** This mode is also available for setting the **Action**.

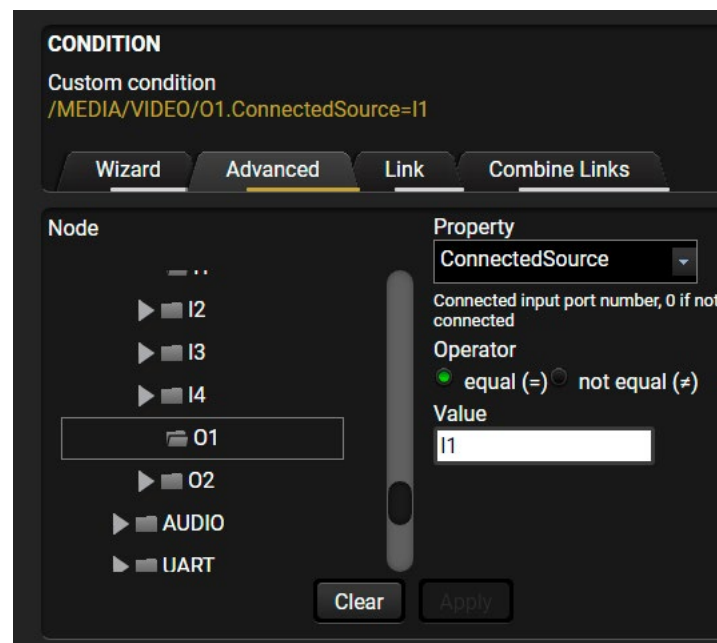

### The Link Tool

The new interface allows creating more actions for the same condition. In that case, a condition can trigger more actions. To set such an Event, the Link tool has been introduced.

- Step 1.** Click on the **Edit** button of the desired Event; the **Event editor** is displayed.
- Step 2.** The wizard mode is displayed by default, press the **Link** button.
- Step 3.** All the saved Events are analyzed and the **conditions** are listed (it takes a few seconds to finish). The **Show advanced expressions** option allows showing the exact path and setting the value of the given property.
- Step 4.** Select the desired **Condition** and press the **Apply** button to store the settings.

**INFO:** This mode is also available for setting the **Action**.

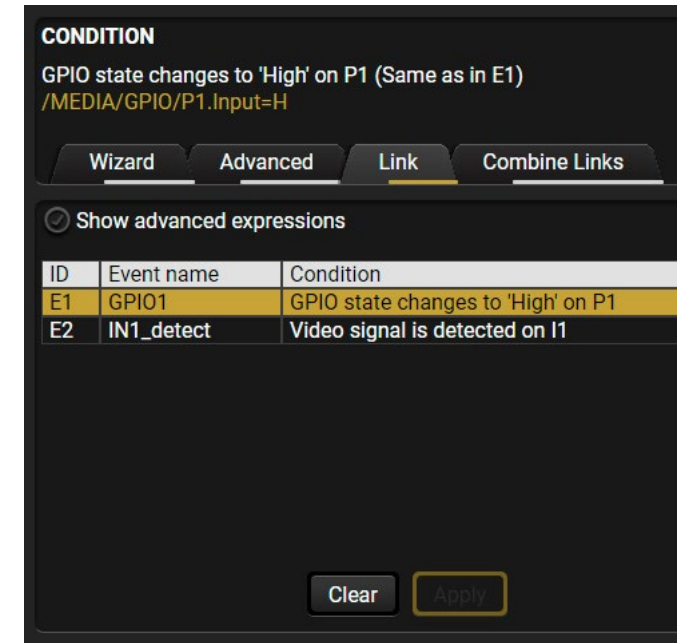

### Combine Links

The first generation of the Event Manager is able to sense a change (one condition), but in some cases that is not enough. The practical experience has shown that there is a need to examine up to four conditions as follows: one condition exists, and the other is a change that occurs. The **Combine Links** tool allows launching an Action, if the Conditions are present at the same time. Follow the steps below:

- Step 1.** Create the **Conditions** in separate Events.
- Step 2.** Create a new Event and navigate to the **Combine Links** tab in the Editor.
- Step 3.** Select the **Conditions** in the left panel.
- Step 4.** Set the desired **Action** (and do not forget to **enable** the Events).

**INFO:** This mode is available for setting the **Condition only**.

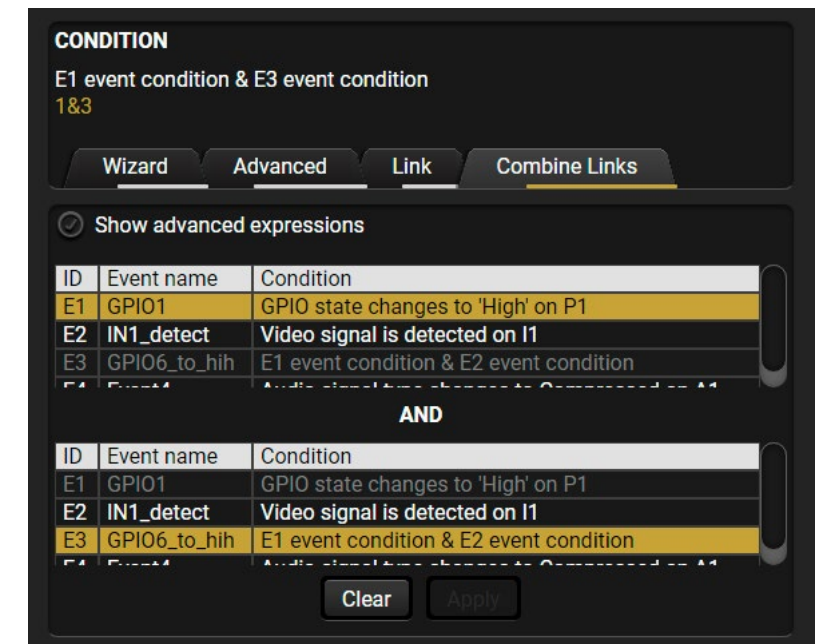

### Linking a Macro (Action)

Macros stored in the device can be run as Actions. Thus, a lot of commands can be run by using only one Event. The commands will be processed one-by-one after each other. *#macro*

- Step 1.** Click on the **Edit** button of the desired Event; the **Event editor** is displayed.
- Step 2.** The wizard mode is the default, press the **Macros** button in the **Action** panel.
- Step 3.** Select the desired **Macro** from the list, then press the **Apply** button to store the settings.

See more information about the Macro settings in the [Macros](#) section.

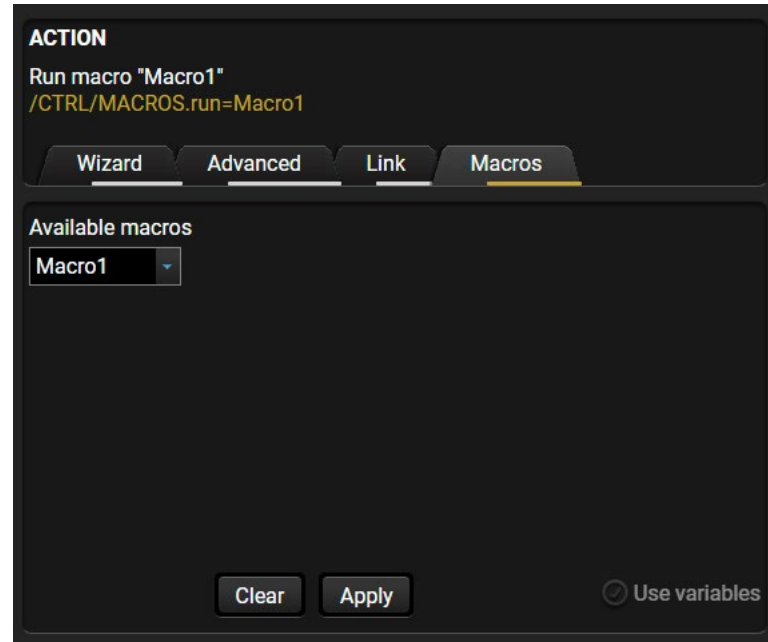

### 6.12.3. Special Tools and Accessories

#### The Name of the Event

The name of an Event can be changed by typing the new name and clicking on the **Set** button. The following characters are allowed when naming:

Letters (A-Z) and (a-z), numbers (0-9), special characters: hyphen (-), underscore (\_), and space ( ).

#### Enable or Disable an Event

The set Event can be enabled or disabled in the Event list, or directly in the Event editor window by adding/removing the **tick mark** beside the name.

#### Testing the Condition

When the desired Condition is arranged, the setting can be tested. The Event list and the Event editor contains a small panel that shows an indicator if the set condition is detected (or triggered). The **detected** mark turns green for two seconds and the **Counter** is increased. The **Counter** is reset at boot or can be reset manually by the button in Event editor.

#### Testing the Action

The method is the same as testing the Condition, but in this case, the Action can be triggered manually by pressing the **Test** button.

**TIPS AND TRICKS:** The Test button is also placed on the Action panel in the Event list. Thus, you can check the Actions without opening the Event editor.

### Delay the Action

In most cases the Action is performed immediately after the Condition is detected. But sometimes a delay is necessary between the Condition and the Action. Therefore, the new Event manager contains the Delay panel, which allows that feature with the settings below:

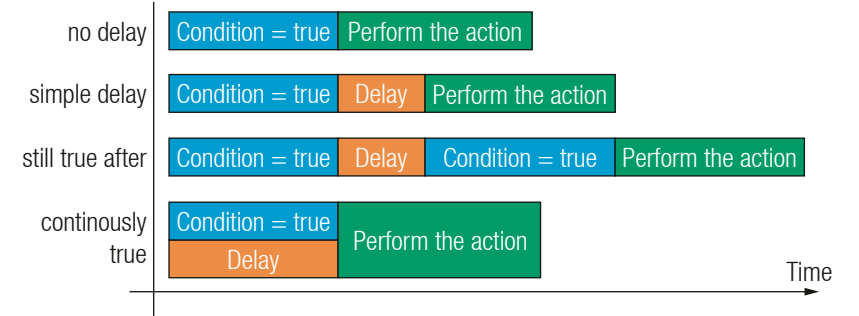

- **No delay:** when the Condition is detected, the Action is launched.
- **Simple delay:** when the Condition is detected, the Action is launched after the set time interval.
- **Still true after:** when the Condition is detected, the Action is launched after the set time interval only if the Condition still exists.
- **Continuously true:** when the Condition is detected, the Action is launched after the set time interval only if the Condition has been existing continuously.

**TIPS AND TRICKS:** **Show advanced expressions** option is a useful tool when you look for the path or value of a property, but just the expression is displayed. The option is available in the Event list window and also in the Editor.

### Variables

The variables and the tools (shown in the Control/Variables tab) can be used in the Event Manager.

#### Condition Wizard *#variables #new*

The desired variable can be checked if its value is changed to a specific value.

#### Action Wizard

The value of a variable can be set/changed by the same methods as in the Control/Variables tab:

- Setting the exact value
- Increasing the value with/without limits
- Converting the value (e.g. interval change)
- Scanning and storing, or reformatting a property/parameter

If the **Use variables** option is enabled, you can link a variable by the **\$** character. If you do so (e.g. \$1), the device will handle it as the V1 variable. You can send the value of the variable e.g. as a TCP message.

### Condition Triggering

This improvement works as if a condition is detected. When a complex control system is built, a Condition may trigger numerous Actions. A typical example is when a system is powered on and the 'ready-to-use' state has to be loaded. In this case, there could be many actions that are based on the same condition. In order to reduce the number of the commands, you can trigger one 'key' condition, which could start the whole process.

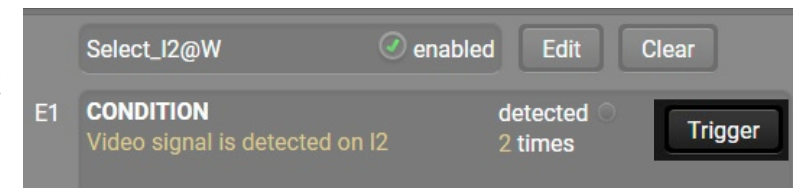

### 6.12.4. Clear One or More Event(s)

#### Clear an Event

Press the **Clear** button in the Event list or in the header section in the Event editor.

#### Clear all Events

When all the Events must be cleared, press the **Load factory defaults** button above the Event list. You will be prompted to confirm the process.

**ATTENTION!** Clicking on the Load factory defaults button means that the configuration of the buttons are also deleted, because the conditions and the actions of the buttons are saved as events.

### 6.12.5. Export and Import Events

The feature allows saving all of the Events. The backup file can be uploaded to another MMX8x8-HDMI series matrix.

#### Export all the Events

**Step 1.** Press the **Export** button above the Event list.

**Step 2.** The Save as dialog box will appear. Set the desired folder and file name, then press the **Save** button.

The generated file is a simple text file, which contains LW3 protocol commands. The file can be viewed by a simple text editor, e.g. Notepad.

**ATTENTION!** Editing the file is recommended only for expert users.

#### Import all the Events

**Step 1.** Press the **Import** button above the Event list.

**Step 2.** The Open dialog box will appear. Select the desired folder and file, then press the **Open** button.

### 6.12.6. Event Creating - Example

The following example shows you on a real-life situation how to set up an Event.

#### The Concept

The matrix is connected to a projector by the HDMI out 1 port. The matrix is also connected to the projector by the RS-232 port and can send commands via the serial line. The task is to turn on the projector when signal is detected on the HDMI out 1 port.

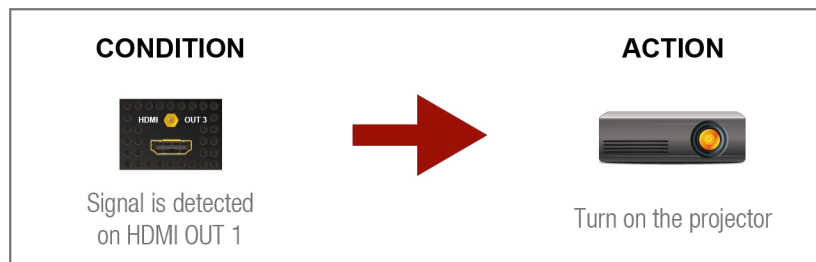

### RS-232 Settings

Make sure that the serial line is established between the matrix and the projector. Check that the RS-232 settings of the matrix are set exactly the same as is required for the projector: baud rate, data bits, parity, stop bits. The matrix needs to be set to: Control protocol: LW3; and RS-232 mode: Control. See the relevant LDC settings in the [RS-232 Tab](#) section.

### Setting the Event

You can create the Event in the Wizard in few simple steps:

**Step 1.** Set the condition.

Select the required parameters to set the condition:

- **Category:** Video;
- **Expression:** Signal is detected on a port;
- **Port:** 01.

Click on the **Apply** button to complete the procedure. When it is done, the condition appears on the upper side in textual and LW3 command format as well.



**Step 2.** Set the action.

If the condition is fulfilled, the following action needs to be launched: the receiver sends a command to the projector over the serial line:

- **Power on** - the required command which is accepted by the projector: PWR0<CR><LF>

For this instance the command has to be closed with the <CR><LF> characters, so they need to be escaped. You can use the following format for escaping:

<command<sub>1</sub>><\x0d\x0a><command<sub>2</sub>><\x0d\x0a>...  
...<command<sub>n</sub>><\x0d\x0a>

In the current case the command is: PWR0\x0d\x0a

Select the required parameters to set the action:

- **Category:** RS-232;
- **Expression:** Send RS-232 message;
- **Port:** P1;
- **Message:** PWR0\x0d\x0a

**Step 3.** Enable the Event.

Select the **E1 enabled** tick in the upper left corner to set the Event as enabled.

**INFO:** If you do not find the required category/expression/etc that you need, choose the Advanced mode in the Wizard, where the entire LW3 structure tree is available. For example, instead of signal detection you can set a specified resolution or color range too as a condition.

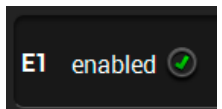
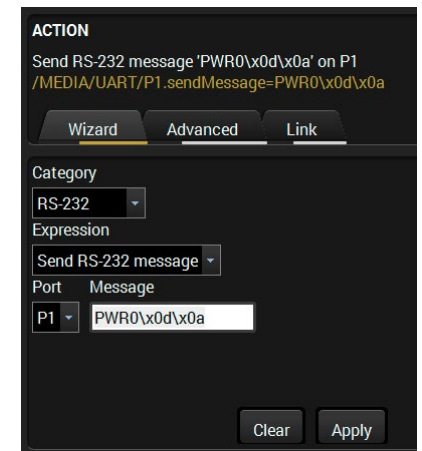

## 6.13. Settings Menu

### 6.13.1. Status

General information is shown on this tab, such as device label, part number, serial number and hardware health, voltage and temperature values.

The screenshot displays the 'Status' tab within the 'Settings' menu. The top navigation bar includes 'Status', 'Network', 'Backup', and 'System'. The main content area is divided into several sections:

- General:** Product name (MMX8x8-HDMI-4K-A-USB20), MAC address (a8:d2:36:ff:66:02), Hardware version (V10\_BAA0), Device label (MMX8x8\_USB), Part number (91310075), and Serial number (00006602).
- Built-in miniweb:** Open miniweb (Open miniweb), Upload built-in miniweb (Choose file), Actual file size (10260 bytes), Max file size limit (1048576 bytes), and Clear built-in miniweb (Clear).
- Operation:** System uptime (2 days 01h 22m 07s), Operation time (97 days 17h 19m 43s), and High temp operation time (0 days 00h 00m 00s).
- Firmware versions:** CPU firmware version (1.3.0b5 r64) and Package version (1.3.0b6 r91).
- Temperatures:** CPU temperature (51 °C), System temperature (51 °C), In temperature (47 °C), Crosspoint temperature (48 °C), Power supply temperature (45 °C), and Input board temperature (41 °C).
- Voltages:** 5 V local (5.08 V) and 3.3 V local (3.37 V).
- Reset measurements:** A 'Reset' button.

Status tab in Settings menu

The most important hardware and software related information can be found on this tab: hardware and firmware version, serial numbers, temperatures, operation time, and voltage information. Device label can be changed to a unique description via the **Set** button.

Please note that the Miniweb-related descriptions can be found in the [The Built-in Miniweb](#) section.

Clicking on the **Identify me** button results in the status and crosspoint LEDs blinking in green for 10 seconds. The feature helps identify the device itself in the rack shelf.

#devicelabel #producttype #firmwareversion #identifyme #status #serialnumber

### 6.13.2. Network

Network-related settings are available on the tab.

The screenshot displays the 'Network' tab within the 'Settings' menu. The top navigation bar includes 'Status', 'Network', 'Backup', and 'System'. The main content area is divided into several sections:

- General:** Current IP address (172.24.5.33), Current subnet mask (255.255.0.0), Current gateway address (172.24.0.1), Obtain IP address automatically (DHCP, AutoIP) (checked), Static IP address (172.24.5.33), Static subnet mask (255.255.0.0), and Static gateway address (172.24.1.1). Buttons: Apply changes, Cancel, Load factory defaults.
- TCP/IP ports and services:** LW3 control port (6107), LW2 control port enable (checked, 10001), HTTP port enable (checked, 80), HTTP POST commands enable (checked), LMDMP enable (checked). Button: Reset.
- MAC filter allowlist:** Currently connected device's MAC address: 00:09:0F:AA:00:01. Enable MAC address filtering (checked). Table:
 

#	Name	MAC address	Send	Receive	Reset	?
1	bcast	FF:FF:FF:FF:FF:FF	checked	checked	Reset	?
2	mDNS	01:00:5E:00:00:FB	checked	checked	Reset	?

Network tab in Settings menu

#### General

IP address and DHCP settings can be set on this tab. Always press the **Apply settings** button to save changes. Factory default settings can be recalled with a dedicated button.

#### TCP/IP Ports and Services

The IP Port Block feature is an additional protection for the Cleartext login, see the [Basic IT Security](#) section. There are TCP/IP ports in Lightware devices that are not protected by the login, so you can disable them if necessary. For example, due to the working method of the LW2 communication, the Cleartext login does not provide protection when an LW2 command is sent to the device, that is why the TCP port no.10001 shall be blocked manually. #dhcp #ipaddress #network #portblock

### MAC Filter Allowlist

Another level of the security is the MAC Filtering tool. You can create a list of network devices based on the MAC address that are allowed: `#macfilter`

- Controlling the device (Send option), or
- Querying parameters (Receive option) to/from the Lightware device.

Do not forget to press the **Apply changes** button to store the new settings.

**ATTENTION!** The first three lines (as seen in the picture) are factory default values and they are necessary for the proper working.

**ATTENTION!** If the device is installed in a network where it gets the IP address from a DHCP server and you plan to use the MAC filtering, make sure the MAC address of the DHCP server is added to the whitelist. Otherwise, the device will not get an IP address and will be unreachable.

#### 6.13.3. Backup

Details about this function can be found in the [Configuration Cloning \(Backup Tab\)](#) section.

#### 6.13.4. System

##### Cleartext Login (Login Settings)

This cleartext login tool allows setting a password for login, thus the device will not accept any command coming from a control interface (RS-232, Ethernet, etc...) without login. The device will be visible in the Device Discovery window (as the device type and the serial number can be queried without login), but connection can only be established after a successful login. The login is valid until a TCP socket break in case of Ethernet connection. `#login`

**INFO:** The login password is erased and the login is disabled when restoring the factory default values.

##### Further functions

- **Download system log** - saving the file of the device.
- **Load factory defaults** - recalling factory default settings and values. All factory default settings are listed in the [Factory Default Settings](#) section.
- **Reboot** - rebooting the system. `#factory` `#systemlog` `#reboot` `#restart`

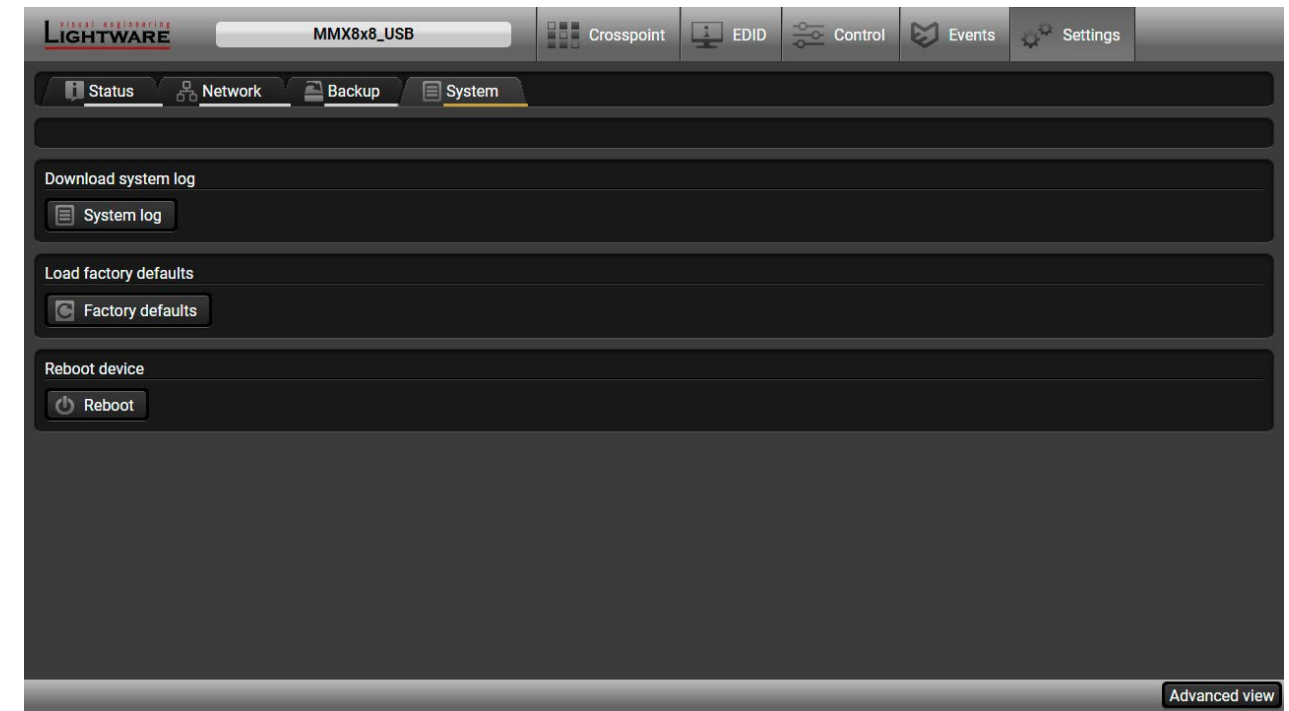

**System tab in the Settings menu**



## 6.14. Configuration Cloning (Backup Tab)

The configuration cloning of Lightware LW3 devices is a simple method that eliminates the need to repeatedly configure certain devices to have identical (non-factory) settings. If the devices are installed in the same type of system multiple times, then it is enough to set up only one device to fit the user's needs and then copy those settings to the others, thus saving time and resources. *#backup #configurationcloning*

**ATTENTION!** Macros cannot be saved into the backup file. If you have macros stored in a Configuration slot, download it separately and upload it into the target device.

Manage stored device configuration presets

Slot ID	Configuration Name	Protection
Slot 1	prezet	Protected
Slot 2	<Empty slot>	Not protected
Slot 3	<Empty slot>	Not protected

Backup tab in Settings menu

### 6.14.1. Cloning Steps in a Nutshell

Installing multiple devices with the same customized configuration settings can be done in a few easy steps:

- Step 1.** Configure one device with all your desired settings with the LDC software.
- Step 2.** Backup the full configuration file to your computer.
- Step 3.** If needed, make some modifications to the configuration file using a text editor (e.g. Notepad). E.g. modifying the static IP address is needed when DHCP is not used.
- Step 4.** Connect to the other device that needs to be configured and upload (restore) your configuration file.
- Step 5.** Done! You can have as many totally identical, customized devices as you like.

**ATTENTION!** Macros cannot be saved into the backup file. If you have macros stored in a Configuration slot, download it separately and upload it into the target device.

### 6.14.2. Save the Settings of the Device (Backup)

- Step 1.** Apply the desired settings in the transmitter (port parameters, crosspoint, etc.)
- Step 2.** Select the **Settings / Backup** tab from the menu.
- Step 3.** Write a short **description** in the text box on the left (optional).
- Step 4.** Press the **Create a full backup** button. You will be prompted to save the file to the computer. The default file name is the following:

```
BACKUP_<DEVICE TYPE>_SN<SERIAL NUMBER>.LW3
```

- Step 5.** Set the desired **file name**, select the folder and **save** the file.

**TIPS AND TRICKS:** Using the exact product type in the filename is recommended, since it makes the file usage more comfortable.

#### About the Backup File

The backup file is a simple text file, which contains LW3 protocol commands. The first line is the description, and the further lines are the commands that will be executed during the restoration process. The file can be viewed (and/or edited) by a simple text editor, e.g. Notepad.

**ATTENTION!** Editing the command lines is recommended for expert users only.

See the entire list of saved data in the [Content of the Backup File](#) section.

### 6.14.3. Upload the Settings to a Device (Restore)

**WARNING!** Please note that the settings will be permanently overwritten with the restored parameters in the device. Withdrawal is not possible.

**ATTENTION!** The cloning can be successful if the backup file is downloaded from the same type of source device as the destination device.

#### The Restoring Process

**Step 1.** Select the **Settings / Backup** tab from the menu.

**Step 2.** Click on the **Choose file** button on the right panel and **browse** the desired file.

**Step 3.** The file is checked and the result will be displayed in the textbox below. If the file is correct, the settings can be restored.

**Step 4.** Choose the **IP settings** that you want to use after backup. You can apply settings from the backup file, keep actual settings, set it manually in a dialog box, or apply DHCP.

**Step 5.** Select the desired **MAC filter settings** to be applied in the device. See more information about this feature in the [MAC Filter Allowlist](#) section.

**Step 6.** Press the **Start restore process** button and click on the **Yes** button when asked.

**Step 7.** Reboot the device to apply the network settings after finishing.

### 6.14.4. Create and Restore Backups from the Device Memory

The device can store configurations in its own memory, four slots are available for this purpose.

Slot ID	Configuration Name	Protection
Slot 1	Preset_0720	Not protected
Slot 2	backup_0125	Protected
Slot 3	<Empty slot>	Not protected
Slot 4	<Empty slot>	Not protected

Apply Save Save as protected Delete Upload Download

You can save the configuration to the desired slot:

- **without protection:** it can be easily applied/deleted, or
- **with protection:** applying or deleting the configuration can be protected by a password.

<b>Apply</b>	Loading the selected configuration	<b>Delete</b>	Deleting the selected configuration
<b>Save</b>	Saving the current configuration to the selected slot without protection	<b>Upload</b>	Loading a configuration from a file to the selected slot
<b>Save as protected</b>	Saving the current configuration to the selected slot with a password	<b>Download</b>	Saving the selected configuration as a file

The presets can be used for the macros as well, please see the [Macros](#) section.

**WARNING!** Loading factory default settings will erase all presets in the device memory!

## 6.15. The Built-in Miniweb

**DEFINITION:** The miniweb is a dedicated location in the memory where an HTML file can be uploaded to. If the `<IP_address>/index.html` page is opened in a web browser, the file is displayed.

**ATTENTION!** The Miniweb is available from firmware package v1.2.0. The default control page can be installed in the device during the first firmware upgrade process by the user if the necessary parameter is enabled. See the [Step 3 – Check the update parameters](#) section.

**INFO:** If the [Cleartext Login \(Login Settings\)](#) is active, you will be prompted to enter the password when opening the miniweb content.

The default control page allows the following: `#builtinweb` `#miniweb` `#web`

- **Source selection:** This block can be used to select an input or enable/disable the Autoselect remotely e.g. from a mobile device.
- **Action triggers:** The action trigger buttons can be used to perform a configured Event Action without waiting for the condition to occur. This can be done remotely by a mobile device, too.

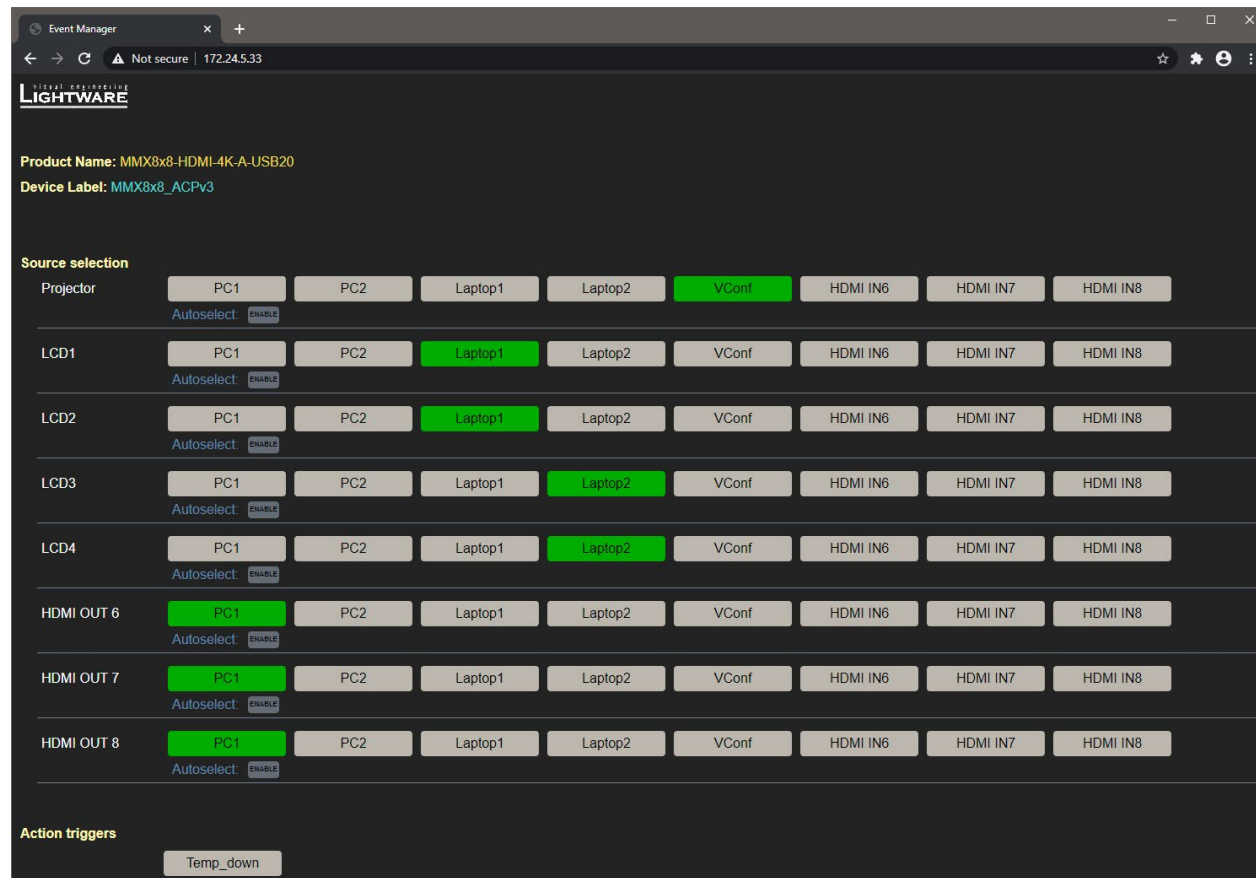

*The Control Page Displayed in a Desktop Browser*

### 6.15.1. Opening the Miniweb

The Miniweb is available by:

- Opening the **web browser** and typing the **IP address** or the **host name** of the desired device in the address line (see the [Setting the Host Name](#) section),
- Launching the **LDC**, connecting to the device, navigating to **Settings/Status** and pressing the **Open miniweb** button.

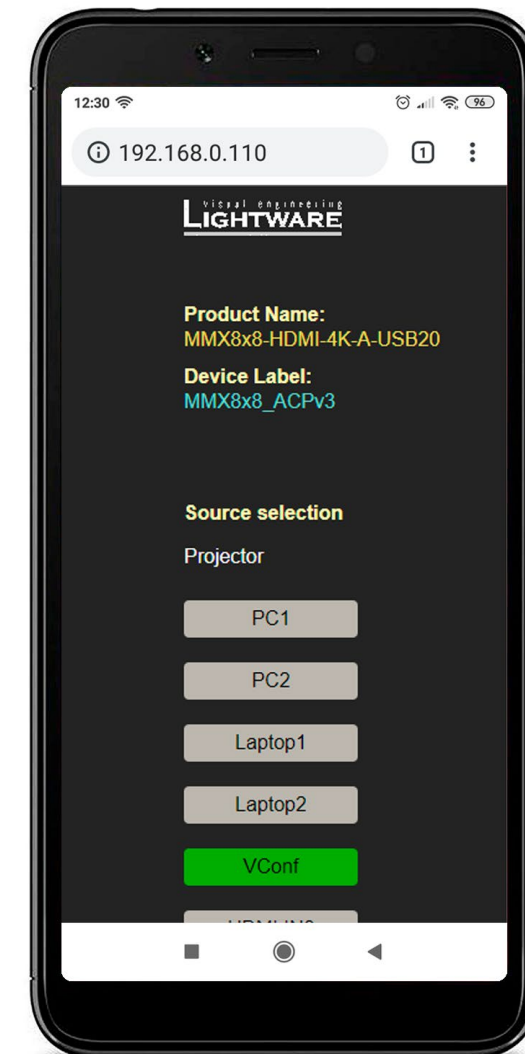

*The Control Page Displayed in a Smartphone Browser*

### 6.15.2. The Default Status Page

If there is no control page uploaded, the default status page will be displayed (which is also available by opening the <IP\_address>/status.html address). This page works without login as well.

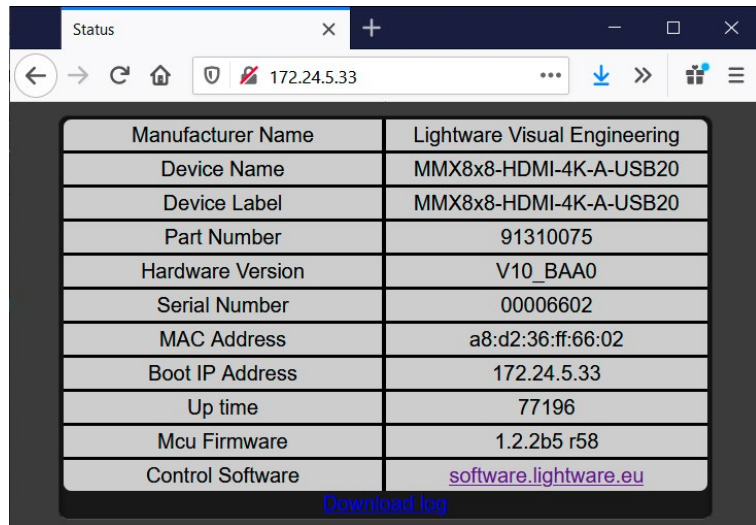

The Factory Default Status Page (status.html)

### 6.15.3. Miniweb Customization

The buttons of **Action triggers** section are linked to Actions of certain Events in the Event Manager. These buttons are displayed **only** for specific events:

- Any Event that does **not** have the @W suffix in its name will not be displayed as a trigger button.
- The displayed trigger buttons will get a **text label** with the **event name** except the suffix.

To add the desired Action as a button, **append the name** of the desired Event with the @W characters - see below (type uppercase for 'W', as it is case-sensitive):

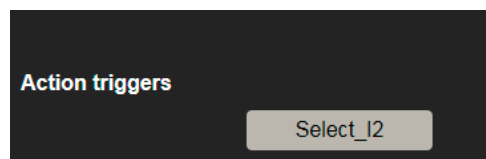
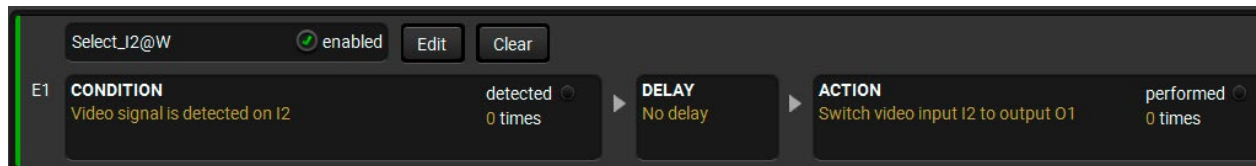

Action Trigger Button added in the Event Manager and displayed in the Control Page

### Customized HTML

The default control page can be replaced in the LDC; navigate to the **Settings/Status** page. Custom HTML file can be uploaded by pressing the **Choose file** button. Pay attention to the size of the HTML file. Only one file is allowed, and the maximum file size is 10 KB (in case of SW4-TPS-TX240-Plus it's 80 KB).

Press the **Reset** button to remove the control page. The default control page can be restored during a firmware upgrade process, see the [Step 3 – Check the update parameters](#) section.

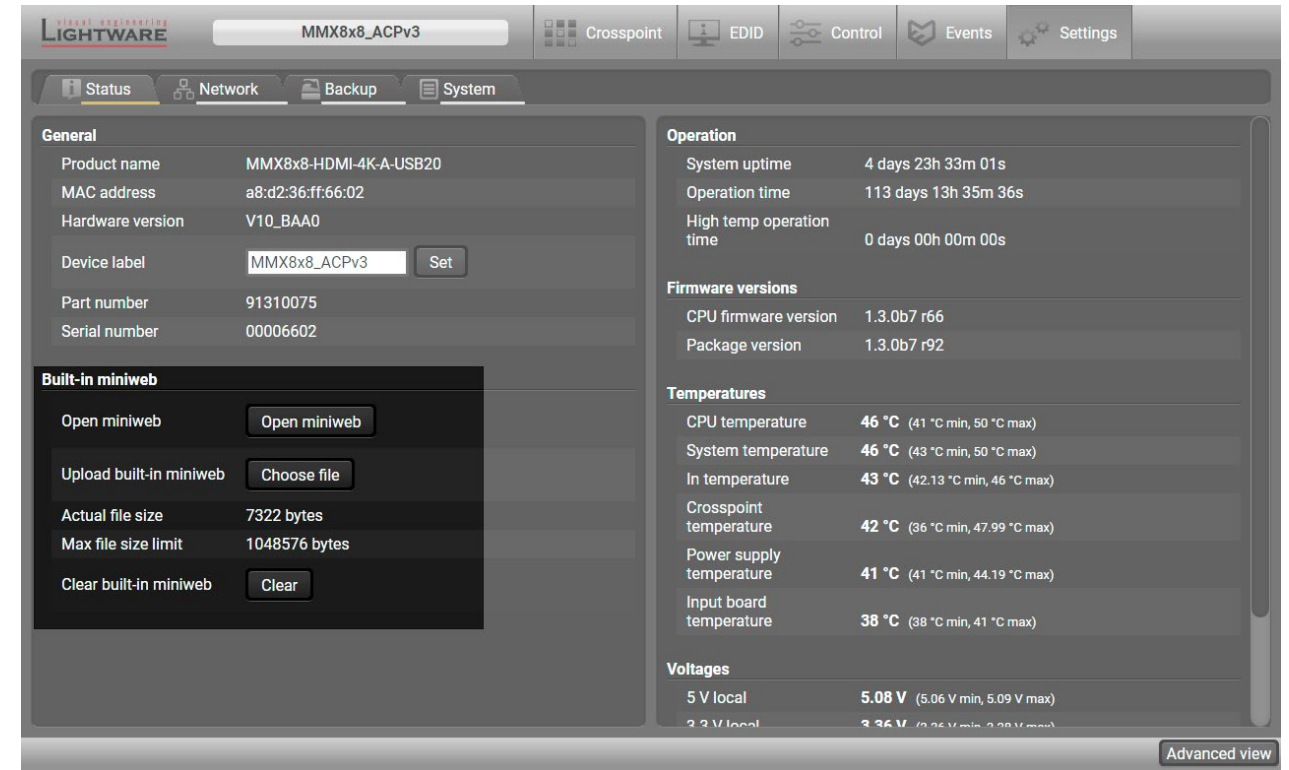

The Built-in Miniweb Section in LDC

## 6.16. Advanced View

Advanced view is the surface for displaying the LW3 protocol tree. Commands and specific parameters (that are not available on the graphical user interface of the LDC) can be run and set by the controlling tools.

The screenshot shows the LW3 protocol tree interface. It features a terminal window on the left (1) displaying protocol commands and responses. A central panel (2) shows a hierarchical tree structure with categories like MEDIA, VIDEO, and XP. A right panel (3) displays the selected node's parameters (e.g., SourcePortCount, DestinationPortCount) with input fields and 'Manual' buttons. At the top, there are checkboxes for 'Enable editing' (4) and 'Warn before enable editing' (6). A 'Send' button and 'Autoscroll' checkbox are at the bottom (7).

#advancedview #terminal

- 1 **LW3 Protocol Help** Short description about the command types and the LW3 Protocol.
- 2 **Terminal Window** Commands and responses. The sent command starts with ">" character, the received response starts with "<" character. The content of the window can be emptied by the **Clear** button. If the **Autoscroll** option is ticked, the list is scrolled automatically when a new line is added. Hover the mouse cursor over a line to display the date and time stamp in a Hint field.
- 3 **Protocol Tree** LW3 protocol tree; select an item to see its content.
- 4 **Edit Mode** The default appearance is the **Edit mode**. If the option is unticked, the values or parameters cannot be changed.
- 5 **Node List** Parameters and nodes of the selected item are shown. The commands typed in these fields are **escaped automatically**.
- 6 **Warn Option** The LDC can be set to warn the user before enabling the **Edit mode**.
- 7 **Command Line** The commands typed in this line are **not escaped automatically**.

# 7

## LW2 Programmers' Reference

Lightware's MMX8x8-HDMI family can be controlled with external devices that can communicate according to the extender protocol. The supported LW2 commands are described in this chapter.

- ▶ [PROTOCOL DESCRIPTION](#)
- ▶ [INSTRUCTIONS FOR THE TERMINAL APPLICATION USAGE](#)
- ▶ [GENERAL LW2 COMMANDS](#)
- ▶ [PORT AND CROSSPOINT SETTINGS](#)
- ▶ [NETWORK CONFIGURATION](#)
- ▶ [GPIO SETTINGS](#)
- ▶ [LW2 COMMANDS – QUICK SUMMARY](#)

## 7.1. Protocol Description

The protocol description hereinafter stands for Lightware protocol. The commands can be sent to the device in RAW format via the TCP/IP port no. 10001.

The receiver accepts commands surrounded by curly brackets - { } - and responds data surrounded by round brackets - ( ) - only if a command was successfully executed. All input commands are converted to uppercase, but response commands can contain upper and lower case letters as well.

### Legend for Control Commands

Format	Explanation
<in>	Input number in 1- or 2-digit ASCII format (01, 5, 07, 16, etc.)
<out>	Output number in 1- or 2-digit ASCII format
<in/out>	Input or output port number in 1- or 2-digit ASCII format *
<in2>	Input number in 2-digit ASCII format (01, 02, 10, 12 etc.)
<out2>	Output number in 2-digit ASCII format (01, 02, 10, 12 etc.)
<in2/out2>	Input or output number in 2-digit ASCII format*
<loc>	Location number in 1-, 2- or 3-digit ASCII format
<id>	ID number in 1- or 2-digit ASCII format
<id2>	ID number in 2-digit ASCII format
CrLf	Carriage return, Line feed (0x0D, 0x0A)
.	Space character (0x20)
→	Each command issued by the controller
←	Each response received from the router

\* The command has the same arguments on the input ports and the output port, as well.

## 7.2. Instructions for the Terminal Application Usage

### Terminal Application

The LW2 protocol commands can be applied to the receiver using a terminal application. You need to install one of them on your control device, for example **Putty** or **CLI**. *#terminal #new*

### Establishing Connection

Follow the steps to establish connection to the receiver:

- Step 1.** Connect the receiver to a LAN over Ethernet.
- Step 2.** Open the terminal application (e.g. Putty).
- Step 3.** Add the **IP address** of the device (default: 192.168.0.100) and the **port number (10001)**.
- Step 4.** Select the **Raw** connection type, and open the connection.

Once the terminal window is opened, you can enter the LW2 protocol commands, which are listed in the following sections.

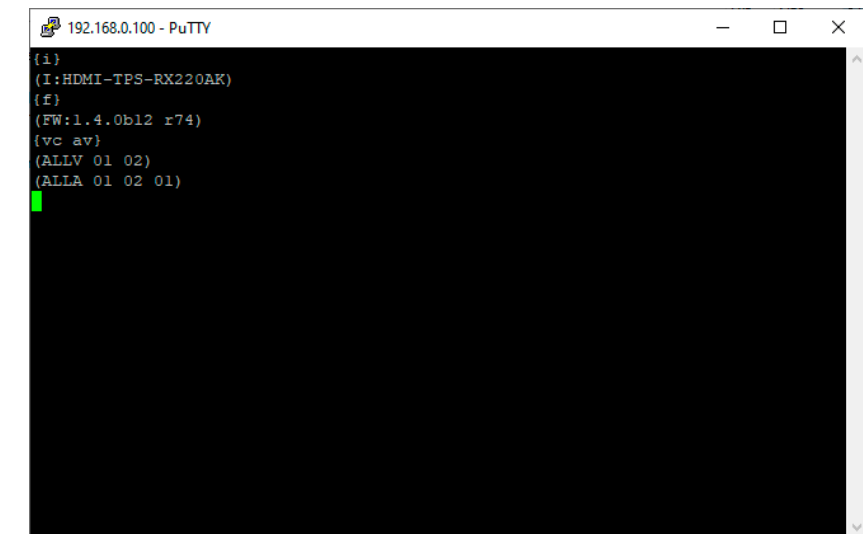
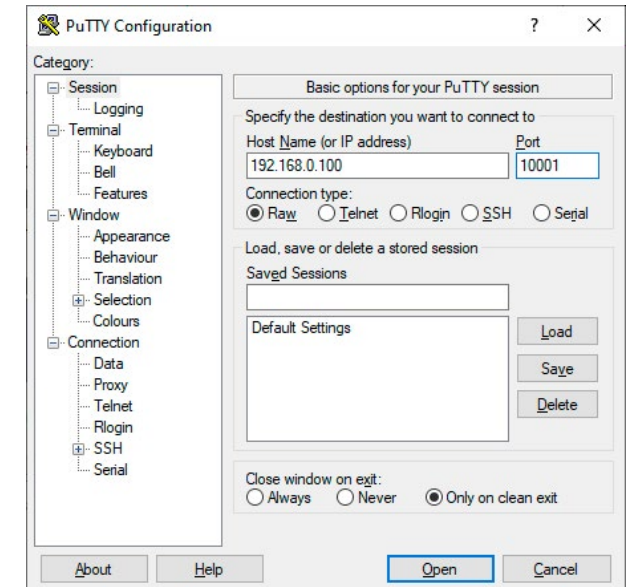

**LW2 protocol command communication in a terminal window**

## 7.3. General LW2 Commands

### 7.3.1. Querying the Supported Commands

The LW2 commands supported by the device can be queried by this command.

#### Command and Response *#producttype*

```
→ {LCMD}
← (LCMD# <command>: <description>)CrLf
← ...
← (LCMD END)CrLf
```

#### Example

```
→ {lcmd}
← (LCMD# [inputNum]@[outputNum] <A|V>: Switch)CrLf
← (LCMD# [inputNum]@O <A|V>: Switch to all)CrLf
← (LCMD# #[outputNum] <A|V>: Mute)CrLf
← ...
← (LCMD END)CrLf
```

INFO: The response is longer, not all lines can be seen in the example.

### 7.3.2. Viewing Product Type

The device responds its name.

#### Command and Response

```
→ {}
← (I:<PRODUCT_TYPE>)CrLf
```

#### Example

```
→ {}
← (I:MMX8x8-HDMI-4K-A)CrLf
```

### 7.3.3. Viewing Serial Number

The device responds its 8-digit serial number. *#serialnumber*

#### Command and Response

```
→ {S}
← (SN:<SERIAL_N>)CrLf
```

#### Example

```
→ {s}
← (SN:00005484)CrLf
```

### 7.3.4. Querying Device Label

The respond shows the device label, which is a read-only parameter in LW2, but it can be changed by an LW3 command, see the [Setting the Device Label](#) section.

#### Command and Response

```
→ {LABEL=?}
← (SN:<DEVICE_LABEL>)CrLf
```

#### Example

```
→ {LABEL=?}
← (LABEL=MTG_ROOM_2)CrLf
```

### 7.3.5. Querying Control Protocol

The device can be controlled with different control protocols. This command queries the active protocol of the currently used control interface.

#### Command and Response

```
→ {P_?}
← (CURRENT·PROTOCOL·=#<protocol>)CrLf
```

#### Example

```
→ {P_?}
← (CURRENT PROTOCOL = #1)CrLf
```

The device communicates with LW2 protocol.

### 7.3.6. Viewing Firmware Version of the Firmware Package

View the installed firmware package version. *#firmwareversion*

#### Command and Response

```
→ {f}
← (FW:<FW_VER>·<s>)CrLf
```

#### Parameters

<FW\_VER> is the firmware package version. It is followed by <s> string, which may indicate special versions.

#### Example

```
→ {f}
← (FW:1.0.0b15 r17)CrLf
```



### 7.3.7. Connection Test

Simple test to see if the connection is established successfully.

#### Command and Response

```
→ {PING}
← (PONG!)CrLf
```

#### Example

```
→ {ping}
← (PONG!)CrLf
```

### 7.3.8. Compile Time

Returns the date when the microcontroller firmware was compiled.

#### Command and Response

```
→ {CT}
← (Complied: <DATE&TIME>)CrLf
```

#### Example

```
→ {ct}
← (Complied: May 11 2016 11:01:27)CrLf
```

### 7.3.9. Viewing Installed Board(s)

Shows the hardware name and revision of the installed card(s).

#### Command and Response

```
→ {IS}
← (SL#0•0•<MB_DESC>)CrLf
← (SL•END)CrLf
```

#### Example

```
→ {is}
← (SL#0 Mmx8x8-Mb8)CrLf
← (SL#1 MMX8X8-CONN Right)CrLf
← (SL#2 MMX8X8-CONN Left)CrLf
← (SL#3 DCM-G3)CrLf
← (SL#4 MX-HDMI-3D-IB)CrLf
← (SL#5 MX-HDMI-3D-STEREO-ADDON)CrLf
← (SL#6 MX-HDMI-3D-STEREO-ADDON)CrLf
← (SL#7 MX-HDMI-3D-STEREO-ADDON)CrLf
← (SL#8 MX-HDMI-3D-OB)CrLf
← (SL#9 MX-CP)CrLf
← (SL END)CrLf
```

The device reports its motherboard (slot 0).

### 7.3.10. Viewing Firmware for all Controllers'

Shows the firmware package versions of all installed controllers.

#### Command and Response

```
→ {FC}
← (CF•<DESC>)CrLf
← (CF•<DESC>)CrLf
← ...
← (CF•END)CrLf
```

#### Parameters

<FW\_VER> is the firmware version. It is followed by <s> string, which may indicate special versions.

#### Example

```
→ {fc}
← (CF MMX8x8-HDMI-4K-A 1.3.3b2 r80)CrLf
← (CF END)CrLf
```

The device has one control panel. *#firmwareversion*

### 7.3.11. Restarting the Matrix Router

The device can be restarted without unplugging power. *#reboot #restart*

#### Command and Response

```
→ {RST}
←
```

#### Example

```
→ {rst}
←
```

The device reboots; no response is sent in this case.

### 7.3.12. Querying Health Status

Internal voltages and measured temperature values are shown.

#### Command and Response

```
→ {ST}
← (ST•<DESC>)CrLf
```

#### Example

```
→ {st}
← (ST CPU 5.14V 3.38V 57.29C 63.30C 63.00C 51.05C 62.74C 63.25C 58.44C)CrLf
```

### 7.3.13. Restoring Factory Default Settings

Settings can be reset to factory default values as follows: `#factory`

#### Command and Response

```
→ {FACTORY=ALL}
← (FACTORY ALL...)CrLf
```

#### Example

```
→ {factory=all}
← (FACTORY ALL...)CrLf
```

All settings and parameters are reset to factory default, see the table in the [Factory Default Settings](#) section.

## 7.4. Port and Crosspoint Settings

### 7.4.1. Switching One Input to One Output

Switching an input <in> to output <out>. The following commands with A, V, AV parameter value can take effect in multiple layers, according to their parameters. Depending on 'A' or 'V' it can change only the Audio or only the Video layer; 'AV' changes both. `#crosspoint` `#switch`

#### Command and Response

```
→ {<in>@<out>•<layer>}
← (O<out2>•I<in2>•<layer>)CrLf
```

#### Parameters

Identifier	Parameter description	Parameter values
<layer>	Signal type of the layer	<b>A:</b> audio layer <b>V:</b> video layer <b>AV:</b> audio & video layer
<out>	Output port	<b>01-08</b>
<in>	Input port	<b>I1-I8</b> <b>0:</b> Using the '0' (zero) value the input will be disconnected and no signal will appear on the output

INFO: The <layer> parameter usually can be skipped for legacy purposes. In this case, the devices change all (Video & Audio) layers, but using status commands it displays information about only the Video layer. Please use the AV option when available.

#### Example 1

```
→ {2@1 AV}
← (001 I02 AV)CrLf
```

I2 audio and I2 video input ports are switched to O1 output port.

#### Example 2

```
→ {0@1}
← (001 I00)CrLf
```

**ATTENTION!** The response of this command does not show whether the output is muted. To check the mute status, a separate query has to be used, like {VC}. See the [Viewing Connection State on the Output](#) section. To achieve multiple switches executed together, see the [Batch Switching Outputs](#) section.

### 7.4.2. Switching One Input to All Output

Switch input <in> to all outputs.

#### Command and Response

```
→ {<in>@0}
← (I<in2>•ALL)CrLf
```

#### Example

```
→ {2@0}
← (I02 ALL)CrLf
```

### 7.4.3. Muting Specified Output

Mute the <out> output. The output signal is turned off.

#### Command and Response `#mute` `#lock`

```
→ {#<out>•<layer>}
← (1MT<out2>•<layer>)CrLf
```

#### Example

```
→ {#01 A}
← (1MT01 A)CrLf
```

**ATTENTION!** Muting does not change the state of the crosspoint, but disables the output. Thus, the last connection can be easily restored by an unmute command. Switching a muted output does not unmute the output.

### 7.4.4. Unmuting Specified Output

Unmute the <out> output. `#unmute` `#unlock`

#### Command and Response

```
→ {+<out>•<layer>}
← (0MT<out2>•<layer>)CrLf
```

#### Example

```
→ {+01 V}
← (0MT01 V)CrLf
```

INFO: Unmuting an output makes the previous connection active, as the crosspoint state has not been changed by the muting command, only the output was disabled.

### 7.4.5. Locking the Output

Locking an output port. The output's state cannot be changed until unlocking.

#### Command and Response

```
→ {#><out>•<layer>}
← (1LO<out2>•<layer>)CrLf
```

#### Example

```
→ {#>01 A}
← (1L001 A)CrLf
```

### 7.4.6. Unlocking the Output

Unlocking an output port. The connection on the output can be changed.

#### Command and Response

```
→ {+<<out>•<layer>}
← (OLO<out2>•<layer>)CrLf
```

#### Example

```
→ {+<01 V}
← (OLO01 V)CrLf
```

O1 video output port is unlocked.

**INFO:** The device issues the response above regardless of the previous state of the output (whether it was locked or unlocked).

### 7.4.7. Viewing Connection State on the Output

Viewing the output's connection results in different response length, because it depends on the device. The response below refers to an MMX8x4-HT420M.

#### Command and Response #crosspoint #switch

```
→ {VC•<layer>}
← (ALL<layer>•<001>•<002>)CrLf
```

#### Parameters

O01 shows the corresponding output's connection state.

Identifier	Parameter description	Parameter values
<layer>	Signal type of the layer	<b>A:</b> audio layer <b>V:</b> video layer <b>AV:</b> audio & video layer

#### State letters

Letter	State	Example
L	Output is locked	L01
M	Output is muted	M01
U	Output is locked and muted	U01

#### Example

```
→ {VC AV}
← (ALLV M01 01)CrLf
← (ALLA 01 01)CrLf
```

I2 video input port is connected to the video output port and I5 audio input port is connected to the audio output port. AV is not used in the response. When AV is typed in the commands, the response will result in two lines, one for the Video and one for the Audio port states.

### 7.4.8. Viewing Crosspoint Size

Shows the physical crosspoint size.

#### Command and Response

```
→ {getsize•<layer>}
← (SIZE=<size>•<layer>)CrLf
```

#### Parameters

Identifier	Parameter description	Parameter values
<size>	Crosspoint size	<number_of_inputs>x<number_of_outputs>
<layer>	Signal type of the layer	See the previous section

#### Example

```
→ {GETSIZE }
← (SIZE=8x8)CrLf
```

### 7.4.9. Batch Switching Outputs

The device is capable of switching multiple outputs exactly at the same time. To do this, the normal switch commands have to be used. If the switch commands arrive at the device with less than 10 milliseconds delay, the commands are collected and the output connections change together.

#### Required circumstances:

- Switch commands have this format: {<in>@<out>}{<in>@<out>}
- The delay between two '}' characters must be less than 10 milliseconds
- No other command or junk character is allowed between switch commands
- Affected outputs must not be locked

If any of the above circumstances fail, then the commands will be processed separately and the output connections will change one by one.

**ATTENTION!** The delay timeout applies for the receiving time of characters. Please note that if LAN connection is used, then the network may cause additional delays. This could result in batch switching failing to occur. The example below shows a command that resulted in batch switching:

#### One by one commands

```
→ {02@01 V}
← (001 I02)CrLf
→ {05@04 V}
← (004 I05)CrLf
```

#### Batch commands

```
→ {02@01}{05@04}
← (001 I02)CrLf
← (004 I05)CrLf
```

## 7.5. Network Configuration

### 7.5.1. Querying the Current IP Status

IP address settings can be queried as follows. #dhcp #ipaddress #network

#### Command and Response

```
→ {IP_STAT=?}
← (IP_STAT=<type>;<ip_address>;<subnet_mask>;<gateway_addr>)CrLf
```

#### Parameters

Identifier	Parameter description	Parameter values
<type>	Assignment of the IP address	0: static 1: dynamic (DHCP)
<ip_addr>	IP address	(four decimal octets separated by dots)
<subnet_mask>	Subnet mask	(four decimal octets separated by dots)
<gateway_addr>	Gateway address	(four decimal octets separated by dots)

#### Example

```
→ {ip_stat=?}
← (IP_STAT=0;192.168.0.100;255.255.255.0;192.168.0.1)CrLf
```

The device has a static (fix) IP address: 192.168.0.100; the subnet mask is 255.255.255.0, the gateway address is 192.168.0.1.

### 7.5.2. Setting the IP Address

IP address can be set as follows.

#### Command and Response

```
→ {IP_ADDRESS=<type>;<ip_address>}
← (IP_ADDRESS=<type>;<ip_address>)CrLf
```

#### Parameters

See the previous section.

#### Example

```
→ {ip_address=0;192.168.0.110}
← (IP_ADDRESS=0;192.168.0.110)CrLf
```

**INFO:** The IP address can be queried by typing the "ip\_address=?" command. The response contains the fix IP address that is stored in the device even if DHCP is enabled; in this case, this IP address is not valid.

### 7.5.3. Setting the Subnet Mask

Subnet mask can be set as follows.

#### Command and Response

```
→ {IP_NETMASK=<subnet_mask>}
← (IP_NETMASK=<subnet_mask>)CrLf
```

#### Parameters

See the [Querying the Current IP Status](#) section.

#### Example

```
→ {ip_netmask=255.255.255.0}
← (IP_NETMASK=255.255.255.0)CrLf
```

INFO: The subnet mask can be queried by typing the “ip\_address=?” command. The response contains the fix IP subnet mask that is stored in the device even if DHCP is enabled; in this case, this IP subnet mask is not valid.

### 7.5.4. Setting the Gateway Address

Gateway address can be set as follows.

#### Command and Response

```
→ {IP_GATEWAY=<gateway_addr>}
← (IP_GATEWAY=<gateway_addr>)CrLf
```

#### Parameters

See the [Querying the Current IP Status](#) section.

#### Example

```
→ {ip_gateway=192.168.0.50}
← (IP_GATEWAY=192.168.0.50)CrLf
```

INFO: The gateway address can be queried by typing the “ip\_gateway=?” command. The response contains the static IP gateway address that is stored in the device even if DHCP is enabled. In that case, the latest valid gateway address (for static IP) is stored.

### 7.5.5. Applying Network Settings

Apply the network settings and restart the network interface.

#### Command and Response

```
→ {ip_apply}
← (IP_APPLY)CrLf
```

#### Example

```
→ {ip_apply}
← (IP_APPLY)CrLf
```

### 7.6. GPIO Settings

**DIFFERENCE:** This command is available in the MMX8x8-HDMI-4K-A-USB20 model.

#### 7.6.1. Setting the GPIO State

The GPIO state can be changed. *#gpio*

#### Command and Response

```
→ {GPIO<port_nr>=<direction>;<output_level>}
← (GPIO<port_nr>=<direction>;<output_level>)CrLf
```

#### Parameters

Identifier	Parameter description	Parameter values
<direction>	Direction of the signal	I: input O: output
<output_level>	Current level of the pin	H: high L: low

#### Example

```
→ {GPIO1=I;H}
← (GPIO1=I)CrLf
```

INFO: The GPIO state can be queried by typing the {GPIO<port\_nr>=?} command.

## 7.7. LW2 Commands – Quick Summary

### General LW2 Commands

#### Querying the Supported Commands

→ {LCMD}

#### Viewing Product Type

→ {i}

#### Viewing Serial Number

→ {S}

#### Querying Device Label

→ {LABEL=?}

#### Querying Control Protocol

→ {P\_?}

#### Viewing Firmware Version of the Firmware Package

→ {f}

#### Connection Test

→ {PING}

#### Compile Time

→ {CT}

#### Viewing Installed Board(s)

→ {IS}

#### Viewing Firmware for all Controllers'

→ {FC}

#### Restarting the Matrix Router

→ {RST}

#### Querying Health Status

→ {ST}

#### Restoring Factory Default Settings

→ {FACTORY=ALL}

### Port and Crosspoint Settings

#### Switching One Input to One Output

→ {<in>@<out>•<layer>}

#### Switching One Input to All Output

→ {<in>@0}

#### Muting Specified Output

→ {#<out>•<layer>}

#### Unmuting Specified Output

→ {+<out>•<layer>}

#### Locking the Output

→ {#><out>•<layer>}

#### Unlocking the Output

→ {+<<out>•<layer>}

#### Viewing Connection State on the Output

→ {VC•<layer>}

#### Viewing Crosspoint Size

→ {getsize•<layer>}

#### Batch Switching Outputs

### Network Configuration

#### Querying the Current IP Status

→ {IP\_STAT=?}

#### Setting the IP Address

→ {IP\_ADDRESS=<type>;<ip\_address>}

#### Setting the Subnet Mask

→ {IP\_NETMASK=<subnet\_mask>}

#### Setting the Gateway Address

→ {IP\_GATEWAY=<gateway\_addr>}

#### Applying Network Settings

→ {ip\_apply}

### GPIO Settings

#### Setting the GPIO State

→ {GPIO<port\_nr>=<direction>;<output\_level>}

# 8

## LW3 Programmers' Reference

The device can be controlled through Lightware 3 (LW3) protocol commands to ensure the compatibility with other Lightware products. The supported LW3 commands are described in this chapter.

- ▶ OVERVIEW
- ▶ INSTRUCTIONS FOR THE TERMINAL APPLICATION USAGE
- ▶ PROTOCOL RULES
- ▶ SYSTEM COMMANDS
- ▶ CLEARTEXT LOGIN PROTECTION
- ▶ SWITCHING AND CROSSPOINT SETTINGS
- ▶ VIDEO PORT SETTINGS
- ▶ EDID MANAGEMENT
- ▶ AUX ANALOG AUDIO I/O PORT SETTINGS
- ▶ SERIAL PORT CONFIGURATION
- ▶ SERIAL PORT MESSAGING
- ▶ RS-232 MESSAGE RECOGNIZER
- ▶ IR PORT CONFIGURATION
- ▶ IR PORT MESSAGING
- ▶ ETHERNET CONFIGURATION
- ▶ ETHERNET MESSAGE SENDING
- ▶ TCP MESSAGE RECOGNIZER
- ▶ HTTP MESSAGING
- ▶ CEC COMMAND SENDING
- ▶ EVENT MANAGER BASICS
- ▶ EVENT MANAGER TOOL KIT
- ▶ VARIABLE-MANAGEMENT
- ▶ ETHERNET TOOL KIT
- ▶ GPIO PORT SETTINGS
- ▶ USB PORT SETTINGS
- ▶ SYSTEM MONITORING COMMANDS
- ▶ LW3 QUICK SUMMARY

### 8.1. Overview

The Lightware Protocol #3 (LW3) is implemented in almost all new Lightware devices (matrix switchers, signal extenders and distribution amplifiers) since 2012. The protocol is ASCII-based and all commands are terminated with a carriage return (Cr, '\r') and line feed (Lf, '\n') pair. It is organized as a tree structure that provides outstanding flexibility and user-friendly handling with 'nodes', 'properties' and 'methods'. The **Advanced View** of the Lightware Device Controller software is the perfect tool for browsing and learning how the LW3 protocol can be used in practice.

### 8.2. Instructions for the Terminal Application Usage

#### Terminal Application

The LW3 protocol commands can be applied to the receiver using a terminal application. You need to install one of them on your control device, for example **Putty** or **CLI**. #terminal

#### Establishing Connection

Follow the steps to establish connection to the receiver:

- Step 1.** Connect the receiver to a LAN over Ethernet.
- Step 2.** Open the terminal application (e.g. Putty).
- Step 3.** Add the **IP address** of the device (default: 192.168.0.100) and the **port number (6107)**.
- Step 4.** Select the **Raw** connection type, and open the connection.

Once the terminal window is opened, you can enter the LW3 protocol commands, which are listed in the following sections.

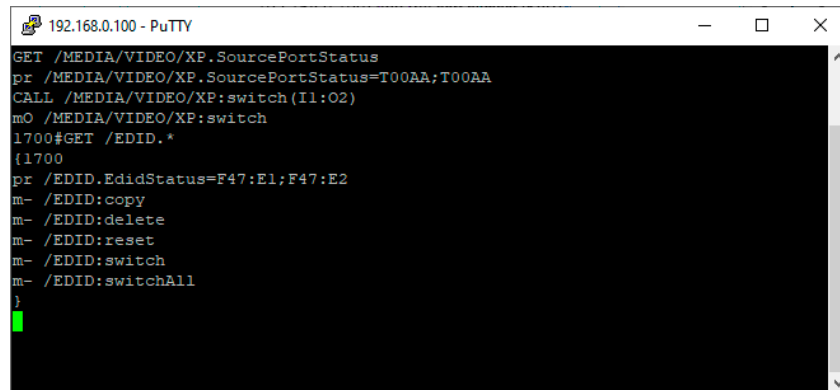
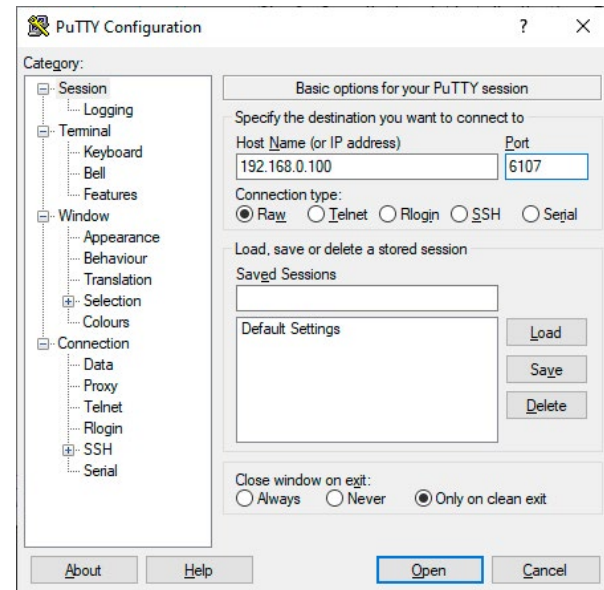

LW3 protocol command communication in a terminal window

### 8.3. Protocol Rules

#### 8.3.1. LW3 Tree Structure and Command Structure (examples)

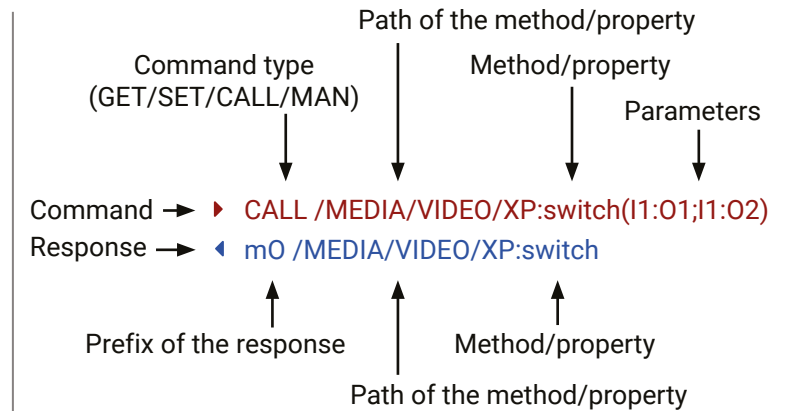
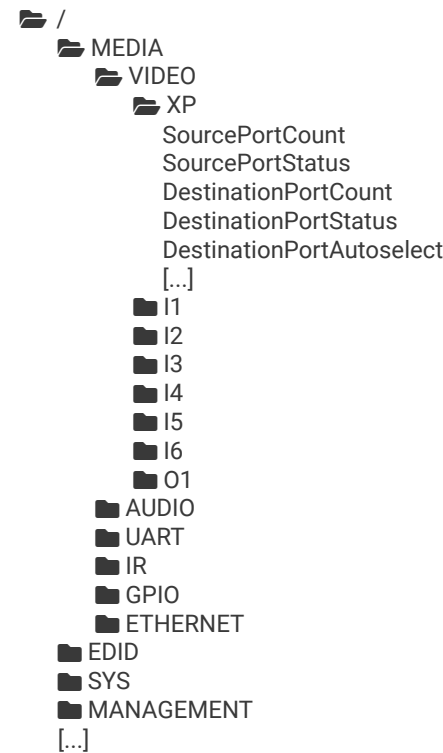

#### 8.3.2. General Rules

- All names and parameters are **case-sensitive**.
- The nodes are separated by a slash ('/') character.
- The node name can contain the elements of the English alphabet and numbers.
- The command lines have to be closed by Carriage return and Line Feed (CrLf).
- Use the **TCP port no. 6107** when using LW3 protocol over Ethernet.
- The length of a line (command/response, command type / prefix, path, method/property and parameters together) can be **max. 800 bytes**.
- When a command is issued by the device, the received response cannot be processed by the CPU.
- The node paths describe the exact location of the node, listing each parent node up to the root.



### 8.3.3. Command Types

#### GET command

The **GET** command can be used to get the child nodes, properties and methods of a specific node. It can also be used to get the value of a property. Use the dot character (.) when addressing a property:

- ▶ **GET /.SerialNumber**
- ◀ **pr /.SerialNumber=87654321**

#### GETALL command

The **GETALL** command can be used to get all child nodes, properties and methods of a node with one command.

- ▶ **GETALL /MEDIA/UART**
- ◀ **ns /MEDIA/UART/P1**
- ◀ **ns /MEDIA/UART/P2**
- ◀ **pr /MEDIA/UART.PortCount=2**
- ◀ **pr /MEDIA/UART.PortUi=P1:12209;P2:12224**
- ◀ **pr /MEDIA/UART.P1=Local RS-232**
- ◀ **pr /MEDIA/UART.P2=TPS out RS-232**

#### SET command

The **SET** command can be used to modify the value of a property. Use the dot character (.) when addressing the property:

- ▶ **SET /MEDIA/VIDEO/I1.ColorSpaceMode=0**
- ◀ **pw /MEDIA/VIDEO/I1.ColorSpaceMode=0**

#### CALL command

A method can be invoked by the **CALL** command. Use the colon character (:) when addressing the method:

- ▶ **CALL /MEDIA/VIDEO/XP:switch(I1:01)**
- ◀ **mO /MEDIA/VIDEO/XP:switch**

#### MAN command

The manual is a human readable text that describes the syntax and provides a hint on how to use the primitives. For every node, property and method in the tree there is a manual; type the MAN command to get the manual:

- ▶ **MAN /MEDIA/VIDEO/O1.Pwr5vMode**
- ◀ **pm /MEDIA/VIDEO/O1.Pwr5vMode ["0" | "1" | "2"] 0 - Auto, 1 - Always On, 2 - Always Off**

### 8.3.4. Prefix Summary

**DEFINITION:** The prefix is a 2-character-long code that describes the type of the response.

The following prefixes are defined in the LW3 protocol:

Prefix	Description
n-	a node
nE	an error for a node
nm	a manual for a node
pr	a read-only property
pw	read-write property
pE	an error for the property
pm	a manual for the property
m-	a method
mO	a response after a successful method execution
mF	a response after a failed method execution
mE	an error for a method
mm	a manual for a method

### 8.3.5. Error Messages

There are several error messages defined in the LW3 protocol, all of them have a unique error number.

- ▶ **CALL /MEDIA/VIDEO/XP:switch(IA:01)**
- ◀ **mE /MEDIA/VIDEO/XP:switch %E004:Invalid value**

### 8.3.6. Escaping

**DEFINITION:** An escape sequence is a sequence of characters that does not represent itself when used inside a character or string literal, but is translated into another character or a sequence of characters.

Property values and method parameters can contain characters that are used as control characters in the protocol. They must be escaped. The escape character is the backslash ('\'), and escaping means injecting a backslash before the character that should be escaped (like in C language).

Control characters are the following: \ { } # % ( ) \r \n \t

The **original** message: **CALL /MEDIA/UART/P1:sendMessage(Set(01))**

The **escaped** message: **CALL /MEDIA/UART/P1:sendMessage(Set\01\))**

### 8.3.7. Signature

**DEFINITION:** The signature is a four-digit-long hexadecimal value that can be optionally placed before every command to keep a command and the corresponding responses together as a group.

Each line is terminated with carriage return (Cr, '\r') and line feed (Lf, '\n') characters. In several cases the number of the lines in the response cannot be determined in advance, e.g. the client intends to receive the whole response and also wants to be sure that the received lines belong together and to the same command. In these cases, a special feature, the 'signature' can be used. The response to that particular command will also be preceded by the signature, and the corresponding lines will be between brackets:

```
▶ 1700#GET /EDID.*
◀ {1700
◀ pr /EDID.EdidStatus=F89:E1;D1:E2;D1:E3;D1:E4;F89:E5
◀ m- /EDID:copy
◀ m- /EDID:delete
◀ m- /EDID:reset
◀ m- /EDID:switch
◀ m- /EDID:switchAll
◀ }
```

**INFO:** The lines of the signature are also Cr and Lf terminated.

### 8.3.8. Subscription

**DEFINITION:** Subscription to a node means that the user will get a notification if a property of the node changes.

A user can subscribe to any node. These notifications are asynchronous messages and are useful to keep the client application up to date, without having to periodically poll the node to detect a changed property. When the user does not want to be informed about the changes anymore, he can simply unsubscribe from the node.

**ATTENTION!** The subscriptions are handled separately for connections. Hence, if the connection is terminated, all registered subscriptions are deleted. After reopening a connection all subscribe commands have to be sent in order to get the notifications of the changes on that connection.

#### Subscribe to a Node

```
▶ OPEN /MEDIA/VIDEO
◀ o- /MEDIA/VIDEO
```

#### Get the Active Subscriptions

```
▶ OPEN
◀ o- /MEDIA/VIDEO
◀ o- /EDID
◀ o- /DISCOVERY
```

#### Subscribe to Multiple Nodes

```
▶ OPEN /MEDIA/VIDEO/*
◀ o- /MEDIA/VIDEO/*
```

#### Unsubscribe from a Node

```
▶ CLOSE /MEDIA/VIDEO
◀ c- /MEDIA/VIDEO
```

#### Unsubscribe from Multiple Nodes

```
▶ CLOSE /MEDIA/VIDEO/*
◀ c- /MEDIA/VIDEO/*
```

### 8.3.9. Notifications about the Changes of the Properties

When the value of a property is changed and the user is subscribed to the node that the property belongs to, an asynchronous notification is generated. This notification is called the 'change message'. The format of such a message is very similar to the response for the GET command:

```
◀ CHG /EDID.EdidStatus=F48:E1
```

#### A Short Example of How to Use the Subscription

There are two independent users controlling the device through two independent connections (**Connection #1** and **Connection #2**). The events in the rows occur after each other.

```
▶ OPEN /MEDIA/AUDIO/O3
◀ o- /MEDIA/AUDIO/O3
▶ GET /MEDIA/AUDIO/O3.VolumePercent
◀ pw /MEDIA/AUDIO/O3.VolumePercent=100.00
▶ GET /MEDIA/AUDIO/O3.VolumePercent
◀ pw /MEDIA/AUDIO/O3.VolumePercent=100.00
▶ SET /MEDIA/AUDIO/O3.VolumePercent=50.00
◀ pw /MEDIA/AUDIO/O3.VolumePercent=50.00
◀ CHG /MEDIA/AUDIO/O3.VolumePercent=50.00
```

connection #1

connection #2

connection #1

The first user (**Connection #1**) set a subscription to a node. Later the other user (**Connection #2**) made a change, and thanks to the subscription, the first user got a notification about the change.

### 8.3.10. Legend for the Control Commands

Format	Description
<in>	Input port number
<out>	Output port number
<port>	Input or output port number
<loc>	Location number
<parameter>	Specific property, which is defined and described in the command
<expression>	Batched parameters: the underline means that more expressions or parameters can be placed by using a semicolon, e.g. <u>I2;I4;I5</u> or <u>F27:E1;F47:E2</u>
▶	Sent command
◀	Received response
.	Space character

## 8.4. System Commands

### 8.4.1. Querying the Product Name

The name of the product is a read-only parameter and cannot be modified.

#### Command and Response

- ▶ GET·/.ProductName
- ◀ pr·/.ProductName=<product\_name>

#### Example

- ▶ GET /.ProductName
- ◀ pr /.ProductName=MMX8x8-HDMI-4K-A

### 8.4.2. Querying the Device Label

#### Command and Response

- ▶ GET·/MANAGEMENT/UID/DeviceLabel=<custom\_name>
- ◀ pw·/MANAGEMENT/UID/DeviceLabel=<custom\_name>

#### Parameters

Identifier	Parameter values
<custom_name>	The Device Label can be 39 characters long and ASCII characters are allowed. Longer names will be truncated.

#### Example

- ▶ GET /MANAGEMENT/UID.DeviceLabel=MMX\_Control\_room
- ◀ pw /MANAGEMENT/UID.DeviceLabel=MMX\_Control\_room

### 8.4.3. Setting the Device Label

**ATTENTION!** The device label can be changed to a custom text, which is displayed in many windows of the LDC. This writable parameter is not the same as the ProductName parameter. The default format of the device label is the following: LW\_<product\_name>\_<serial\_no>.

#### Command and Response #devicelabel

- ▶ SET·/MANAGEMENT/UID/DeviceLabel=<custom\_name>
- ◀ pw·/MANAGEMENT/UID/DeviceLabel=<custom\_name>

#### Parameters

Identifier	Parameter values
<custom_name>	The Device Label can be 39 characters long and ASCII characters are allowed. Longer names will be truncated.

#### Example

- ▶ SET /MANAGEMENT/UID.DeviceLabel=MMX\_Control\_room
- ◀ pw /MANAGEMENT/UID.DeviceLabel=MMX\_Control\_room

### 8.4.4. Querying the Serial Number

#### Command and Response

- ▶ GET·/.SerialNumber
- ◀ pr·/.SerialNumber=<serial\_nr>

#### Example

- ▶ GET /.SerialNumber
- ◀ pr /.SerialNumber=00005484

### 8.4.5. Querying the Package Version

This command shows the installed **firmware package** version.

#### Command and Response

- ▶ GET·/MANAGEMENT/UID.PackageVersion
- ◀ pr·/MANAGEMENT/UID.PackageVersion=<package\_version>

#### Example

- ▶ GET /MANAGEMENT/UID.PackageVersion
- ◀ pr /MANAGEMENT/UID.PackageVersion=1.6.0b9 r61

### 8.4.6. Querying the CPU Firmware Version

#### Command and Response #firmwareversion

- ▶ GET·/SYS/MB.FirmwareVersion
- ◀ pr·/SYS/MB.FirmwareVersion=<firmware\_version>

#### Example

- ▶ GET /SYS/MB.FirmwareVersion
- ◀ pr /SYS/MB.FirmwareVersion=1.2.0b3

### 8.4.7. Identifying the Device

Calling the method results in the **Device identified!** message on the LCD screen. The feature helps identify the device itself in the rack shelf.

#### Command and Response

- ▶ CALL·/MANAGEMENT/UI:identifyMe()
- ◀ mO·/MANAGEMENT/UI:identifyMe

#### Example

- ▶ CALL /MANAGEMENT/UI:identifyMe()
- ◀ mO /MANAGEMENT/UI:identifyMe

### 8.4.8. Setting the Rotary Direction of the Jog Dial Knob

#### Command and Response

- ▶ SET·/MANAGEMENT/UI.RotaryDirection=<direction>
- ◀ pw·/MANAGEMENT/UI.RotaryDirection=<direction>

#### Parameters

Parameter	Parameter description	Values	Value description
<direction>	The rotary direction of the jog dial knob	0	The rotary direction is <b>clockwise</b>
		1	The rotary direction is <b>counterclockwise</b>

#### Example

- ▶ SET /MANAGEMENT/UI.RotaryDirection=0
- ◀ pw /MANAGEMENT/UI.RotaryDirection=0

### 8.4.9. Running a Macro

**DIFFERENCE:** This command is available from FW package v1.3.0.

**DEFINITION:** A macro is a batch of pre-defined commands stored in the device. *#macro*

You can create your custom macros in a file, upload it to the device and run at any time. The uploading can be done over LDC, see the [Macros](#) section. The following LW3 command is suitable only for running a macro.

#### Command and Response

- ▶ CALL·/CTRL/MACROS:run(<macro\_name>)
- ◀ mO·/CTRL/MACROS:run

#### Example

- ▶ CALL /CTRL/MACROS:run(Macro1)
- ◀ mO /CTRL/MACROS:run

### 8.4.10. Control Lock

Enable/disable the operation of the jog dial control knob. *#controllock*

#### Command and Response

- ▶ SET·/MANAGEMENT/UI.ControlLock=<control\_state>
- ◀ pw·/MANAGEMENT/UI.ControlLock=<control\_state>

#### Parameters

Parameter	Parameter description	Values	Value description
<control_state>	Locking state	0	The jog dial knob is <b>unlocked</b>
		1	The jog dial knob (and the buttons) are locked. In the MMX8x8-HDMI-4K-A model locked status can be changed with an LW3 protocol command or by pressing the Control Lock button for three seconds.
		2	Force locked: the jog dial knob (and the buttons) are locked and they can be unlocked only by an LW3 command.

#### Example

- ▶ SET /MANAGEMENT/UI.ControlLock=1
- ◀ pw /MANAGEMENT/UI.ControlLock=1

### 8.4.11. Resetting the Matrix

The matrix can be restarted – the current connections (LAN, RS-232) will be terminated.

#### Command and Response *#reset*

- ▶ CALL·/SYS:reset()
- ◀ mO·/SYS:reset=

#### Example

- ▶ CALL /SYS:reset()
- ◀ mO /SYS:reset=

### 8.4.12. Restoring the Factory Default Settings

#### Command and Response *#factorydefault*

- ▶ CALL·/SYS:factoryDefaults()
- ◀ mO·/SYS:factoryDefaults=

#### Example

- ▶ CALL /SYS:factoryDefaults()
- ◀ mO /SYS:factoryDefaults=

The device is restarted, current connections are terminated, and the default settings are restored. See the complete list in the [Factory Default Settings](#) section.

## 8.5. Cleartext Login Protection

**DIFFERENCE:** This feature and the commands below are available from firmware v1.3.0.

This cleartext login tool allows setting a password for login, thus any change in the device can be performed only after a successful login – coming from any control interface (RS-232, Ethernet, etc...). The login is valid until a TCP socket break in case of Ethernet connection. *#login*

**INFO:** The login password is erased and the login is disabled when restoring the factory default values.

The following can be queried without login:

- ProductName
- PartNumber
- SerialNumber
- FirmwareVersion
- PackageVersion
- MacAddress

### 8.5.1. Setting the Login Password

#### Command and Response

- ▶ CALL /LOGIN:setPassword(<password>)
- ◀ mO /LOGIN:setPassword

#### Example

- ▶ CALL /LOGIN:setPassword(pr0t3ctED)
- ◀ mO /LOGIN:setPassword

### 8.5.2. Logging into the Device

#### Command and Response

- ▶ CALL /LOGIN:login(<password>)
- ◀ mO /LOGIN:login

#### Example

- ▶ CALL /LOGIN:login(pr0t3ctED)
- ◀ mO /LOGIN:login

After a successful login, the **LoggedIn** property becomes **true** and the LW3 tree is available.

### 8.5.3. Logging out of the Device

#### Command and Response

- ▶ CALL /LOGIN:logout(<password>)
- ◀ mO /LOGIN:logout

#### Example

- ▶ CALL /LOGIN:logout(pr0t3ctED)
- ◀ mO /LOGIN:logout

After a successful logout, the **LoggedIn** property becomes **false** and the LW3 tree is protected.

### 8.5.4. Enabling/Disabling the Cleartext Login Function

**ATTENTION!** This property can be changed only if the **LoggedIn** property is **true**.

#### Command and Response

- ▶ SET /LOGIN:LoginEnable=<login\_state>
- ◀ pw /LOGIN.LoginEnable=<login\_state>

#### Parameters

If the <login\_state> parameter is **true** (or **1**), the Cleartext login function is **enabled**, if the parameter is **false** (or **0**), the function is **disabled**. Please note that the function can be enabled without setting a password by the **setPassword** method.

#### Example

- ▶ SET /LOGIN.LoginEnable=true
- ◀ pw /LOGIN.LoginEnable=true

## 8.6. Switching and Crosspoint Settings

### 8.6.1. Querying the Video Crosspoint State

#### Command and Response

- ▶ GET /MEDIA/VIDEO/XP:DestinationConnectionList
- ◀ pr /MEDIA/VIDEO/XP:DestinationConnectionList=<out1\_state>;<out2\_state>;<...>;<o5\_state>

#### Example

- ▶ GET /MEDIA/VIDEO/XP:DestinationConnectionList
- ◀ pr /MEDIA/VIDEO/XP:DestinationConnectionList=I1;I1;I8;I8;I1

I1 port is connected to O1,O2 and O5, I8 is connected to O3 and O4.

INFO: The response depends on the number of the output ports. The MMX8x8-HDMI-4K-A and the MMX8x8-HDMI-4K-A-USB20 models have 8 output ports.

### 8.6.2. Switching an Input to an Output

#### Command and Response *#crosspoint #switch*

- ▶ CALL /MEDIA/VIDEO/XP:switch(<in>:<out>)
- ◀ mO /MEDIA/VIDEO/XP:switch

#### Example 1

- ▶ CALL /MEDIA/VIDEO/XP:switch(I2:O1)
- ◀ mO /MEDIA/VIDEO/XP:switch

#### Example 2

- ▶ CALL /MEDIA/VIDEO/XP:switch(0:O1)
- ◀ mO /MEDIA/VIDEO/XP:switch

When using 0 (zero) value as an input, the input will be disconnected and no signal will appear on the output.

### 8.6.3. Switching an Input to All Outputs

#### Command and Response

- ▶ CALL /MEDIA/VIDEO/XP:switchAll(<in>)
- ◀ mO /MEDIA/VIDEO/XP:switchAll

#### Example

- ▶ CALL /MEDIA/VIDEO/XP:switchAll(I1)
- ◀ mO /MEDIA/VIDEO/XP:switchAll

TIPS AND TRICKS: All output ports can be disconnected by the '0' value:  
CALL /MEDIA/VIDEO/XP:switchAll(0).

## 8.7. Video Port Settings

### 8.7.1. Muting an Input Port

#### Command and Response *#mute*

- ▶ CALL /MEDIA/VIDEO/XP:muteSource(<in>)
- ◀ mO /MEDIA/VIDEO/XP:muteSource

#### Example

- ▶ CALL /MEDIA/VIDEO/XP:muteSource(I2)
- ◀ mO /MEDIA/VIDEO/XP:muteSource

### 8.7.2. Unmuting an Input Port

#### Command and Response *#unmute*

- ▶ CALL /MEDIA/VIDEO/XP:unmuteSource(<in>)
- ◀ mO /MEDIA/VIDEO/XP:unmuteSource

#### Example

- ▶ CALL /MEDIA/VIDEO/XP:unmuteSource(I2)
- ◀ mO /MEDIA/VIDEO/XP:unmuteSource

### 8.7.3. Muting an Output Port

#### Command and Response

- ▶ CALL /MEDIA/VIDEO/XP:muteDestination(<out>)
- ◀ mO /MEDIA/VIDEO/XP:muteDestination

#### Example

- ▶ CALL /MEDIA/VIDEO/XP:muteDestination(O1)
- ◀ mO /MEDIA/VIDEO/XP:muteDestination

### 8.7.4. Unmuting an Output Port

#### Command and Response

- ▶ CALL /MEDIA/VIDEO/XP:unmuteDestination(<out>)
- ◀ mO /MEDIA/VIDEO/XP:unmuteDestination

#### Example

- ▶ CALL /MEDIA/VIDEO/XP:unmuteDestination(O1)
- ◀ mO /MEDIA/VIDEO/XP:unmuteDestination

### 8.7.5. Locking an Input Port

#### Command and Response *#lock*

- ▶ CALL·/MEDIA/VIDEO/XP:lockSource(<in>)
- ◀ mO·/MEDIA/VIDEO/XP:lockSource

#### Example

- ▶ CALL /MEDIA/VIDEO/XP:lockSource(I1)
- ◀ mO /MEDIA/VIDEO/XP:lockSource

### 8.7.6. Unlocking an Input Port

#### Command and Response *#unlock*

- ▶ CALL·/MEDIA/VIDEO/XP:unlockSource(<in>)
- ◀ mO·/MEDIA/VIDEO/XP:unlockSource

#### Example

- ▶ CALL /MEDIA/VIDEO/XP:unlockSource(I1)
- ◀ mO /MEDIA/VIDEO/XP:unlockSource

### 8.7.7. Locking an Output Port

#### Command and Response

- ▶ CALL·/MEDIA/VIDEO/XP:lockDestination(<out>)
- ◀ mO·/MEDIA/VIDEO/XP:lockDestination

#### Example

- ▶ CALL /MEDIA/VIDEO/XP:lockDestination(O1)
- ◀ mO /MEDIA/VIDEO/XP:lockDestination

### 8.7.8. Unlocking an Output Port

#### Command and Response

- ▶ CALL·/MEDIA/VIDEO/XP:unlockDestination(<out>)
- ◀ mO·/MEDIA/VIDEO/XP:unlockDestination

#### Example

- ▶ CALL /MEDIA/VIDEO/XP:unlockDestination(O1)
- ◀ mO /MEDIA/VIDEO/XP:unlockDestination

### 8.7.9. Setting the HDCP (Input Port)

HDCP capability can be enabled/disabled on the input ports, thus non-encrypted content can be seen on a non-HDCP compliant display. See more information in the [HDCP Management](#) section.

#### Command and Response *#hdcp*

- ▶ SET·/MEDIA/VIDEO/<in>.HdcpEnable=<hdcp\_status>
- ◀ pw·/MEDIA/VIDEO/<in>.HdcpEnable=<hdcp\_status>

#### Parameters

Parameter	Parameter description	Values	Value description
<hdcp_status>	HDCP status	true	HDCP is enabled
		false	HDCP is disabled

#### Example

- ▶ SET /MEDIA/VIDEO/I1.HdcpEnable=false
- ◀ pw /MEDIA/VIDEO/I1.HdcpEnable=false

### 8.7.10. Setting the HDCP (Output Port)

HDCP capability can be set to Auto/Always on the output ports, thus non-encrypted content can be transmitted to a non-HDCP compliant display. See more information in the [HDCP Management](#) section.

#### Command and Response

- ▶ SET·/MEDIA/VIDEO/<out>.HdcpModeSetting=<hdcp\_mode>
- ◀ pw·/MEDIA/VIDEO/<out>.HdcpModeSetting=<hdcp\_mode>

#### Parameters

Parameter	Parameter description	Values	Value description
<hdcp_mode>	HDCP mode	0	Auto
		1	Always

#### Example

- ▶ SET /MEDIA/VIDEO/O1.HdcpModeSetting=0
- ◀ pw /MEDIA/VIDEO/O1.HdcpModeSetting=0

### 8.7.11. Querying the Connected Input Port Number

**DIFFERENCE:** This command is available from firmware v1.3.0.

The response of this command shows the input port that is connected to the queried output port.

#### Command and Response *#crosspoint*

- ▶ GET·/MEDIA/VIDEO/<out>.ConnectedSource
- ◀ pr·/MEDIA/VIDEO/<out>.ConnectedSource=<in>

#### Example

- ▶ GET /MEDIA/VIDEO/O1.ConnectedSource
- ◀ pr /MEDIA/VIDEO/O1.ConnectedSource=I1

### 8.7.12. Querying the Status of the Source Port

#### Command and Response #portstatus

- ▶ GET-/MEDIA/VIDEO/XP.SourcePortStatus
- ◀ pr-/MEDIA/VIDEO/XP.SourcePortStatus=<in1\_state>;<in2\_state>;<...>; <in#\_state>

#### Parameters

Identifier	Parameter values
<in#_state>	The responses contain one letter and a 1-byte-long HEX code showing the current state of the input ports. See the legend below.

#### Example

- ▶ GET /MEDIA/VIDEO/XP.SourcePortStatus
- ◀ pr /MEDIA/VIDEO/XP.SourcePortStatus=M00AA;L00AA;T00AA;T00AA;T00AA;T00AA;T00EF;T00AA

#### Legend

Letter (Character 1)		
	Mute state	Lock state
<b>T</b>	Unmuted	Unlocked
<b>L</b>	Unmuted	Locked
<b>M</b>	Muted	Unlocked
<b>U</b>	Muted	Locked

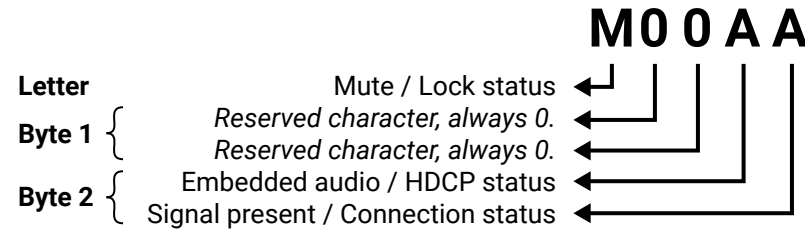

	Byte 1				Byte 2			
	Character 2		Character 3		Character 4		Character 5	
	BIT 7-6	BIT 5-4	BIT 3-2	BIT 1-0	BIT 7-6	BIT 5-4	BIT 3-2	BIT 1-0
	Reserved	Reserved	Reserved	Reserved	Embedded audio status	HDCP status	Signal present status	Connection status
<b>00</b>	Reserved	Reserved	Reserved	Reserved	Unknown			
<b>01</b>					Reserved			
<b>10</b>					No embedded audio	Not encrypted	No signal	Not connected
<b>11</b>					Embedded audio presents	Encrypted	Signal presents	Connected

#### Example and Explanation (M00AA):

T	0		0		A		A	
Unlocked, Unmuted	00	00	00	00	10	10	10	10
	Reserved	Reserved	Reserved	Reserved	No embedded audio	Not encrypted	No signal	Not connected

#### The Most Common Received Port Status Responses

T00AA	T	0		0		A		A	
Unlocked, Unmuted	00	00	00	00	00	10	10	10	10
	Reserved	Reserved	Reserved	Reserved	Reserved	No embedded audio	Not encrypted	No signal	Not connected

T00AB	T	0		0		A		B	
Unlocked, Unmuted	00	00	00	00	00	10	10	10	11
	Reserved	Reserved	Reserved	Reserved	Reserved	No embedded audio	Not encrypted	No signal	Connected

T00AF	T	0		0		A		F	
Unlocked, Unmuted	00	00	00	00	00	10	10	11	11
	Reserved	Reserved	Reserved	Reserved	Reserved	No embedded audio	Not encrypted	Signal presents	Connected

T00EF	T	0		0		E		F	
Unlocked, Unmuted	00	00	00	00	00	11	10	11	11
	Reserved	Reserved	Reserved	Reserved	Reserved	Embedded audio presents	Not encrypted	Signal presents	Connected

T00BF	T	0		0		B		F	
Unlocked, Unmuted	00	00	00	00	00	10	11	11	11
	Reserved	Reserved	Reserved	Reserved	Reserved	No embedded audio	Encrypted	Signal presents	Connected

T00FF	T	0		0		F		F	
Unlocked, Unmuted	00	00	00	00	00	11	11	11	11
	Reserved	Reserved	Reserved	Reserved	Reserved	Embedded audio presents	Encrypted	Signal presents	Connected



### 8.7.13. Querying the Status of the Destination Port

#### Command and Response

- ▶ GET /MEDIA/XP/VIDEO.DestinationPortStatus
- ◀ pr /MEDIA/XP/VIDEO.DestinationPortStatus=<out1\_state>;<out2\_state>;<...>;<out#\_state>

#### Parameters

Identifier	Parameter values
<out#_state>	The responses contain one letter and a 1-byte-long HEX code showing the current state of the output ports. See the Legend in the <a href="#">Querying the Status of the Source Port</a> section.

INFO: The response depends on the number of the output ports. The MMX8x8-HDMI-4K-A and the MMX8x8-HDMI-4K-A-USB20 models have 8 output ports.

#### Example

- ▶ GET /MEDIA/VIDEO/XP.DestinationPortStatus
- ◀ pr /MEDIA/VIDEO/XP.DestinationPortStatus=L00AA;T00AE;T00AF;T00AA;T00AB;T00AA;T00AA;T00AB

### 8.7.14. Querying the Video Autoselect Settings

#### Command and Response

- ▶ GET /MEDIA/VIDEO/XP.DestinationPortAutoselect
- ◀ pr /MEDIA/VIDEO/XP.DestinationPortAutoselect=<out1\_set>;<out2\_set>;<...>;<out#\_set>

The response shows the settings of each output one by one.

#### Parameters

Identifier	Parameter description		Parameter values
<out#_set>	Two-letter code of the Autoselect settings	1 <sup>st</sup> letter	<b>E</b> : Autoselect is enabled <b>D</b> : Autoselect is disabled
		2 <sup>nd</sup> letter	<b>F</b> : First detect mode: the first active video input is selected. <b>P</b> : Priority detect: it is always the highest priority active video input that will be selected. <b>L</b> : Last detect: it is always the last attached input that is automatically switched to the output.

#### Example

- ▶ GET /MEDIA/VIDEO/XP.DestinationPortAutoselect
- ◀ pr /MEDIA/VIDEO/XP.DestinationPortAutoselect=DP;EP;EF;DP;DP

DP: the autoselect is **D**isabled on output 1, output 4, and output 5.

EP: the Autoselect is **E**nabled on output 2 (selected mode is Priority detect).

EF: the Autoselect is **E**nabled on output 3 (selected mode is First detect).

INFO: For more information, see the [The Autoselect Feature](#) section.

### 8.7.15. Changing the Autoselect Mode

#### Command and Response #autoselect

- ▶ CALL /MEDIA/VIDEO/XP:setDestinationPortAutoselect(<out>;<out\_set>)
- ◀ m0 /MEDIA/VIDEO/XP:setDestinationPortAutoselect

#### Parameters

See the previous section.

#### Example

- ▶ CALL /MEDIA/VIDEO/XP:setDestinationPortAutoselect(O1:EF)
- ◀ m0 /MEDIA/VIDEO/XP:setDestinationPortAutoselect

The Autoselect mode is Enabled on Output 1 in First detect mode.

### 8.7.16. Querying the Input Port Priority

#### Command and Response

- ▶ GET /MEDIA/VIDEO/XP.PortPriorityList
- ◀ pr /MEDIA/VIDEO/XP.PortPriorityList=<out1\_list>;<out2\_list>;<...>;<out#\_list>

The response shows the priority of each output one after another. The priority number can be from 0 to 31; 0 is the highest and 30 is the lowest priority. 31 means that the port will be skipped from the priority list.

#### Parameters

Identifier	Parameter values
<out_list>	The input port priority order of the given output port: <in1>;<in2>;<...>;<in>

#### Example

- ▶ GET /MEDIA/VIDEO/XP.PortPriorityList
- ◀ pr /MEDIA/VIDEO/XP.PortPriorityList=7,6,5,4,3,2,1,0;0,1,2,3,4,5,6,7;0,1,2,3,4,5,6,7;0,1,2,3,4,5,6,7;0,1,2,3,4,5,6,7;0,1,2,3,4,5,6,7;0,1,2,3,4,5,6,7;0,1,2,3,4,5,6,7

There are eight outputs, so eight groups are listed in the response (divided by semicolons) and each group (list) contains eight priority numbers. The values show the priority order of the video input ports:

Output 1								Output 2								Output 3							
11	12	13	14	15	16	17	18	11	12	13	14	15	16	17	18	11	12	13	14	15	16	17	18
7	6	5	4	3	2	1	0	0	1	2	3	4	5	6	7	0	1	2	3	4	5	6	7
Output 3								Output 5								Output 6							
11	12	13	14	15	16	17	18	11	12	13	14	15	16	17	18	11	12	13	14	15	16	17	18
0	1	2	3	4	5	6	7	0	1	2	3	4	5	6	7	0	1	2	3	4	5	6	7
Output 7								Output 8															
11	12	13	14	15	16	17	18	11	12	13	14	15	16	17	18								
0	1	2	3	4	5	6	7	0	1	2	3	4	5	6	7								

Input 8 has the highest priority, Input 7 has the lowest priority on O1. On O2 O3, O4 and O5 ports the setting is the opposite.

**ATTENTION!** The same priority number can be set to different input ports. When the priority numbers match, the input port with the lowest port number will have the highest priority.

### 8.7.17. Changing the Input Port Priority

This method **requires** escaping the control characters. For more information, see the [Escaping](#) section. One or more inputs can be set at the same time.

#### Command and Response

- ▶ `CALL /MEDIA/VIDEO/XP:setAutoselectionPriority(<in>\(<out>\):<prio>);(<in>\(<out>\):<prio>)`
- ◀ `mO /MEDIA/VIDEO/XP:setAutoselectionPriority`

#### Parameters

The `<prio>` parameter is the priority number from 0 to 31. Equal numbers are allowed (31 means that the port will be skipped from the priority list). An input port priority can be set on an output port. Many settings can be executed by separating the with a semicolon (no space), see the example below.

#### Example

- ▶ `CALL /MEDIA/VIDEO/XP:setAutoselectionPriority(I1(O1):31;I2(O1):1;I3(O1):2;I4(O1):3;5(O1):4;I6(O1):5;I7(O1):6;I8(O1):7)`
- ◀ `mO /MEDIA/VIDEO/XP:setAutoselectionPriority`

The Input 1 is ignored from the autoselection, priority order of the inputs are: I2, I3, I4, I5, I6, I7, I8.

### 8.7.18. Setting the Signal Type (Output Ports)

#### Command and Response *#signaltype*

- ▶ `SET /MEDIA/VIDEO/<out>.HdmiModeSetting=<signal_type>`
- ◀ `pw /MEDIA/VIDEO/<out>.HdmiModeSetting=<signal_type>`

#### Example

- ▶ `SET /MEDIA/VIDEO/O1.HdcpModeSetting=1`
- ◀ `pw /MEDIA/VIDEO/O1.HdcpModeSetting=1`

#### Parameters

Identifier	Parameter description	Parameter values
<code>&lt;signal_type&gt;</code>	Signal type	0: Auto 1: DVI 2: HDMI

### 8.7.19. Test Pattern

The output ports can send a special image towards the sink devices for testing purposes. The setting is available on output ports with the parameters listed below.

**ATTENTION!** The Mode can be set individually on each port, but the Clock source and the Pattern settings are common on the O1-O2 and the O3-O4 output ports.

#### 8.7.19.1. Test pattern generator mode setting

##### Command and Response *#testpattern #nosyncscreen*

- ▶ `SET /MEDIA/VIDEO/<out>.TpgMode=<tpg_mode>`
- ◀ `pw /MEDIA/VIDEO/<out>.TpgMode=<tpg_mode>`

#### Parameters

Identifier	Parameter description	Parameter values
<code>&lt;tpg_mode&gt;</code>	Test pattern generator mode	0: Disabled - The test pattern is not displayed on the output. 1: Enabled - The test pattern is displayed on the output. 2: No signal mode - The test pattern is displayed if there is no signal on the output port.

#### Example

- ▶ `SET /MEDIA/VIDEO/O1.TpgMode=1`
- ◀ `pw /MEDIA/VIDEO/O1.TpgMode=1`

#### 8.7.19.2. Clock source – the clock frequency of the test pattern

##### Command and Response

- ▶ `SET /MEDIA/VIDEO/<out>.TpgClockSource=<tpg_clocksource>`
- ◀ `pw /MEDIA/VIDEO/<out>.TpgClockSource=<tpg_clocksource>`

#### Parameters

Identifier	Parameter description	Parameter values
<code>&lt;tpg_clocksource&gt;</code>	Clock frequency	480: 480p 576: 576p EXT: External clock (from current TMDS source)

#### Example

- ▶ `SET /MEDIA/VIDEO/O1.TpgClockSource=576`
- ◀ `pw /MEDIA/VIDEO/O1.TpgClockSource=576`

### 8.7.19.3. Test pattern

#### Command and Response

- ▶ SET-/MEDIA/VIDEO/<out>.TpgPattern=<pattern>
- ◀ pw-/MEDIA/VIDEO/<out>.TpgPattern=<pattern>

#### Parameters

Identifier	Parameter description	Parameter values
<pattern>	Selectable test image	RED / GREEN / BLUE / BLACK / WHITE / RAMP / CHESS / BAR / CYCLE

Cycle setting means all the patterns are changed sequentially approx. every 2 seconds.

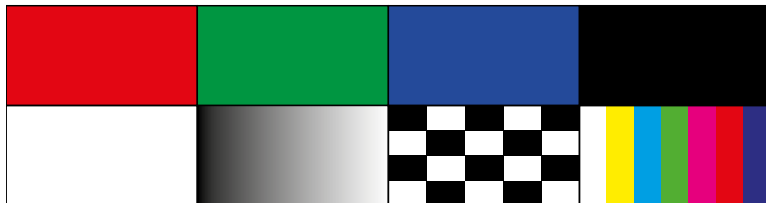

#### Example

- ▶ SET /MEDIA/VIDEO/O3.TpgPattern=BLUE
- ◀ pw /MEDIA/VIDEO/O3.TpgPattern=BLUE

## 8.8. EDID Management

### 8.8.1. Querying the Emulated EDIDs

It displays the emulated EDID memory place for each input port (I1-I8).

#### Command and Response

- ▶ GET-/EDID.EdidStatus
- ◀ pr-/EDID.EdidStatus=<source>:E1;<source>:E2;<...>;<source>:E8

#### Parameters

Identifier	Parameter description	Parameter values
<source>	Source EDID memory place	F#: Factory (F1-149) U#: User (U1- U24) D#: Dynamic (D1-D8)

#### Example

- ▶ GET /EDID.EdidStatus
- ◀ pr /EDID.EdidStatus=F149:E1;F47:E2;F47:E3;F47:E4;F47:E5;F47:E6;F47:E7;F47:E8

All emulated EDID memories (inputs) are listed with the EDID number that is currently emulated on the input, separated by semicolons. The example above shows that F149 EDID (149th Factory EDID) is emulated on I1 (E1) port, and F47 is emulated on all other input ports.

### 8.8.2. Setting the Emulated EDID

#### Command and Response #edid

- ▶ CALL-/EDID:switch(<source>:<destination>)
- ◀ mO-/EDID:switch

#### Parameters

Identifier	Parameter description	Parameter values
<source>	Source EDID memory place	F#: Factory (F1-149) U#: User (U1- U24) D#: Dynamic (D1-D8)
<destination>	The emulated EDID memory of the desired input port.	E#: Emulated (E1-E8)

#### Example

- ▶ CALL /EDID:switch(F149:E2)
- ◀ mO /EDID:switch

### 8.8.3. Copying an EDID into Another Slot

**ATTENTION!** The (User) EDID memory slot will be overwritten without notification even if it was not empty.

#### Command and Response

- ▶ CALL-/EDID:copy(<source>:<destination>)
- ◀ mO-/EDID:copy

#### Parameters

Identifier	Parameter description	Parameter values
<source>	Source EDID memory place	F#: Factory (F1-149) U#: User (U1- U24) D#: Dynamic (D1-D8)
<destination>	The desired User EDID memory slot	U#: User (U1- U24)

Many copy operations can be performed at the same time by using semicolons (see **Example2**).

#### Example1:

- ▶ CALL /EDID:copy(D2:U2)
- ◀ mO /EDID:copy

#### Example2:

- ▶ CALL /EDID:copy(D2:U5;D3:U6)
- ◀ mO /EDID:copy

## 8.9. AUX Analog Audio I/O Port Settings

INFO: Analog audio input/output setting commands are available in the MMX8x8-HDMI-4K-A model (I2, I4, I6 and I8 audio ports).

### 8.9.1. Setting the Audio Mode

**Command and Response** *#analogaudio*

- ▶ SET·/MEDIA/AUDIO/<in>.AudioMode=<audio\_mode>
- ◀ pw·/MEDIA/AUDIO/<in>.AudioMode=<audio\_mode>

**Parameters**

Identifier	Parameter description	Parameter values
<audio_mode>	Audio mode	0: HDMI audio passthrough 1: Embed from aux audio 2: De-embed to aux audio

**Example**

- ▶ SET /MEDIA/AUDIO/I6.AudioMode=1
- ◀ pw /MEDIA/AUDIO/I6.AudioMode=1

For more details, see the [General Audio Settings from Inputs to Outputs](#) in the [Audio Interface](#) section.

### 8.9.2. Muting/Unmuting the AUX Analog Audio Input

**Command and Response** *#mute*

- ▶ SET·/MEDIA/AUDIO/<in>/ADCVOLUME.Mute=<mute\_status>
- ◀ pw·/MEDIA/AUDIO/<in>/ADCVOLUME.Mute=<mute\_status>

**Parameters**

Parameter	Parameter description	Values	Value description
<mute_status>	Mute status	true	Muted
		false	Unmuted

**Example**

- ▶ SET /MEDIA/AUDIO/I6/ADCVOLUME.Mute=true
- ◀ pw /MEDIA/AUDIO/I6/ADCVOLUME.Mute=true

### 8.9.3. Setting the AUX Analog Audio Input Volume

This command sets the volume in dB scale. *#volume*

**Command and Response**

- ▶ SET·/MEDIA/AUDIO/<in>/ADCVOLUME.VoluedB=<volume\_dB>
- ◀ pw·/MEDIA/AUDIO/<in>/ADCVOLUME.VoluedB=<volume\_dB>

**Parameters**

Identifier	Parameter values
<volume_dB>	Volume can be set between -48.18dB and 0.00dB.

**Example**

- ▶ SET /MEDIA/AUDIO/I6/ADCVOLUME.VoluedB=-1
- ◀ pw /MEDIA/AUDIO/I6/ADCVOLUME.VoluedB=-1

### 8.9.4. Setting the AUX Analog Audio Input Balance

**Command and Response** *#balance*

- ▶ SET·/MEDIA/AUDIO/<in>/ADCVOLUME.Balance=<balance\_value>
- ◀ pw·/MEDIA/AUDIO/<in>/ADCVOLUME.Balance=<balance\_value>

**Parameters**

Identifier	Parameter values
<balance_value>	The balance value can be set between -100 (left) and +100 (right). Zero balance means the center setting.

**Example**

- ▶ SET /MEDIA/AUDIO/I6/ADCVOLUME.Balance=100
- ◀ pw /MEDIA/AUDIO/I6/ADCVOLUME.Balance=100

### 8.9.5. Setting the AUX Analog Audio Input Gain

This command sets the input gain in dB scale.

**Parameters**

Identifier	Parameter values
<gain_dB>	The gain can be set between 0.00dB and 24.00dB.

**Command and Response**

- ▶ SET·/MEDIA/AUDIO/<in>/ADCVOLUME.Gain=<gain\_dB>
- ◀ pw·/MEDIA/AUDIO/<in>/ADCVOLUME.Gain=<gain\_dB>

**Example**

- ▶ SET /MEDIA/AUDIO/I6/ADCVOLUME.Gain=1.00
- ◀ pw /MEDIA/AUDIO/I6/ADCVOLUME.Gain=1.00

### 8.9.6. Muting/Unmuting the AUX Analog Audio Output

**Command and Response** *#mute #analogaudio*

- ▶ SET·/MEDIA/AUDIO/<in>.DACVOLUME.Mute=<mute\_status>
- ◀ pw·/MEDIA/AUDIO/<in>.DACVOLUME.Mute=<mute\_status>

**Parameters**

Parameter	Parameter description	Values	Value description
<mute_status>	Mute status	true	Muted
		false	Unmuted

**Example**

- ▶ SET /MEDIA/AUDIO/I6/DACVOLUME.Mute=true
- ◀ pw /MEDIA/AUDIO/I6/DACVOLUME.Mute=true

### 8.9.7. Setting the AUX Analog Audio Output Volume

This command sets the volume in dB scale. *#volume*

**Command and Response**

- ▶ SET·/MEDIA/AUDIO/<in>/DACVOLUME.VoluedB=<volume\_dB>
- ◀ pw·/MEDIA/AUDIO/<in>/DACVOLUME.VoluedB=<volume\_dB>

**Example**

- ▶ SET /MEDIA/AUDIO/I6/DACVOLUME.VoluedB=-1
- ◀ pw /MEDIA/AUDIO/I6/DACVOLUME.VoluedB=-1

**Parameters**

Identifier	Parameter values
<volume_dB>	Volume can be set between -95.62dB and 0.00dB.

### 8.9.8. Setting the AUX Analog Audio Output Balance

**Command and Response** *#balance*

- ▶ SET·/MEDIA/AUDIO/<in>/DACVOLUME.Balance=<balance\_value>
- ◀ pw·/MEDIA/AUDIO/<in>/DACVOLUME.Balance=<balance\_value>

**Example**

- ▶ SET /MEDIA/AUDIO/I6/DACVOLUME.Balance=-100
- ◀ pw /MEDIA/AUDIO/I6/DACVOLUME.Balance=-100

**Parameters**

Identifier	Parameter values
<balance_value>	The balance value can be set between -100 (left) and +100 (right). Zero balance means the center setting.

## 8.10. Serial Port Configuration

**ATTENTION!** MMX8x8 series handles many serial ports. The following parameters can be set individually on each port; the exact port numbering is listed in the [Port Numbering](#) section.

### 8.10.1. Setting the Protocol

**Command and Response** *#protocol*

- ▶ SET·/MEDIA/UART/<serial\_port>.ControlProtocol=<cont\_protocol>
- ◀ pw·/MEDIA/UART/<serial\_port>.ControlProtocol=<cont\_protocol>

**Parameters**

Identifier	Parameter description	Parameter values
<serial_port>	Serial port number	P1-P10*
<cont_protocol>	Selected protocol	0: LW2 1: LW3

\*The number of the ports depends on the model type. The exact port numbering is listed in the [Port Numbering](#) section.

**Example**

- ▶ SET /MEDIA/UART/P1.ControlProtocol=1
- ◀ pw /MEDIA/UART/P1.ControlProtocol=1

### 8.10.2. Setting the BAUD Rate

**Command and Response** *#rs-232 #rs232*

- ▶ SET·/MEDIA/UART/<serial\_port>.Baudrate=<baudrate>
- ◀ pw·/MEDIA/UART/<serial\_port>.Baudrate=<baudrate>

**Parameters**

Identifier	Parameter description	Parameter values
<serial_port>	Serial port number	P1-P10*
<baudrate>	Baud rate value	0: 4800; 1: 7200; 2: 9600 3: 14400; 4: 19200; 5: 38400 6: 57600; 7: 115200

\*The number of the ports depends on the model type. The exact port numbering is listed in the [Port Numbering](#) section.

**Example**

- ▶ SET /MEDIA/UART/P1.Baudrate=2
- ◀ pw /MEDIA/UART/P1.Baudrate=2

### 8.10.3. Setting the Operation Mode

#### Command and Response

- ▶ SET /MEDIA/UART/<serial\_port>.Rs232Mode=<rs232\_mode>
- ◀ pw /MEDIA/UART/<serial\_port>.Rs232Mode=<rs232\_mode>

#### Parameters

Identifier	Parameter description	Parameter values
<serial_port>	Serial port number	P1-P10*
<rs232_mode>	RS-232 operation mode	0: Disconnect 1: Control 2: Command injection

\*The number of the ports depends on the model type. The exact port numbering is listed in the [Port Numbering](#) section.

#### Example

- ▶ SET /MEDIA/UART/P2.Rs232Mode=1
- ◀ pw /MEDIA/UART/P2.Rs232Mode=1

### 8.10.4. Enabling/Disabling the Command Injection Mode

#### Command and Response *#commandinjection*

- ▶ SET /MEDIA/UART/<serial\_port>.CommandInjectionEnable=<ci\_stat>
- ◀ pw /MEDIA/UART/<serial\_port>.CommandInjectionEnable=<ci\_stat>

#### Parameters

Identifier	Parameter description	Parameter values
<serial_port>	Serial port number	P1-P10*
<ci_stat>	Command injection status	<b>true</b> : Command injection enable <b>false</b> : Command injection disable

\*The number of the ports depends on the model type. The exact port numbering is listed in the [Port Numbering](#) section.

#### Example

- ▶ SET /MEDIA/UART/P2.CommandInjectionEnable=true
- ◀ pw /MEDIA/UART/P2.CommandInjectionEnable=true

**ATTENTION!** The Command injection status is stored in another read-only property, which is **True** if both properties mentioned above are set to the proper state; if so, Command injection mode is active: /MEDIA/UART/<serial\_port>.CommandInjectionStatus.

**ATTENTION!** Do not forget to set the TCP/IP port setting, which is individual for each RS-232 port and is stored in the /MEDIA/UART/<serial\_port>.CommandInjectionPort parameter.

### 8.10.5. Querying the RS-232 Command Injection Port Number

#### Command and Response

- ▶ GET /MEDIA/UART/<serial\_port>.CommandInjectionPort
- ◀ pw /MEDIA/UART/<serial\_port>.CommandInjectionPort

#### Example

- ▶ GET /MEDIA/UART/P1.CommandInjectionPort
- ◀ pw /MEDIA/UART/P1.CommandInjectionPort=8001

## 8.11. Serial Port Messaging

### 8.11.1. Sending a Message (ASCII-format) via RS-232

The command is for sending a command message in ASCII-format. This method **allows** escaping the control and non-printable characters. For more information, see the [Escaping](#) section. *#message*

#### Command and Response

- ▶ CALL /MEDIA/UART/P1:sendMessage(<message>)
- ◀ mO /MEDIA/UART/P1:sendMessage

#### Example

- ▶ CALL /MEDIA/UART/P1:sendMessage(PWR0)
- ◀ mO /MEDIA/UART/P1:sendMessage

The 'PWR0' message is sent out via the P1 serial port.

### 8.11.2. Sending a Text (ASCII-format) via RS-232

The command is for sending a command message in ASCII-format. This method **does not allow** sending a message with control and non-printable characters.

#### Command and Response

- ▶ CALL /MEDIA/UART/P1:sendText(<message>)
- ◀ mO /MEDIA/UART/P1:sendText

#### Example

- ▶ CALL /MEDIA/UART/P1:sendText(open)
- ◀ mO /MEDIA/UART/P1:sendText

The 'open' text is sent out via the P1 serial port.

### 8.11.3. Sending a Binary Message (HEX-format) via RS-232

The command is for sending a command message in Hexadecimal-format. This method **does not require** escaping the control characters.

#### Command and Response

- ▶ `CALL /MEDIA/UART/P1:sendBinaryMessage(<message>)`
- ◀ `mO /MEDIA/UART/P1:sendBinaryMessage`

#### Example

- ▶ `CALL /MEDIA/UART/P1:sendBinaryMessage(433030)`
- ◀ `mO /MEDIA/UART/P1:sendBinaryMessage`

The '433030' message is sent out via the P1 serial port.

### 8.11.4. Using Hexadecimal Codes

Hexadecimal codes can be inserted in the ASCII message when using:

**sendMessage command:** `CALL /MEDIA/UART/P1:sendMessage(C00\x0D)`

**tcpMessage command:** `CALL /MEDIA/ETHERNET:tcpMessage(C00\x0D)`

**udpMessage command:** `CALL /MEDIA/ETHERNET:udpMessage(C00\x0D)`

- `C00`: the message.
- `\x`: indicates that the following is a hexadecimal code.
- `0D`: the hexadecimal code (Carriage Return).

### 8.12. RS-232 Message Recognizer

This tool can be used to recognize messages coming from the RS-232 port. The message can be used as a Condition in Event manager and an Action can be defined for it.

#### Working Method

A message gets recognized from the incoming data if one of the following occurs:

- The set `DelimiterHex` is detected in the message, or
- The set `TimeOut` has passed since receiving the last data bit.

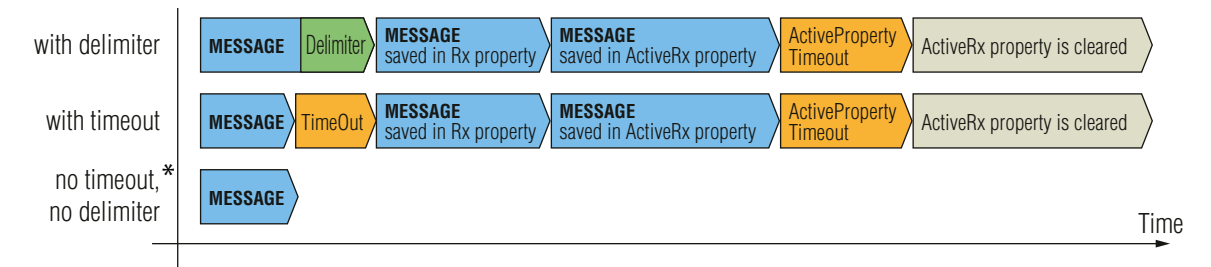

\* In that case the not-recognized data is kept in the memory (up to 128 bytes). If the `DelimiterHex` is detected later, or the `TimeOut` parameter is set in the meantime, the data appears in the `Rx`, `RxHex`, `Hash` and `ActiveRx`, `ActiveRxHex`, `ActiveRxHash` properties.

#### 8.12.1. Enabling/Disabling the Recognizer

##### Command and Response

- ▶ `SET /MEDIA/UART/<serial_port>.RecognizerEnable=<recognizer_enable>`
- ◀ `pw /MEDIA/UART/<serial_port>.RecognizerEnable=<recognizer_enable>`

##### Parameters

Parameter	Parameter description	Values	Value description
<serial_port>	Serial port number	<b>P1, P2</b>	
<recognizer_enable>	Recognizer mode	<b>true</b>	Recognizer is enabled
		<b>false</b>	Recognizer is disabled

##### Example

- ▶ `SET /MEDIA/UART/P1.RecognizerEnable=true`
- ◀ `pw /MEDIA/UART/P1.RecognizerEnable=true`

`#recognizer`    `#rs232recognizer`    `#rs-232recognizer`

### 8.12.2. Setting the Delimiter Hex

This property stores the delimiter that is between the messages (e.g. Cr, Lf, Space). The value has to be in hex format (e.g.0D, 0A, 20).

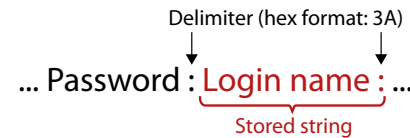

#### Command and Response

- ▶ SET /MEDIA/UART/RECOGNIZER.DelimiterHex=<delimiter>
- ◀ pw /MEDIA/UART/RECOGNIZER.DelimiterHex=<delimiter>

#### Parameters

Identifier	Parameter values
<delimiter>	It can be max. 8 characters long (or 16 hex digits) in hex format.

#### Example

- ▶ SET /MEDIA/UART/RECOGNIZER.DelimiterHex=3a
- ◀ pw /MEDIA/UART/RECOGNIZER.DelimiterHex=3a

### 8.12.3. Setting the Timeout

When the set time has passed after the last received message and delimiter was not detected, the device saves the data into the Rx, RxHex, Hash properties. The timeout setting is useful if there is no special or easily defined delimiter in the incoming data, but there is a time gap between the messages.

#### Command and Response

- ▶ SET /MEDIA/UART/RECOGNIZER.TimeOut=<timeout>
- ◀ pw /MEDIA/UART/RECOGNIZER.TimeOut=<timeout>

#### Parameters

The <timeout> parameter sets the timeout value in milliseconds: 0 means the timeout is disabled, min. value is 10.

#### Example

- ▶ SET /MEDIA/UART/RECOGNIZER.TimeOut=20
- ◀ pw /MEDIA/UART/RECOGNIZER.TimeOut=20

### 8.12.4. Querying the Last Recognized Message (String)

The recognized message is stored as a string in the property below until the next recognized message or until the **RECOGNIZER.clear()** method is called.

**TIPS AND TRICKS:** When this property is set as a condition in the Event Manager and the same strings follow each other, the action **will execute once**. (A Condition can be detected in Event Manager if a change happens. But if the same string is saved into the property after each other, it will not cause a change.)

#### Command and Response

- ▶ GET /MEDIA/UART/RECOGNIZER.Rx
- ◀ pr /MEDIA/UART/RECOGNIZER.Rx=<recognized\_string>

#### Parameters

Identifier	Parameter values
<recognized_string>	It can be a max. 12-byte-long recognized data string.

#### Example

- ▶ GET /MEDIA/UART/RECOGNIZER.Rx
- ◀ pr /MEDIA/UART/RECOGNIZER.Rx=Login:

### 8.12.5. Querying the Last Recognized Message(Hex)

#### Command and Response

- ▶ GET /MEDIA/UART/RECOGNIZER.RxHex
- ◀ pr /MEDIA/UART/RECOGNIZER.RxHex=<recognized\_hex>

#### Parameters

Identifier	Parameter values
<recognized_hex>	It is the recognized data in hex format.

#### Example

- ▶ GET /MEDIA/UART/RECOGNIZER.RxHex
- ◀ pr /MEDIA/UART/RECOGNIZER.RxHex=FF1F4C6F67696E3A

### 8.12.6. Clearing the Last Recognized Stored Message

This method deletes all stored received serial messages.

#### Command and Response

- ▶ CALL /MEDIA/UART/RECOGNIZER:clear()
- ◀ m0 /MEDIA/UART/RECOGNIZER:clear

#### Example

- ▶ CALL /MEDIA/UART/RECOGNIZER:clear()
- ◀ m0 /MEDIA/UART/RECOGNIZER:clear



### 8.12.7. Querying the Last Recognized Active Message (String)

The recognized data is stored in string in the property below **temporarily**. When the time set in the **ActiveTimeout** property has passed, the property is cleared.

**TIPS AND TRICKS:** When this property is set as a condition in the Event Manager and the same strings follow each other, the action **will execute on every occasion**. (A Condition can be detected in Event Manager if a change happens. In this case, the string is stored in the property and after the **ActiveTimeout** it will be cleared. If the same string is saved into the (empty) property, it will cause a change.)

#### Command and Response

- ▶ GET·/MEDIA/UART/RECOGNIZER.ActiveRx
- ◀ pr·/MEDIA/UART/RECOGNIZER.ActiveRx=<recognized\_string>

#### Parameters

Identifier	Parameter values
<recognized_string>	It can be a max. 12-byte-long recognized data string.

#### Example

- ▶ GET /MEDIA/UART/RECOGNIZER.ActiveRx
- ◀ pr /MEDIA/UART/RECOGNIZER.ActiveRx=Login:

### 8.12.8. Querying the Last Recognized Active Message (Hex)

#### Command and Response

- ▶ GET·/MEDIA/UART/RECOGNIZER.ActiveRxHex
- ◀ pr·/MEDIA/UART/RECOGNIZER.ActiveRxHex=<recognized\_hex>

#### Parameters

Identifier	Parameter values
<recognized_hex>	It is the recognized data in <b>hex</b> format.

#### Example

- ▶ GET /MEDIA/UART/RECOGNIZER.ActiveRxHex
- ◀ pr /MEDIA/UART/RECOGNIZER.ActiveRxHex= 4C6F67696E3A

### 8.12.9. Setting the Active Timeout

This property is responsible for clearing the **ActiveRx**, **ActiveRxHex**, **ActiveHash** properties after the elapsed time. Default value is 50ms.

#### Command and Response

- ▶ SET·/MEDIA/UART/RECOGNIZER.ActivePropertyTimeout=<a\_timeout>
- ◀ pw·/MEDIA/UART/RECOGNIZER.ActivePropertyTimeout=<a\_timeout>

#### Parameters

Identifier	Parameter values
<a_timeout>	It is the active timeout value (ms) between 0 and 255.

#### Example

- ▶ SET /MEDIA/UART/RECOGNIZER.ActivePropertyTimeout=255
- ◀ pw /MEDIA/UART/RECOGNIZER.ActivePropertyTimeout=255

### 8.12.10. Running an Immediate Event Action

**DIFFERENCE:** This command is available from firmware v1.6.0.

When a message is recognized (DelimiterHex is detected in the message, or TimeOut has passed since receiving the last data bit), a specific Action of an Event can be run by the following command.

#### Command and Response

- ▶ SET·/MEDIA/UART/RECOGNIZER.ActionTrigger=<event\_nr>
- ◀ pw·/MEDIA/UART/RECOGNIZER.ActionTrigger=<event\_nr>

#### Parameters

Identifier	Parameter values
<event_nr>	It means the number (location) of the linked Event Action without the letter 'E'. (There is no need to define a Condition in the linked Event.)

#### Example

- ▶ SET /MEDIA/UART/RECOGNIZER.ActionTrigger=5
- ◀ pw /MEDIA/UART/RECOGNIZER.ActionTrigger=5





#### 8.15.4. Setting a Static IP Address

##### Command and Response

- ▶ SET /MANAGEMENT/NETWORK.StaticIpAddress=<IP\_address>
- ◀ pw /MANAGEMENT/NETWORK.StaticIpAddress=<IP\_address>

##### Example

- ▶ SET /MANAGEMENT/NETWORK.StaticIpAddress=192.168.0.105
- ◀ pw /MANAGEMENT/NETWORK.StaticIpAddress=192.168.0.105

#### 8.15.5. Changing the Subnet Mask (Static)

##### Command and Response

- ▶ SET /MANAGEMENT/NETWORK.StaticNetworkMask=<netmask>
- ◀ pw /MANAGEMENT/NETWORK.StaticNetworkMask=<netmask>

##### Example

- ▶ SET /MANAGEMENT/NETWORK.StaticNetworkMask=255.255.255.0
- ◀ pw /MANAGEMENT/NETWORK.StaticNetworkMask=255.255.255.0

#### 8.15.6. Changing the Gateway Address (Static)

##### Command and Response

- ▶ SET /MANAGEMENT/NETWORK.StaticGatewayAddress=<gw\_address>
- ◀ pw /MANAGEMENT/NETWORK.StaticGatewayAddress=<gw\_address>

##### Example

- ▶ SET /MANAGEMENT/NETWORK.StaticGatewayAddress=192.168.0.5
- ◀ pw /MANAGEMENT/NETWORK.StaticGatewayAddress=192.168.0.5

#### 8.15.7. Applying Network Settings

■ INFO: All network settings are executed after calling this function.

##### Command and Response

- ▶ CALL /MANAGEMENT/NETWORK:ApplySettings(1)
- ◀ mO /MANAGEMENT/NETWORK:ApplySettings

##### Example

- ▶ CALL /MANAGEMENT/NETWORK:ApplySettings(1)
- ◀ mO /MANAGEMENT/NETWORK:ApplySettings

#### 8.16. Ethernet Message Sending

The device can be used for sending a message to a certain IP:port address. The three different commands allow controlling the connected (third-party) devices. #message

##### 8.16.1. Sending a TCP Message (ASCII-format)

The command is for sending a command message in ASCII-format. This method allows escaping the control characters. For more information, see the [Escaping](#) section.

##### Command and Response

- ▶ CALL /MEDIA/ETHERNET:tcpMessage(<IP\_address>:<port\_no>=<message>)
- ◀ mO /MEDIA/ETHERNET:tcpMessage

##### Example

- ▶ CALL /MEDIA/ETHERNET:tcpMessage(192.168.0.103:6107=C00)
- ◀ mO /MEDIA/ETHERNET:tcpMessage

The 'C00' message is sent to the indicated IP:port address.

##### Example with HEX codes

- ▶ CALL /MEDIA/ETHERNET:tcpMessage(192.168.0.20:5555=C00\x0a\x0d)
- ◀ mO /MEDIA/ETHERNET:tcpMessage

The 'C00' message with CrLf (Carriage return and Line feed) is sent to the indicated IP:port address. The \x sequence indicates the HEXA code; see more information in the [Using Hexadecimal Codes](#) section.

##### 8.16.2. Sending a TCP Text (ASCII-format)

The command is for sending a text message in ASCII-format. This method **does not allow** escaping or inserting control characters.

##### Command and Response

- ▶ CALL /MEDIA/ETHERNET:tcpText(<IP\_address>:<port\_no>=<text>)
- ◀ mO /MEDIA/ETHERNET:tcpText

##### Example

- ▶ CALL /MEDIA/ETHERNET:tcpText(192.168.0.103:6107=pwr\_on)
- ◀ mO /MEDIA/ETHERNET:tcpText

The 'pwr\_on' text is sent to the indicated IP:port address.

### 8.16.3. Sending a TCP Binary Message (HEX-format)

The command is for sending a binary message in Hexadecimal format. This method **does not require** escaping or inserting control characters.

#### Command and Response

- ▶ CALL /MEDIA/ETHERNET:tcpBinary(<IP\_address>:<port\_no>=<HEX\_message>)
- ◀ mO /MEDIA/ETHERNET:tcpBinary

#### Example

- ▶ CALL /MEDIA/ETHERNET:tcpBinary(192.168.0.103:6107=0100000061620000cdcc2c40)
- ◀ mO /MEDIA/ETHERNET:tcpBinary

The '0100000061620000cdcc2c40' message is sent to the indicated IP:port address.

■ INFO: There is no need to insert a space or other separator character between the binary messages.

### 8.16.4. Sending UDP Message (ASCII-format)

The command is for sending a UDP message in ASCII-format. This method allows escaping the control characters. For more information, see the [Escaping](#) section.

#### Command and Response

- ▶ CALL /MEDIA/ETHERNET:udpMessage(<IP\_address>:<port\_no>=<message>)
- ◀ mO /MEDIA/ETHERNET:udpMessage

#### Example

- ▶ CALL /MEDIA/ETHERNET:udpMessage(192.168.0.103:6107=C00)
- ◀ mO /MEDIA/ETHERNET:udpMessage

The 'C00' message is sent to the indicated IP:port address.

#### Example with HEX codes

- ▶ CALL /MEDIA/ETHERNET:udpMessage(192.168.0.20:9988=C00\x0a\x0d)
- ◀ mO /MEDIA/ETHERNET:udpMessage

The 'C00' message with CrLf (Carriage return and Line feed) is sent to the indicated IP:port address. The \x sequence indicates the HEXA code; see more information in the [Using Hexadecimal Codes](#) section.

### 8.16.5. Sending a UDP Text (ASCII-format)

The command is for sending a text message in ASCII-format via UDP-protocol. This method **does not allow** escaping or inserting control characters. *#message*

#### Command and Response

- ▶ CALL /MEDIA/ETHERNET:udpText(<IP\_address>:<port\_no>=<text>)
- ◀ mO /MEDIA/ETHERNET:udpText

#### Example

- ▶ CALL /MEDIA/ETHERNET:udpText(192.168.0.20:9988=open)
- ◀ mO /MEDIA/ETHERNET:udpText

The 'open' text is sent to the indicated IP:port address.

### 8.16.6. Sending a UDP Binary Message (HEX-format)

The command is for sending a binary message in Hexadecimal format via UDP protocol. This method **does not require** escaping or inserting control characters.

#### Command and Response

- ▶ CALL /MEDIA/ETHERNET:udpBinary(<IP\_address>:<port\_no>=<HEX\_message>)
- ◀ mO /MEDIA/ETHERNET:udpBinary

#### Example

- ▶ CALL /MEDIA/ETHERNET:udpBinary(192.168.0.20:9988=433030)
- ◀ mO /MEDIA/ETHERNET:udpBinary

The '433030' message is sent to the indicated IP:port address.

■ INFO: There is no need to insert a space or other separator character between the binary messages.

## 8.17. TCP Message Recognizer

**DIFFERENCE:** This feature and commands below are available from FW package v1.3.0.

This tool can be used to recognize messages coming from a TCP server. You can link an immediate event Action that is run when a message is recognized, but you can also use it in Event manager.

#tcprecognizer #message

### Preparation

- Step 1.** Set a TCP client in the Lightware device (three TCP clients can be run at the same time), set the properties of the target TCP server.
- Step 2.** Set the **DelimiterHex** and the **TimeOut** settings for the proper message processing
- Step 3.** Make sure the TCP/IP port is opened in the target device (think about Firewall settings in the network).
- Step 4.** Connect to the TCP server.

### Working Method

A message got recognized from the incoming data if one of the following occurs:

- The set **DelimiterHex** is detected in the message, or
- The set **TimeOut** has passed since receiving the last data bit.

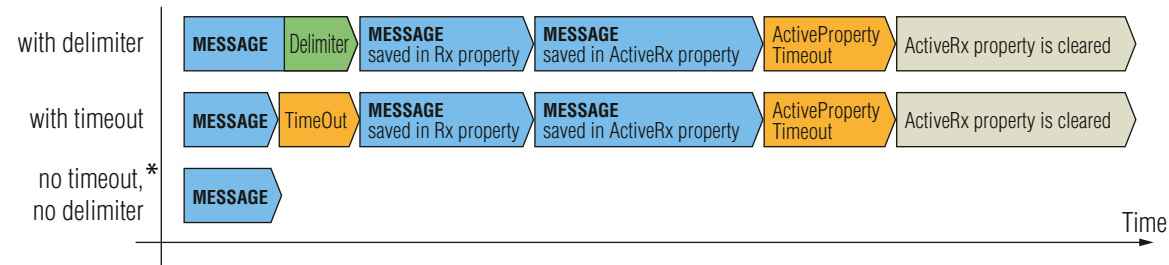

\* In that case the not-recognized data is kept in the memory (up to 128 bytes). If the **DelimiterHex** is detected later, or the **TimeOut** parameter is set in the meantime, the data appears in the **Rx**, **RxHex**, **Hash** and **ActiveRx**, **ActiveRxHex**, **ActiveRxHash** properties.

### 8.17.1. Setting the IP Address of the TCP Server

#### Command and Response

- ▶ SET /CTRL/TCP/C<loc>.ServerIP(<IP\_address>)
- ◀ pw /CTRL/TCP/C<loc>.ServerIP(<IP\_address>)

#### Parameters

The <loc> parameter can be 1, 2 or 3, as at most three TCP connections can be established at the same time.

#### Example

- ▶ SET /CTRL/TCP/C1.ServerIP(192.168.1.14)
- ◀ pw /CTRL/TCP/C1.ServerIP(192.168.1.14)

### 8.17.2. Setting the TCP/IP Port Number of the TCP Server

#### Command and Response

- ▶ SET /CTRL/TCP/C<loc>.ServerPort(<port\_no>)
- ◀ pw /CTRL/TCP/C<loc>.ServerPort(<port\_no>)

#### Example

- ▶ SET /CTRL/TCP/C1.ServerPort(4999)
- ◀ pw /CTRL/TCP/C1.ServerPort(4999)

### 8.17.3. Connecting to a TCP Server

#### Command and Response

- ▶ CALL /CTRL/TCP/C<loc>:connect()
- ◀ m0 /CTRL/TCP/C<loc>:connect

#### Example

- ▶ CALL /CTRL/TCP/C1:connect()
- ◀ m0 /CTRL/TCP/C1:connect

### 8.17.4. Disconnecting from a TCP Server

#### Command and Response

- ▶ CALL /CTRL/TCP/C<loc>:disconnect()
- ◀ m0 /CTRL/TCP/C<loc>:disconnect

#### Example

- ▶ CALL /CTRL/TCP/C1:disconnect()
- ◀ m0 /CTRL/TCP/C1:disconnect

### 8.17.5. Setting the Delimiter Hex

This property stores the delimiter that is between the messages (e.g. Cr, Lf, Space). The value has to be in hex format (e.g. 0D, 0A, 20).

#### Command and Response

- ▶ SET /CTRL/TCP/C<loc>.DelimiterHex=<delimiter>
- ◀ pw /CTRL/TCP/C<loc>.DelimiterHex=<delimiter>

#### Parameters

Identifier	Parameter values
<delimiter>	It can be max. 8 characters long (or 16 hex digits) in hex format.

#### Example

- ▶ SET /CTRL/TCP/C1.DelimiterHex=00
- ◀ pw /CTRL/TCP/C1.DelimiterHex=00

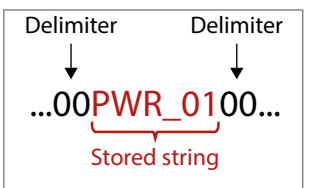

### 8.17.6. Setting the Timeout

When the set time has passed after the last received message and delimiter was not detected, the device saves the data into the **Rx**, **RxHex**, **Hash** properties. The timeout setting is useful if there is no special or easily defined delimiter in the incoming data, but there is a time gap between the messages.

#### Command and Response

- ▶ SET·/CTRL/TCP/C<loc>.Timeout=<timeout>
- ◀ pw·/CTRL/TCP/C<loc>.Timeout=<timeout>

#### Parameters

The <timeout> parameter sets the time value in milliseconds: 0 means the timeout is disabled, min. value is 10.

#### Example

- ▶ SET /CTRL/TCP/C1.Timeout=20
- ◀ pw /CTRL/TCP/C1.Timeout=20

### 8.17.7. Querying the Last Recognized Message (String)

The recognized message is stored as a string in the property below until the next recognized message or until the **clear()** method is called.

**TIPS AND TRICKS:** When this property is set as a condition in the Event Manager and the same strings follow each other, the action **will execute once**. (A Condition can be detected in Event Manager if a change happens. But if the same string is saved into the property after each other, it will not cause a change.)

#### Command and Response

- ▶ GET·/CTRL/TCP/C<loc>.Rx
- ◀ pr·/CTRL/TCP/C<loc>.Rx=<recognized\_string>

#### Parameters

Identifier	Parameter values
<recognized_string>	It can be max. 128 bytes long.

#### Example

- ▶ GET /CTRL/TCP/C1.Rx
- ◀ pr /CTRL/TCP/C1.Rx=PWR\_off

### 8.17.8. Querying the Last Recognized Message (Hex)

The recognized message is stored as a hex message in the property below until the next recognized message or until the **clear()** method is called.

#### Command and Response

- ▶ GET·/CTRL/TCP/C<loc>.RxHex
- ◀ pr·/CTRL/TCP/C<loc>.RxHex=<recognized\_hex\_data>

#### Example

- ▶ GET /CTRL/TCP/C1.RxHex
- ◀ pr /CTRL/TCP/C1.RxHex=5057525F6F6666

### 8.17.9. Clearing the Last Recognized Stored Message

This method clears the stored recognized messages from the **Rx**, **RxHex** and **Hash** properties.

#### Command and Response

- ▶ CALL·/CTRL/TCP/C<loc>:clear()
- ◀ m0·/CTRL/TCP/C<loc>:clear

#### Example

- ▶ CALL /CTRL/TCP/C1:clear()
- ◀ m0 /CTRL/TCP/C1:clear

### 8.17.10. Querying the Last Recognized Active Message (String)

The recognized data is stored in string in the property below **temporarily**. When the time set in the **ActiveTimeout** property has passed, the property is cleared.

**TIPS AND TRICKS:** When this property is set as a condition in the Event Manager and the same strings follow each other, the action **will execute on every occasion**. (A Condition can be detected in Event Manager if a change happens. In this case, the string is stored in the property and after the **ActiveTimeout** it will be cleared. If the same string is saved into the (empty) property, it will cause a change.)

#### Command and Response

- ▶ GET·/CTRL/TCP/C<loc>.ActiveRx
- ◀ pr·/CTRL/TCP/C<loc>.ActiveRx=<recognized\_string>

#### Parameters

Identifier	Parameter values
<recognized_string>	It can be a max. 12-byte-long recognized data string.

#### Example

- ▶ GET /CTRL/TCP/C1.ActiveRx
- ◀ pr /CTRL/TCP/C1.ActiveRx=AudOut+

**INFO:** Please note that the property contains the string until the **ActivePropertyTimeout** has passed only.

### 8.17.11. Querying the Last Recognized Active Message (Hex)

#### Command and Response

- ▶ GET-/CTRL/TCP/C<loc>.ActiveRxHex
- ◀ pr-/CTRL/TCP/C<loc>.ActiveRxHex=<recognized\_hex>

#### Parameters

Identifier	Parameter values
<recognized_hex>	It is the recognized data in hex format.

#### Example

- ▶ GET /CTRL/TCP/C1.ActiveRxHex
  - ◀ pr /CTRL/TCP/C1.ActiveRxHex=4175644F75742B00
- INFO: Please note that the property contains the data until the **ActivePropertyTimeout** has passed only.

### 8.17.12. Setting the Active Timeout

This property is responsible for clearing the **ActiveRx**, **ActiveRxHex**, **ActiveHash** properties after the elapsed time. Default value is 50ms.

#### Command and Response

- ▶ SET-/CTRL/TCP/C<loc>.ActivePropertyTimeout=<a\_timeout>
- ◀ pw-/CTRL/TCP/C<loc>.ActivePropertyTimeout=<a\_timeout>

#### Parameters

Identifier	Parameter values
<a_timeout>	It is the active timeout value (ms) between 0 and 255.

#### Example

- ▶ SET /CTRL/TCP/C1.ActivePropertyTimeout=255
- ◀ pw /CTRL/TCP/C1.ActivePropertyTimeout=255

### 8.17.13. Running an Immediate Event Action

When a message is recognized (DelimiterHex is detected in the message, or TimeOut has passed since receiving the last data bit), a specific Action of an Event can be run by the following command.

#### Command and Response

- ▶ SET-/CTRL/TCP/C<loc>.ActionTrigger=<event\_nr>
- ◀ pw-/CTRL/TCP/C<loc>.ActionTrigger=<event\_nr>

#### Parameters

Identifier	Parameter values
<event_nr>	It means the number (location) of the linked Event Action without the letter 'E'. (There is no need to define a Condition in the linked Event.)

#### Example

- ▶ SET /CTRL/TCP/C1.ActivePropertyTimeout=255
- ◀ pw /CTRL/TCP/C1.ActivePropertyTimeout=255

## 8.18. HTTP Messaging

**DIFFERENCE:** This feature and the commands below are available from FW package v1.3.0.

Http **post** and **put** messages can be sent from the Lightware device for more integration with third-party devices. #http

**ATTENTION!** This feature means posting or putting **HTTP** messages from the Lightware device to another device. Encrypted transmission (**HTTPS**) is not supported.

### 8.18.1. Setting the Target IP Address

#### Command and Response

- ▶ SET-/CTRL/HTTP/C1.ServerIP=<IP\_address>
- ◀ pw-/CTRL/HTTP/C1.ServerIP=<IP\_address>

#### Example

- ▶ SET /CTRL/HTTP/C1.ServerIP=192.168.0.220
- ◀ pw /CTRL/HTTP/C1.ServerIP=192.168.0.220

### 8.18.2. Setting the TCP Port

#### Command and Response

- ▶ SET-/CTRL/HTTP/C1.ServerPort=<port\_no>
- ◀ pw-/CTRL/HTTP/C1.ServerPort=<port\_no>

#### Example

- ▶ SET /CTRL/HTTP/C1.ServerPort=80
- ◀ pw /CTRL/HTTP/C1.ServerIP=80

### 8.18.3. Setting the Target Path

This property sets the path in the target device where the post/put message is to be sent.

#### Command and Response

- ▶ SET-/CTRL/HTTP/C1.File=<path>
- ◀ pw-/CTRL/HTTP/C1.File=<path>

#### Example

- ▶ SET /CTRL/HTTP/C1.File=/putxml
- ◀ pw /CTRL/HTTP/C1.File=/putxml



### 8.18.4. Setting the Message Header

#### Command and Response

- ▶ SET:/CTRL/HTTP/C1.Header=<header\_text>
- ◀ pw:/CTRL/HTTP/C1.Header=<header\_text>

#### Example

- ▶ SET /CTRL/HTTP/C1.Header=Host: 192.168.0.220\r\nContent-Type: text/xml\r\nAuthorization: Basic YWRtaW46TGlnaHR3YXJIMDE=
- ◀ pw /CTRL/HTTP/C1.Header=Host: 192.168.0.220\r\nContent-Type: text/xml\r\nAuthorization: Basic YWRtaW46TGlnaHR3YXJIMDE=

### 8.18.5. Sending a Post Message

#### Command and Response

- ▶ CALL:/CTRL/HTTP/C1:post(<body\_text>)
- ◀ mO:/CTRL/HTTP/C1:post

#### Example

- ▶ CALL /CTRL/HTTP/C1:post(<Command><Message><Send><Text>LI1R\_P</Text></Send></Message></Command>)
- ◀ mO /CTRL/HTTP/C1:post

### 8.18.6. Sending a Put Message

#### Command and Response

- ▶ CALL:/CTRL/HTTP/C1:put(<body\_text>)
- ◀ mO:/CTRL/HTTP/C1:put

#### Example

- ▶ CALL /CTRL/HTTP/C1:put(<Command><Message><Send><Text>LI1R\_P</Text></Send></Message></Command>)
- ◀ mO /CTRL/HTTP/C1:put

## 8.19. CEC Command Sending

**DIFFERENCE:** This feature is available from firmware v1.1.0.

The device is able to send and receive Consumer Electronics Control (CEC) commands. This feature is for remote controlling the source or sink device. CEC is a bi-directional communication via HDMI cable.

**INFO:** According to the standard, the CEC feature only works at HDMI ports.

**INFO:** The hidden first 2 bytes of the CEC command are static, they refer to the logical address of the sender and the addressee. When the port is input, it is always 04 (from TV to Playback device 1.); when the port is output, it is always 40 (from Playback device 1. to TV). Broadcast addressing is also possible (in this case it is 0F or 4F). #cec

### 8.19.1. Press&Release Commands

**DIFFERENCE:** This command is available from firmware v1.3.0.

The CEC commands below are called 'push-button commands', e.g. volume up/down. When the CEC command is sent, the 'release' command is also sent in the background. Certain devices require this feature for the proper working, but this is necessary only for push-button commands.

#### Command and Response

- ▶ CALL:/MEDIA/CEC/<port>:sendClick(<command>)
- ◀ mO:/MEDIA/CEC/<port>:sendClick

#### Parameters

The <port> parameter means the video input (I1-I4) or video output (O1-O2) port. The following are accepted as <commands>:

ok	number_2	input_select	rewind	select_media_4
back	number_3	display_info	fast_forward	select_media_5
up	number_4	power_legacy	eject	power_toggle
down	number_5	page_up	skip_forward	power_on
left	number_6	page_down	skip_backward	power_off
right	number_7	volume_up	3d_mode	stop_function
root_menu	number_8	volume_down	stop_record	f1
setup_menu	number_9	mute_toggle	pause_record	f2
contents_menu	dot	mute	play_forward	f3
favorite_menu	enter	unmute	play_reverse	f4
media_top_menu	clear	play	select_next_media	
media_context_menu	channel_up	stop	select_media_1	
number_0	channel_down	pause	select_media_2	
number_1	sound_select	record	select_media_3	

#### Example

- ▶ CALL /MEDIA/CEC/I2:sendClick(play)
- ◀ mO /MEDIA/CEC/I2:sendClick

### 8.19.2. Further Commands

#### Command and Response

- ▶ CALL /MEDIA/CEC/<port>:send(<command>)
- ◀ mO /MEDIA/CEC/<port>:send

#### Parameters

The <port> parameter means the video input (I1-I4) or video output (O1-O2) port. The following are accepted as <commands>:

image_view_on	standby	text_view_on	active_source	give_power_status
standby	get_cec_version	set_osd	clear_osd	

The **set\_osd** command requires to also send another command, see the following section.

#### Example

- ▶ CALL /MEDIA/CEC/I2:send(standby)
- ◀ mO /MEDIA/CEC/I2:send

### 8.19.3. Sending an OSD String

The OSD string sending consists of two steps. First, set the **OsdString** property with the desired text, then call the **send** method.

#### Command and Response

- ▶ SET /MEDIA/CEC/<port>.OsdString=<text>
- ◀ pw /MEDIA/CEC/<port>.OsdString=<text>
- ▶ CALL /MEDIA/CEC/<port>:send(set\_osd)
- ◀ mO /MEDIA/CEC/I2:send

#### Parameters

Parameter	Parameter description	Values	Value description
<port>	Video input or video output port	I1-I4	Video inputs
		O1-O2	Video outputs
<text>	The desired OSD string		Letters (A-Z) and (a-z), hyphen (-), underscore (_), numbers (0-9), and dot (.). Max length: 14 characters.

#### Example

- ▶ SET /MEDIA/CEC/I2.OsdString=Lightware
- ◀ pw /MEDIA/CEC/I2.OsdString=Lightware
- ▶ CALL /MEDIA/CEC/I2:send(set\_osd)
- ◀ mO /MEDIA/CEC/I2:send

### 8.19.4. Sending CEC Commands in Hex Format

- ▶ CALL /MEDIA/CEC/<port>:sendHex(<hex\_code>)
- ◀ mO /MEDIA/CEC/<port>:sendHex

#### Parameters

Parameter	Parameter description	Values	Value description
<port>	Video input or video output port	I1-I4	Video inputs
		O1-O2	Video outputs
<hex_code>	The desired CEC command		Max. 30 characters (15 bytes) in hexadecimal format.

#### Example

- ▶ CALL /MEDIA/CEC/I2:sendHex(8700E091)
- ◀ mO /MEDIA/CEC/I2:sendHex

### 8.19.5. Querying the Last Received CEC Message

- ▶ GET /MEDIA/CEC/<port>.LastReceivedMessage
- ◀ pr /MEDIA/CEC/<port>.LastReceivedMessage=<CEC\_message>

#### Parameters

Parameter	Parameter description	Values	Value description
<port>	Video port	I1-I4 or O1-O2	
<CEC_message>	The last incoming CEC message from the connected device.		

#### Example

- ▶ GET /MEDIA/CEC/I2.LastReceivedMessage
- ◀ pr /MEDIA/CEC/I2.LastReceivedMessage=give\_power\_status

**TIPS AND TRICKS:** This property can be a condition in the Event Manager. When the connected device sends status information via CEC, it could be a trigger for an action.

## 8.20. Event Manager Basics

The graphical interface of the Event Manager can be found in the LDC, which allows creating any kind of Event. In certain cases, the Events have to be arranged or modified by LW3 commands from another device. These commands are detailed in the coming sections.

### 8.20.1. How to arrange an Event?

The following are necessary to have a successful event:

- Defining the **Condition**
- Defining the **Action**
- Setting the **Delay** (optional)
- **Name** the Event and set to **Enabled**

INFO: Setting the Event to **Enabled** as the last step is recommended.

### 8.20.2. Setting a Condition by Specifying a Direct Path

#### Command and Response

- ▶ SET /EVENTS/E<loc>.Condition=<expression>
- ◀ pw /EVENTS/E<loc>.Condition=<expression>

#### Parameters

The structure of the <expression> is: <node\_path>.<property>=<value>.

#### Example 1

- ▶ SET /EVENTS/E1.Condition=/MEDIA/VIDEO/I1.SignalPresent=1
- ◀ pw /EVENTS/E1.Condition=/MEDIA/VIDEO/I1.SignalPresent=1

The Condition is fulfilled if the **SignalPresent** property changes to '1'.

#### Example 2

In some cases, the opposite is necessary: when the property does **not** equal with the value. If you need so, the **ConditionInverted** property must be set to **true**:

- ▶ SET /EVENTS/E2.Condition=/MEDIA/VIDEO/O1.ConnectedSource=I1
- ◀ pw /EVENTS/E2.Condition=/MEDIA/VIDEO/O1.ConnectedSource=I1
- ▶ SET /EVENTS/E2.ConditionInverted=true
- ◀ pw /EVENTS/E2.ConditionInverted=true

The Condition is fulfilled if the **ConnectedSource** property does not equal with 'I1' (in other words: if other input port is connected to O1 than I1).

#### Example 3

Sometimes, it is enough if the value of a property changes to anything. In this case, just put a **?** to the end of the property:

- ▶ SET /EVENTS/E3.Condition=/MEDIA/VIDEO/O1.ConnectedSource?
- ◀ pw /EVENTS/E2.Condition=/MEDIA/VIDEO/O1.ConnectedSource?

### 8.20.3. Setting a Condition by Linking Another Condition

#### Command and Response

- ▶ SET /EVENTS/E<loc>.Condition=<event\_nr>
- ◀ pw /EVENTS/E<loc>.Condition=<event\_nr>

#### Parameters

Identifier	Parameter values
<event_nr>	It means the number (location) of the linked Event without the letter 'E'.

#### Example

- ▶ SET /EVENTS/E2.Condition=1
- ◀ pw /EVENTS/E2.Condition=1

The Condition of the E2 Event is set to be the same as set at E1 Event.

### 8.20.4. Setting a Condition by Linking Conditions

**DIFFERENCE:** This command is available from FW package v1.3.0.

The first generation of the Event Manager is able to sense a change (one Condition), but in some cases that is not enough. The practical experience has shown there is a need to examine more conditions as follows: one/two/three Conditions exist, and one more Condition occurs. This way, you can link up to four Conditions as follows:

#### Command and Response

- ▶ SET /EVENTS/E<loc>.Condition=<event\_nr>&<event\_nr>&<event\_nr>&<event\_nr>
- ◀ pw /EVENTS/E<loc>.Condition=<event\_nr>&<event\_nr>&<event\_nr>&<event\_nr>

#### Parameters

Identifier	Parameter values
<event_nr>	It means the number (location) of the linked Event without the letter 'E'.

#### Example

- ▶ SET /EVENTS/E3.Condition=1&2
- ◀ pw /EVENTS/E3.Condition=1&2

If the Condition of E1 Event exists and the Condition of E2 is detected (or vice versa), the Condition of E3 will be fulfilled and the Action of E3 will be launched.

TIPS AND TRICKS: You do not have to define Actions for E1 and E2 Events and you can leave those **Disabled**.

### 8.20.5. Setting an Action by Specifying a Direct Path

#### Command and Response

- ▶ SET /EVENTS/E<loc>.Action=<expression>
- ◀ pw /EVENTS/E<loc>.Action=<expression>

#### Parameters

The structure of the <expression> is: <node\_path>.<property\_or\_method>=<value>. Properties and methods are handled in the same way: dot (.) stands after the path in both cases, colon (:) is not used. The <value> parameter is optional in case of certain methods.

#### Example

- ▶ SET /EVENTS/E1.Action=/MEDIA/VIDEO/XP.switch=I4:01
- ◀ pw /EVENTS/E1.Action=/MEDIA/VIDEO/XP.switch=I4:01

### 8.20.6. Setting an Action by Linking Another Action

#### Command and Response

- ▶ SET /EVENTS/E<loc>.Action=<event\_nr>
- ◀ pw /EVENTS/E<loc>.Action=<event\_nr>

#### Parameters

Identifier	Parameter values
<event_nr>	It means the number (location) of the linked Event without the letter 'E'.

#### Example

- ▶ SET /EVENTS/E2.Action=1
- ◀ pw /EVENTS/E2.Action=1

The Action of the E2 Event is set to be the same as set at E1 Event.

### 8.20.7. Setting an Action by Linking a Macro

**DIFFERENCE:** This command is available from FW package v1.3.0.

#### Command and Response

- ▶ SET /EVENTS/E<loc>.Action=<macro\_name>
- ◀ pw /EVENTS/E<loc>.Action=<macro\_name>

#### Parameters

The <macro\_name> means the name of the macro that can be seen in LDC (see the [Macros](#) section) or can be queried by the `GET /CTRL/MACROS.<id>` command.

#### Example

- ▶ SET /EVENTS/E1.Action=Macro1
- ◀ pw /EVENTS/E2.Action=Macro1

## 8.21. Event Manager Tool Kit

### 8.21.1. Setting the Delay

In most cases, the Action is performed immediately after the Condition is detected. But sometimes a delay is necessary between the Condition and the Action, thus the following delay options are defined:

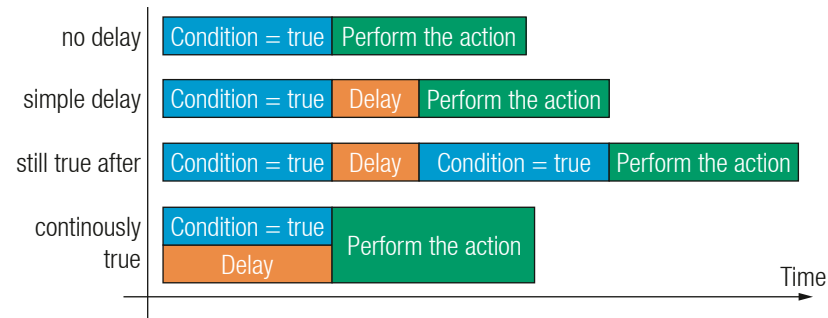

#### Command and Response (summary)

- ▶ SET /EVENTS/E<loc>.ConditionTimeout=<time>
- ◀ pw /EVENTS/E<loc>.ConditionTimeout=<time>
- ▶ SET /EVENTS/E<loc>.ConditionEndCheck=<true/false>
- ◀ pw /EVENTS/E<loc>.ConditionEndCheck=<true/false>
- ▶ SET /EVENTS/E<loc>.ConditionTimeoutContinuous=<true/false>
- ◀ pw /EVENTS/E<loc>.ConditionTimeoutContinuous=<true/false>

#### Parameters

The <time> parameter means seconds. Set the following properties for the desired delay type:

Delay type	Properties to set	Value	Result
no delay	/EVENTS/E<loc>.ConditionTimeout	0	The Action will be launched after the Condition is detected.
simple delay	/EVENTS/E<loc>.ConditionTimeout	<time>	If the Condition is detected, the action will be launched after the set time.
still true after	/EVENTS/E<loc>.ConditionTimeout	<time>	The Condition is fulfilled only if it is detected after the set time again.
	/EVENTS/E<loc>.ConditionEndCheck	true	
continuously true	/EVENTS/E<loc>.ConditionTimeout	<time>	The Condition is fulfilled only if it is existing <b>continuously</b> during the set time.
	/EVENTS/E<loc>.ConditionEndCheck	true	
	/EVENTS/E<loc>.ConditionTimeoutContinuous	true	

#### Example 1 (simple delay)

- ▶ SET /EVENTS/E1.ConditionTimeout=10
- ◀ pw /EVENTS/E1.ConditionTimeout=10

If the Condition is detected (the **ConditionDetect** property becomes **true**), the **ConditionTimeoutPending** property becomes **true**. 10 seconds later the **ConditionTimeoutPending** property becomes **false**, and the set Action is launched.

#### Example 2 ('still true after' delay type)

- ▶ SET /EVENTS/E1.ConditionTimeout=10
- ◀ pw /EVENTS/E1.ConditionTimeout=10
- ▶ SET /EVENTS/E1.ConditionTimeoutPending=true
- ◀ pw /EVENTS/E1.ConditionTimeoutPending=true

If the Condition is detected (the **ConditionDetect** property becomes **true**), the **ConditionTimeoutPending** property becomes **true**. 10 seconds later the Condition is checked again (the **ConditionTimeoutPending** property becomes **false**). If the Condition can be detected again (the **ConditionDetect** property becomes **true** again), the Condition is fulfilled and the set Action is launched.

#### Example 3 ('continuously true' delay type)

- ▶ SET /EVENTS/E1.ConditionTimeout=10
- ◀ pw /EVENTS/E1.ConditionTimeout=10
- ▶ SET /EVENTS/E1.ConditionTimeoutContinuous=true
- ◀ pw /EVENTS/E1.ConditionTimeoutContinuous=true

If the Condition is detected (the **ConditionDetect** property becomes **true**), the **ConditionTimeoutPending** property becomes **true**. If the Condition can be detected in the following 10 seconds continuously (the **ConditionDetect** property stays **true**), the Condition is fulfilled, the **ConditionTimeoutPending** property becomes **false**, and the set Action is launched.

### 8.21.2. Setting the Name of the Event

#### Command and Response

- ▶ SET /EVENTS/E<loc>.Name=<string>
- ◀ pw /EVENTS/E<loc>.Name=<string>

#### Parameters

The <string> may contain letters (A-Z) and (a-z), numbers (0-9), special characters: hyphen ( - ), underscore ( \_ ), and space ( ) up to 20 characters. Longer strings result in an error, unaccepted characters are skipped.

#### Example

- ▶ SET /EVENTS/E1.Name=Projector\_ON
- ◀ pw /EVENTS/E1.Name=Projector\_ON

### 8.21.3. Enabling/Disabling an Event

#### Command and Response

- ▶ SET-/EVENTS/E<loc>.Enabled=<true/false>
- ◀ pw-/EVENTS/E<loc>.Enabled=<true/false>

#### Parameters

When the property value is **true** (or **1**), the Action will be launched if the Condition is detected. If the property is **false** (or **0**), the Action will not run, however, the Condition counter will be increased when detected.

#### Example

- ▶ SET /EVENTS/E1.Enabled=true
- ◀ pw /EVENTS/E1.Enabled=true

### 8.21.4. Triggering a Condition

**DIFFERENCE:** This command is available from FW package v1.3.0.

This feature works like a condition is fulfilled. When a complex control system is built, a Condition may trigger numerous Actions. A typical example is when a system is powered on and the 'ready-to-use' state has to be loaded. In this case, there could be many actions that are based on the same condition. In order to reduce the number of the commands, you can trigger one 'key' condition, which starts the whole process.

#### Command and Response

- ▶ CALL-/EVENTS/E<loc>:triggerCondition(1)
- ◀ mO-/EVENTS/E<loc>:triggerCondition

#### Example

- ▶ CALL /EVENTS/E1:triggerCondition(1)
- ◀ mo /EVENTS/E1:triggerCondition

The Condition of Event1 is fulfilled, the set Action will be launched (after the delay if set).

### 8.21.5. Querying the Condition Counter

This property shows how many times the Condition has been detected and triggered altogether. The counter is reset at boot.

#### Command and Response

- ▶ GET-/EVENTS/E<loc>.ConditionCount
- ◀ pw-/EVENTS/E<loc>.ConditionCount=<num\_value>

#### Example

- ▶ GET /EVENTS/E1.ConditionCount
- ◀ pw /EVENTS/E1>.ConditionCount=5

### 8.21.6. Querying the Condition Trigger Counter

**DIFFERENCE:** This command is available from FW package v1.3.0.

This property shows how many times the Condition has been triggered, but does not contain the number of real detections. The counter is reset at boot.

#### Command and Response

- ▶ GET-/EVENTS/E<loc>.ExternalConditionTriggerCount
- ◀ pw-/EVENTS/E<loc>.ExternalConditionTriggerCount=<num\_value>

#### Example

- ▶ GET /EVENTS/E1.ExternalConditionTriggerCount
- ◀ pw /EVENTS/E1.ExternalConditionTriggerCount=2

### 8.21.7. Testing an Action

This tool is for launching the Action without detecting or triggering the Condition.

#### Command and Response

- ▶ CALL-/EVENTS/E<loc>:ActionTest(1)
- ◀ mO-/EVENTS/E<loc>:ActionTest

#### Example

- ▶ CALL /EVENTS/E1:ActionTest(1)
- ◀ mO /EVENTS/E1:ActionTest

## 8.22. Variable-Management

**DIFFERENCE:** This feature and the commands below are available from FW package v1.3.0.

Custom variables (30 pcs.) can be defined in number or text format, which are also available in the Event Manager. The maximum length of a variable can be 15 characters and they are stored in a non-volatile memory, thus the value is kept in case of a reboot. The type of the variable (text or string) is determined automatically based on the value. If an operation cannot be performed (e.g. adding number value to a string-type variable), error will be the response. *#variables*

### 8.22.1. Value Assignment

#### Command and Response

- ▶ SET-/CTRL/VARS/V<loc>.Value=<value>
- ◀ pw-/CTRL/VARS/V<loc>.Value=<value>

#### Parameters

Parameter	Parameter description	Value	Value description
<loc>	The location of the variable	1-30	
<value>	The value of the variable	Custom	Length can be max 15 characters. Numeric variable is defined between -2147483648 and 2147483647.

#### Example

- ▶ SET /CTRL/VARS/V1.Value=120
- ◀ pw /CTRL/VARS/V1.Value=120

### 8.22.2. Addition and Subtraction (Add Method)

The value of a numeric variable can be increased by adding a positive value or it can be decreased by adding a negative value. Minimum and maximum values can be defined as limits.

#### Command and Response

- ▶ CALL-/CTRL/VARS/V<loc>:add(<operand>;<min>;<max>)
- ◀ mO-/CTRL/VARS/V<loc>:add

#### Parameters

Parameter	Parameter description	Value	Value description
<loc>	The location of the variable	1-30	
<operand>	The value that is added to the variable	Integer	Negative value is also accepted
<min>	The lowest allowed value (optional)	Integer	Negative value is also accepted
<max>	The highest allowed value (optional)	Integer	Negative value is also accepted

If the value of the variable is higher or equals with <max>, the new value will be <max>. Likewise, in case of <min> setting: if the value of the variable is lower or equals with <min>, the new value will be <min>.

#### Examples

Change messages (CHG) can be seen after each response for the better understanding, which are not part of the command, but they can be set as described in the [Subscription](#) section.

#### Example 1 – addition

- ▶ GET /CTRL/VARS/V1.Value
- ◀ pw /CTRL/VARS/V1.Value=6
- ▶ CALL /CTRL/VARS/V1:add(1)
- ◀ mO /CTRL/VARS/V1:add
- ◀ CHG /CTRL/VARS/V1.Value=7
- ▶ CALL /CTRL/VARS/V1:add(1)
- ◀ mO /CTRL/VARS/V1:add
- ◀ CHG /CTRL/VARS/V1.Value=8
- ▶ CALL /CTRL/VARS/V1:add(2)
- ◀ mO /CTRL/VARS/V1:add
- ◀ CHG /CTRL/VARS/V1.Value=10

#### Example 2 – subtraction

- ▶ GET /CTRL/VARS/V1.Value
- ◀ pw /CTRL/VARS/V1.Value=10
- ▶ CALL /CTRL/VARS/V1:add(-2)
- ◀ mO /CTRL/VARS/V1:add
- ◀ CHG /CTRL/VARS/V1.Value=8
- ▶ CALL /CTRL/VARS/V1:add(-2)
- ◀ mO /CTRL/VARS/V1:add
- ◀ CHG /CTRL/VARS/V1.Value=6
- ▶ CALL /CTRL/VARS/V1:add(-10)
- ◀ mO /CTRL/VARS/V1:add
- ◀ CHG /CTRL/VARS/V1.Value=-4

#### Example 3 – addition with 'max' value

- ▶ GET /CTRL/VARS/V1.Value
- ◀ pw /CTRL/VARS/V1.Value=16
- ▶ CALL /CTRL/VARS/V1:add(2;10;20)
- ◀ mO /CTRL/VARS/V1:add
- ◀ CHG /CTRL/VARS/V1.Value=18
- ▶ CALL /CTRL/VARS/V1:add(2;10;20)
- ◀ mO /CTRL/VARS/V1:add
- ◀ CHG /CTRL/VARS/V1.Value=20
- ▶ CALL /CTRL/VARS/V1:add(2;10;20)
- ◀ mO /CTRL/VARS/V1:add
- ◀ CHG /CTRL/VARS/V1.Value=20

#### Example 4 – subtraction with 'min' value

- ▶ GET /CTRL/VARS/V1.Value
- ◀ pw /CTRL/VARS/V1.Value=14
- ▶ CALL /CTRL/VARS/V1:add(-2;10;20)
- ◀ mO /CTRL/VARS/V1:add
- ◀ CHG /CTRL/VARS/V1.Value=12
- ▶ CALL /CTRL/VARS/V1:add(-2;10;20)
- ◀ mO /CTRL/VARS/V1:add
- ◀ CHG /CTRL/VARS/V1.Value=10
- ▶ CALL /CTRL/VARS/V1:add(-2;10;20)
- ◀ mO /CTRL/VARS/V1:add
- ◀ CHG /CTRL/VARS/V1.Value=10

### 8.22.3. Addition and Subtraction (Cycle Method)

The value of a numeric variable can be increased by adding a positive value or it can be decreased by adding a negative value. Minimum and maximum values can be defined as limits. This method has the feature that if the value hits the limit (min/max), the value will be stepped to the other end of the interval.

#### Command and Response

- ▶ `CALL /CTRL/VARS/V<loc>:cycle(<operand>;<min>;<max>)`
- ◀ `mO /CTRL/VARS/V<loc>:cycle`

#### Parameters

Parameter	Parameter description	Value	Value description
<loc>	The location of the variable	<b>1-30</b>	
<operand>	The value that is added to the variable	<b>Integer</b>	Negative value is also accepted
<min>	The lowest allowed value (optional)	<b>Integer</b>	Negative value is also accepted
<max>	The highest allowed value (optional)	<b>Integer</b>	Negative value is also accepted

If the calculated value is beyond the limit (min/max), the value will be stepped to the other end of the interval.

#### Examples

Change messages (CHG) can be seen after each response for the better understanding, which are not part of the command, but they can be set as described in the [Subscription](#) section.

#### Example 1 – addition

- ▶ `GET /CTRL/VARS/V1.Value`
- ◀ `pw /CTRL/VARS/V1.Value=18`
- ▶ `CALL /CTRL/VARS/V1:cycle(1;10;20)`
- ◀ `mO /CTRL/VARS/V1:cycle`
- ◀ `CHG /CTRL/VARS/V1.Value=19`
- ▶ `CALL /CTRL/VARS/V1:cycle(1;10;20)`
- ◀ `mO /CTRL/VARS/V1:cycle`
- ◀ `CHG /CTRL/VARS/V1.Value=20`
- ▶ `CALL /CTRL/VARS/V1:cycle(1;10;20)`
- ◀ `mO /CTRL/VARS/V1:cycle`
- ◀ `CHG /CTRL/VARS/V1.Value=10`
- ▶ `CALL /CTRL/VARS/V1:cycle(1;10;20)`
- ◀ `mO /CTRL/VARS/V1:cycle`
- ◀ `CHG /CTRL/VARS/V1.Value=11`

#### Example 2 – subtraction

- ▶ `GET /CTRL/VARS/V1.Value`
- ◀ `pw /CTRL/VARS/V1.Value=13`
- ▶ `CALL /CTRL/VARS/V1:cycle(-2;10;20)`
- ◀ `mO /CTRL/VARS/V1:cycle`
- ◀ `CHG /CTRL/VARS/V1.Value=11`
- ▶ `CALL /CTRL/VARS/V1:cycle(-2;10;20)`
- ◀ `mO /CTRL/VARS/V1:cycle`
- ◀ `CHG /CTRL/VARS/V1.Value=20`
- ▶ `CALL /CTRL/VARS/V1:cycle(-2;10;20)`
- ◀ `mO /CTRL/VARS/V1:cycle`
- ◀ `CHG /CTRL/VARS/V1.Value=18`

### 8.22.4. Value Change with Intervals (Case)

This command can be used to change the value of a variable if it fits in any of the defined intervals.

#### Command and Response

- ▶ `CALL /CTRL/VARS/V<loc>:case(<min> <max> <val>;)`
- ◀ `mO /CTRL/VARS/V<loc>:case`

#### Parameters

Parameter	Parameter description	Value
<loc>	The location of the variable	<b>1-30</b>
<min>	The lowest value of the interval	<b>Integer</b>
<max>	The highest value of the interval	<b>Integer</b>
<val>	The new value that will be valid if the current value is in the interval	<b>Integer</b>

The parameters are divided by a space character, and the interval groups are divided by semicolons. Up to 16 cases can be defined.

#### Examples

- ▶ `CALL /CTRL/VARS/V1:case(10 20 15)`
- ◀ `mO /CTRL/VARS/V1:case`

A typical example is when two different ranges of values have to meet:

Incoming values: between 0 and 255 (e.g. the slider of a controller can have these values).

Outgoing values: between 0 and 100 (e.g. the controlled device accepts these values).

Defined cases:

	Min	Max	New value
Case 1	1	25	10
Case 2	26	50	20
Case 3	51	75	30
Case 4	76	100	40
Case 5	101	125	50
Case 6	126	150	60
Case 7	151	175	70
Case 8	176	200	80
Case 9	201	225	90
Case 10	226	255	100

The command looks like:

- ▶ `CALL /CTRL/VARS/V1:case(1 25 10;26 50 20;51 75 30;76 100 40;101 125 50;126 150 60;151 175 70;176 200 80;201 225 90;226 255 100)`
- ◀ `mO /CTRL/VARS/V1:case`



### 8.22.5. Scan and Store

This command can be used to get the value (or a part of the value) of an LW3 property. The defined path will be scanned according to the pattern and the result will be the value of the variable (number or string type).

#### Command and Response

- ▶ `CALL /CTRL/VARS/V<loc>:scanf(<path>.<property>;<pattern>)`
- ◀ `mO /CTRL/VARS/V<loc>:scanf`

#### Parameters

Parameter	Parameter description	Value
<loc>	The location of the variable	<b>1-30</b>
<path>.<property>	The LW3 property with node	
<pattern>	The pattern that scans the property for the desired result	<b>see below</b>

#### Pattern options

Pattern	Pattern description
%s	String of characters stopping at the first whitespace character
%<number>s	The next <number> of characters (string) stopping at the first whitespace
%c	One character
%<number>c	The next <number> of characters
%[<characters>]	Defined character set, specified between brackets
%^[<characters>]	Negated character set that will be skipped, specified between brackets
%*	Ignored part
<custom_text>	User-defined text

The patterns can be combined to get the desired result as shown in the examples.

**ATTENTION!** Do not forget to escape the % character as shown in the example below.

#### Examples

- ▶ `CALL /CTRL/VARS/V1:scanf(/MEDIA/AUDIO/XP.SourcePortStatus;\%5c)`
- ◀ `mO /CTRL/VARS/V1:scanf`
- ▶ `GET /CTRL/VARS/V1.Value`
- ◀ `pw /CTRL/VARS/V1.Value=T00AA`

A simple pattern has been applied: we need the first five characters from the property value.

#### Further Examples

<path>.<property>	Property Value	<pattern>	Scanned result
/MANAGEMENT/STATUS.CpuTemperature	42 C; 0;75; 0;7	%s	42
/MANAGEMENT/STATUS.CpuFirmware	1.6.0b10 r96	%12s	1.6.0b10
/MEDIA/VIDEO/XP.DestinationPortStatus	T00AA;T00AF	%6c	T00AA
/MEDIA/UART/P1.Rs232Configuration	57600, 8N1	%*[^,], %s	8N1
/MEDIA/AUDIO/XP.SourcePortStatus	T000A;T000B;T000F	%*6c%5c	T000B
/MANAGEMENT/NETWORK.HostName	lightware-00005031	lightware-%[0-9]	00005031

### 8.22.6. Reformatting a Value

The value of the variable can be changed by adding text as prefix and/or postfix.

**ATTENTION!** Think about the length of the value: 15 characters are allowed, the others are truncated.

#### Command and Response

- ▶ `CALL /CTRL/VARS/V<loc>:printf(<prefix>%s<postfix>)`
- ◀ `mO /CTRL/VARS/V<loc>:printf`

#### Parameters

Parameter	Parameter description	Value	Value description
<loc>	The location of the variable	<b>1-30</b>	
<prefix>	The text before the original value of the property (optional)	<b>Custom</b>	ASCII characters
%s	The original value of the variable		
<postfix>	The text following the original value of the property (optional)	<b>Custom</b>	ASCII characters

#### Example

- ▶ `GET /CTRL/VARS/V1.Value`
- ▶ `pw /CTRL/VARS/V1.Value=01`
- ▶ `CALL /CTRL/VARS/V1:printf(PWR%s)`
- ◀ `mO /CTRL/VARS/V1:printf`
- ▶ `GET /CTRL/VARS/V1.Value`
- ◀ `pw /CTRL/VARS/V1.Value=PWR01`

The 'PWR' string has been inserted before the original value.

## 8.23. Ethernet Tool Kit

**DIFFERENCE:** This feature and the commands below are available from FW package v1.3.0.

### 8.23.1. Device Filter Based on MAC Address

You can create a list of network devices based on the MAC address that are allowed controlling the device, or querying parameters to/from the Lightware device. *#macfilter*

**ATTENTION!** If the device is installed in a network where it gets IP address from a DHCP server and you plan to use the MAC filtering, make sure the MAC address of the DHCP server is added to the whitelist. Otherwise, the device will not get an IP address and will be unreachable.

#### Command and Response

- ▶ SET /MANAGEMENT/MACFILTER.MACAddress<loc>=<MAC\_address>;<receive>;<send>;<name>
- ◀ pw /MANAGEMENT/MACFILTER.MACAddress<loc>=<MAC\_address>;<receive>;<send>;<name>

The filter is disabled by default. Set the **FilterEnable** property to **true** as shown in the example.

#### Parameters

Parameter	Parameter description	Values	Value description
<loc>	Location of the address	1-8	The default values of 1, 2 and 3 ensure that address resolution and device discovery continue to work after enabling the MAC filter
<MAC_address>	The MAC address of the device	Unique value	Hex format, divided by a colon
<receive>	Enable/disable the parameter querying option	false (or 0)	The device is <b>not allowed</b> to query parameters from the LW device
		true (or 1)	The device is <b>allowed</b> to query parameters from the LW device
<send>	Enable/disable the parameter setting option	false (or 0)	The device is <b>not allowed</b> to change parameters in the LW device
		true (or 1)	The device is <b>allowed</b> to change parameters in the LW device
<name>	Unique name for the better identification (optional)	Any string	Up to 5 ASCII characters (longer names are truncated)

#### Example

- ▶ SET /MANAGEMENT/MACFILTER/MACAddress4=(04:D4:C4:4D:01:43;1;1;Tech)
- ◀ pw /MANAGEMENT/MACFILTER/MACAddress4=(04:D4:C4:4D:01:43;1;1;Tech)
- ▶ SET /MANAGEMENT/MACFILTER.FilterEnable=true
- ◀ pw /MANAGEMENT/MACFILTER.FilterEnable=true

New MAC address is saved into the 4th property with the name 'Tech', which may query/set parameters from/in the Lightware device. The **FilterEnable** property is set to **true**, thus the filter is enabled.

### 8.23.2. Blocking the LW2 Control Port

This command is for blocking the LW2 control port; it is an additional protection for the Cleartext login function.

#### Command and Response *#portblock*

- ▶ SET /MANAGEMENT/SERVICEFILTER.Lw2Enabled=<port\_mode>
- ◀ pw /MANAGEMENT/SERVICEFILTER.Lw2Enabled=<port\_mode>

#### Example

- ▶ SET /MANAGEMENT/SERVICEFILTER.Lw2Enabled=false
- ◀ pw /MANAGEMENT/SERVICEFILTER.Lw2Enabled=false

### 8.23.3. Blocking the HTTP Port

This command is for blocking the HTTP port (80); it is an additional protection for the Cleartext login function.

#### Command and Response

- ▶ SET /MANAGEMENT/SERVICEFILTER.HttpEnabled=<port\_mode>
- ◀ pw /MANAGEMENT/SERVICEFILTER.HttpEnabled=<port\_mode>

#### Example

- ▶ SET /MANAGEMENT/SERVICEFILTER.HttpEnabled=true
- ◀ pw /MANAGEMENT/SERVICEFILTER.HttpEnabled=true

### 8.23.4. Blocking the HTTP Post Receiving

This command is for blocking HTTP posts; it is an additional protection for the Cleartext login function.

#### Command and Response

- ▶ SET /MANAGEMENT/SERVICEFILTER.HttpEnabled=<port\_mode>
- ◀ pw /MANAGEMENT/SERVICEFILTER.HttpEnabled=<port\_mode>

#### Example

- ▶ SET /MANAGEMENT/SERVICEFILTER.HttpEnabled=true
- ◀ pw /MANAGEMENT/SERVICEFILTER.HttpEnabled=true

### 8.23.5. Powering on a Computer over Ethernet (Wake-on-LAN)

The well-known wake-on-lan feature (sending magic Packet to the target PC) is available by the following command:

#### Command and Response

- ▶ CALL /MEDIA/ETHERNET:wakeOnLan(<MAC\_address>)
- ◀ mO /MEDIA/ETHERNET:wakeOnLan

#### Example

- ▶ CALL /MEDIA/ETHERNET:wakeOnLan(AA:BB:CC:22:14:FF)
- ◀ mO /MEDIA/ETHERNET:wakeOnLan

Please make sure the feature is enabled in the target PC and it is powered (but switched off).

### 8.23.6. Setting the Host Name

**DIFFERENCE:** This command is available only from FW package v1.3.0b9.

The host name is a property that can be used instead of the IP address when connecting to the device. It is also suitable for finding it in the Device Discovery window of the LDC, see more details in the [Favorite Devices](#) section. Furthermore, it can be used to open the The Built-in Miniweb. If the IP address of the device is changing, the host name can be used as a fixed property.

#### Command and Response

- ▶ SET /MANAGEMENT/NETWORK.HostName=<unique\_name>
- ◀ pw /MANAGEMENT/NETWORK.HostName=<unique\_name>

#### Parameters

The <unique\_name> can be 1-64 characters long and the following are allowed for naming: the elements of the English alphabet and numbers. Hyphen (-) and dot (.) is also accepted, except as last character.

#### Example

- ▶ SET /MANAGEMENT/NETWORK.HostName=mtg-room1
- ◀ pw /MANAGEMENT/NETWORK.HostName=mtg-room1

## 8.24. GPIO Port Settings

**INFO:** This command is available in the MMX8x8-HDMI-4K-A-USB20 model.

### 8.24.1. Setting the Direction of a GPIO Pin

#### Command and Response #gpio

- ▶ SET /MEDIA/GPIO/<gpio\_port>.Direction=<dir>
- ◀ pw /MEDIA/GPIO/<gpio\_port>.Direction=<dir>

#### Parameters

Parameter	Parameter description	Values	Value description
<dir>	Direction of the GPIO pin	I	The direction of the GPIO pin is set to input.
		O	The direction of the GPIO pin is set to output.

#### Example

- ▶ SET /MEDIA/GPIO/P1.Direction=I
- ◀ pw /MEDIA/GPIO/P1.Direction=I

### 8.24.2. Setting the Output Level of a GPIO Pin

#### Command and Response

- ▶ SET /MEDIA/GPIO/<gpio\_port>.Output=<value>
- ◀ pw /MEDIA/GPIO/<gpio\_port>.Output=<value>

#### Parameters

Identifier	Parameter description	Parameter values
<gpio_port>	GPIO port number	P1-P6
<value>	Value of the GPIO pin	H: High level L: Low level

#### Example

- ▶ SET /MEDIA/GPIO/P1.Output=H
- ◀ pw /MEDIA/GPIO/P1.Output=H

### 8.24.3. Toggling the Level of a GPIO Pin

#### Command and Response

- ▶ CALL /MEDIA/GPIO/<gpio\_port>:toggle()
- ◀ pw /MEDIA/GPIO/ <gpio\_port>:toggle

#### Example

- ▶ CALL /MEDIA/GPIO/P1:toggle()
- ◀ mO /MEDIA/GPIO/P1:toggle

If the direction of the pin is input: the output value is toggled. If the direction of the pin is output: the output value and the input value are toggled.

## 8.25. USB Port Settings

### 8.25.1. USB Host Select

#### Command and Response *#usb*

- ▶ SET /MEDIA/USB/USBSWITCH.HostSelect=<USB\_host>
- ◀ pr /MEDIA/USB/USBSWITCH.HostSelect=<USB\_host>

#### Parameters

Identifier	Parameter description	Parameter values
<USB_host>	Active USB-B port	1-4, 0 means off

#### Example

- ▶ SET /MEDIA/USB/USBSWITCH.HostSelect=1
- ◀ pr /MEDIA/USB/USBSWITCH.HostSelect=1

### 8.25.2. Power Switch Delay

#### Command and Response *#usb*

- ▶ SET /MEDIA/USB/USBSWITCH.DelayedSwitch=<delay\_status>
- ◀ pr /MEDIA/USB/USBSWITCH.DelayedSwitch=<delay\_status>

#### Parameters

Identifier	Parameter description	Parameter values
<delay_status>	2sec Power-Cut towards the devices if Host changed	true false

#### Example

- ▶ SET /MEDIA/USB/USBSWITCH.DelayedSwitch=true
- ◀ pr /MEDIA/USB/USBSWITCH.DelayedSwitch=true

### 8.25.3. Host 5V Sense

#### Command and Response

- ▶ GET /MEDIA/USB/USBSWITCH.<HostPc>
- ◀ pr /MEDIA/USB/USBSWITCH.<HostPc>=<status>

#### Parameters

Identifier	Parameter description	Parameter values
<HostPc>	ID of the host PC	Host5vSensePc1 Host5vSensePc2 Host5vSensePc3 Host5vSensePc4
<status>	Status of the connected host	true false

#### Example

- ▶ GET /MEDIA/USB/USBSWITCH.Host5vSensePc1
- ◀ pr /MEDIA/USB/USBSWITCH.Host5vSensePc1=false

### 8.25.4. Device 5V Enable

#### Command and Response

- ▶ SET /MEDIA/USB/USBSWITCH.<Device5vEnable>=<enable>
- ◀ pr /MEDIA/USB/USBSWITCH.<Device5vEnable>=<enable>

#### Parameters

Identifier	Parameter description	Parameter values
<Device5vEnable>	Device ID	Device5vEnable1 Device5vEnable2 Device5vEnable3 Device5vEnable4
<enable>	Enable the 5V power to the device	true false

#### Example

- ▶ SET /MEDIA/USB/USBSWITCH.Device5vEnable1=true
- ◀ pr /MEDIA/USB/USBSWITCH.Device5vEnable1=true

### 8.25.5. Querying the 5V Overcurrent Status of the Device

#### Command and Response

- ▶ GET /MEDIA/USB/USBSWITCH.<deviceid>
- ◀ pr /MEDIA/USB/USBSWITCH.<deviceid>=<status>

#### Parameters

Identifier	Parameter description	Parameter values
<deviceid>	ID of the host PC	Device5vOverCurrent1 Device5vOverCurrent2 Device5vOverCurrent3 Device5vOverCurrent4
<status>	Indicates if the device is in overcurrent state	true false

#### Example

- ▶ GET /MEDIA/USB/USBSWITCH.Device5vOverCurrent1
- ◀ pr /MEDIA/USB/USBSWITCH.Device5vOverCurrent1=false

## 8.26. System Monitoring Commands

### 8.26.1. Querying Video Signal Presence

SignalPresent property indicates valid signal present on the port.

#### Command and Response

- ▶ GET /MEDIA/VIDEO/<port>.SignalPresent
- ◀ pr /MEDIA/VIDEO/<port>.SignalPresent=<signal\_status>

#### Example

- ▶ GET /MEDIA/VIDEO/I1.SignalPresent
- ◀ pr /MEDIA/VIDEO/I1.SignalPresent=1

#### Parameters

Parameter	Parameter description	Values	Value description
<signal_status>	Status of the signal	0	Not present
		1	Present
		F	Unknown

### 8.26.2. Querying the Connected Device (or Cable)

Connected property indicates that cable or device is connected to the port.

#### Command and Response

- ▶ GET /MEDIA/VIDEO/<port>.Connected
- ◀ pr /MEDIA/VIDEO/<port>.Connected=<conn\_status>

#### Example

- ▶ GET /MEDIA/VIDEO/I1.Connected
- ◀ pr /MEDIA/VIDEO/I1.Connected=1

#### Parameters

Parameter	Parameter description	Values	Value description
<conn_status>	Status of the connection	0	Not present
		1	Present
		F	Unknown

### 8.26.3. Querying the Embedded Audio

EmbeddedAudioPresent property indicates that embedded audio is present in the video stream.

#### Command and Response

- ▶ GET /MEDIA/VIDEO/<port>.EmbeddedAudioPresent
- ◀ pr /MEDIA/VIDEO/<port>.EmbeddedAudioPresent =<emb\_status>

#### Example

- ▶ GET /MEDIA/VIDEO/I1.EmbeddedAudioPresent
- ◀ pr /MEDIA/VIDEO/I1.EmbeddedAudioPresent=0

#### Parameters

Parameter	Parameter description	Values	Value description
<emb_status>	Status of the embedded audio	0	Not present
		1	Present
		F	Unknown

### 8.26.4. Hotplug Detect

This property indicates that the connected source or sink is connected.

#### Command and Response

- ▶ GET /MEDIA/VIDEO/<port>.Power5vIn
- ◀ pr /MEDIA/VIDEO/<port>.Power5vIn =<power5v\_status>

#### Parameters

Parameter	Parameter description	Values	Value description
<power05v_status>	Status of the 5V	true	Indicates 5V on the port.
		false	5V is not sensed on the port.

#### Example

- ▶ GET /MEDIA/VIDEO/I6.Power5vIn
- ◀ pr /MEDIA/VIDEO/I6.Power5vIn=true

## 8.27. LW3 Quick Summary

### System Commands

#### Querying the Product Name

- ▶ GET·/.ProductName

#### Querying the Device Label

- ▶ GET·/MANAGEMENT/UID/DeviceLabel=<custom\_name>

#### Setting the Device Label

- ▶ SET·/MANAGEMENT/UID/DeviceLabel=<custom\_name>

#### Querying the Serial Number

- ▶ GET·/.SerialNumber

#### Querying the Package Version

- ▶ GET·/MANAGEMENT/UID.PackageVersion

#### Querying the CPU Firmware Version

- ▶ GET·/SYS/MB.FirmwareVersion

#### Identifying the Device

- ▶ CALL·/MANAGEMENT/UI:identifyMe()

#### Setting the Rotary Direction of the Jog Dial Knob

- ▶ SET·/MANAGEMENT/UI.RotaryDirection=<direction>

#### Running a Macro

- ▶ CALL·/CTRL/MACROS:run(<macro\_name>)

#### Control Lock

- ▶ SET·/MANAGEMENT/UI.ControlLock=<control\_state>

#### Resetting the Matrix

- ▶ CALL·/SYS:reset()

#### Restoring the Factory Default Settings

- ▶ CALL·/SYS:factoryDefaults()

### Cleartext Login Protection

#### Setting the Login Password

- ▶ CALL·/LOGIN:setPassword(<password>)

#### Logging into the Device

- ▶ CALL·/LOGIN:login(<password>)

#### Logging out of the Device

- ▶ CALL·/LOGIN:logout(<password>)

#### Enabling/Disabling the Cleartext Login Function

- ▶ SET·/LOGIN:LoginEnable=<login\_state>

### Switching and Crosspoint Settings

#### Querying the Video Crosspoint State

- ▶ GET·/MEDIA/VIDEO/XP.DestinationConnectionList

#### Switching an Input to an Output

- ▶ CALL·/MEDIA/VIDEO/XP:switch(<in>:<out>)

#### Switching an Input to All Outputs

- ▶ CALL·/MEDIA/VIDEO/XP:switchAll(<in>)

### Video Port Settings

#### Muting an Input Port

- ▶ CALL·/MEDIA/VIDEO/XP:muteSource(<in>)

#### Unmuting an Input Port

- ▶ CALL·/MEDIA/VIDEO/XP:unmuteSource(<in>)

#### Muting an Output Port

- ▶ CALL·/MEDIA/VIDEO/XP:muteDestination(<out>)

#### Unmuting an Output Port

- ▶ CALL·/MEDIA/VIDEO/XP:unmuteDestination(<out>)

#### Locking an Input Port

- ▶ CALL·/MEDIA/VIDEO/XP:lockSource(<in>)

#### Unlocking an Input Port

- ▶ CALL·/MEDIA/VIDEO/XP:unlockSource(<in>)

#### Locking an Output Port

- ▶ CALL·/MEDIA/VIDEO/XP:lockDestination(<out>)

#### Unlocking an Output Port

- ▶ CALL·/MEDIA/VIDEO/XP:unlockDestination(<out>)

#### Setting the HDCP (Input Port)

- ▶ SET·/MEDIA/VIDEO/<in>.HdcpEnable=<hdcp\_status>

**Setting the HDCP (Output Port)**

- ▶ SET·/MEDIA/VIDEO/<out>.HdcpModeSetting=<hdcp\_mode>

**Querying the Connected Input Port Number**

- ▶ GET·/MEDIA/VIDEO/<out>.ConnectedSource

**Querying the Status of the Source Port**

- ▶ GET·/MEDIA/VIDEO/XP.SourcePortStatus

**Querying the Status of the Destination Port**

- ▶ GET·/MEDIA/XP/VIDEO.DestinationPortStatus

**Querying the Video Autoselect Settings**

- ▶ GET·/MEDIA/VIDEO/XP.DestinationPortAutoselect

**Changing the Autoselect Mode**

- ▶ CALL·/MEDIA/VIDEO/XP:setDestinationPortAutoselect(<out>:<out\_set>)

**Querying the Input Port Priority**

- ▶ GET·/MEDIA/VIDEO/XP.PortPriorityList

**Changing the Input Port Priority**

- ▶ CALL·/MEDIA/VIDEO/XP:setAutoselectionPriority(<in>\(<out>\):<prio>);(<in>\(<out>\):<prio>)

**Setting the Signal Type (Output Ports)**

- ▶ SET·/MEDIA/VIDEO/<out>.HdmiModeSetting=<signal\_type>

**Test Pattern****Test pattern generator mode setting**

- ▶ SET·/MEDIA/VIDEO/<out>.TpgMode=<tpg\_mode>

**Clock source – the clock frequency of the test pattern**

- ▶ SET·/MEDIA/VIDEO/<out>.TpgClockSource=<tpg\_clocksource>

**Test pattern**

- ▶ SET·/MEDIA/VIDEO/<out>.TpgPattern=<pattern>

**EDID Management****Querying the Emulated EDIDs**

- ▶ GET·/EDID.EdidStatus

**Setting the Emulated EDID**

- ▶ CALL·/EDID:switch(<source>:<destination>)

**Copying an EDID into Another Slot**

- ▶ CALL·/EDID:copy(<source>:<destination>)

**AUX Analog Audio I/O Port Settings****Setting the Audio Mode**

- ▶ SET·/MEDIA/AUDIO/<in>.AudioMode=<audio\_mode>

**Muting/Unmuting the AUX Analog Audio Input**

- ▶ SET·/MEDIA/AUDIO/<in>/ADCVOLUME.Mute=<mute\_status>

**Setting the AUX Analog Audio Input Volume**

- ▶ SET·/MEDIA/AUDIO/<in>/ADCVOLUME.VoluedB=<volume\_dB>

**Setting the AUX Analog Audio Input Balance**

- ▶ SET·/MEDIA/AUDIO/<in>/ADCVOLUME.Balance=<balance\_value>

**Setting the AUX Analog Audio Input Gain**

- ▶ SET·/MEDIA/AUDIO/<in>/ADCVOLUME.Gain=<gain\_dB>

**Muting/Unmuting the AUX Analog Audio Output**

- ▶ SET·/MEDIA/AUDIO/<in>.DACVOLUME.Mute=<mute\_status>

**Setting the AUX Analog Audio Output Volume**

- ▶ SET·/MEDIA/AUDIO/<in>/DACVOLUME.VoluedB=<volume\_dB>

**Setting the AUX Analog Audio Output Balance**

- ▶ SET·/MEDIA/AUDIO/<in>/DACVOLUME.Balance=<balance\_value>

**Serial Port Configuration****Setting the Protocol**

- ▶ SET·/MEDIA/UART/<serial\_port>.ControlProtocol=<cont\_protocol>

**Setting the BAUD Rate**

- ▶ SET·/MEDIA/UART/<serial\_port>.Baudrate=<baudrate>

**Setting the Operation Mode**

- ▶ SET·/MEDIA/UART/<serial\_port>.Rs232Mode=<rs232\_mode>

**Enabling/Disabling the Command Injection Mode**

- ▶ SET·/MEDIA/UART/<serial\_port>.CommandInjectionEnable=<ci\_stat>

**Querying the RS-232 Command Injection Port Number**

- ▶ GET:/MEDIA/UART/<serial\_port>.CommandInjectionPort

### Serial Port Messaging

#### Sending a Message (ASCII-format) via RS-232

- ▶ CALL:/MEDIA/UART/P1:sendMessage(<message>)

#### Sending a Text (ASCII-format) via RS-232

- ▶ CALL:/MEDIA/UART/P1:sendText(<message>)

#### Sending a Binary Message (HEX-format) via RS-232

- ▶ CALL:/MEDIA/UART/P1:sendBinaryMessage(<message>)

#### Using Hexadecimal Codes

### RS-232 Message Recognizer

#### Enabling/Disabling the Recognizer

- ▶ SET:/MEDIA/UART/<serial\_port>.RecognizerEnable=<recognizer\_enable>

#### Setting the Delimiter Hex

- ▶ SET:/MEDIA/UART/RECOGNIZER.DelimiterHex=<delimiter>

#### Setting the Timeout

- ▶ SET:/MEDIA/UART/RECOGNIZER.TimeOut=<timeout>

#### Querying the Last Recognized Message (String)

- ▶ GET:/MEDIA/UART/RECOGNIZER.Rx

#### Querying the Last Recognized Message(Hex)

- ▶ GET:/MEDIA/UART/RECOGNIZER.RxHex

#### Clearing the Last Recognized Stored Message

- ▶ CALL:/MEDIA/UART/RECOGNIZER:clear()

#### Querying the Last Recognized Active Message (String)

- ▶ GET:/MEDIA/UART/RECOGNIZER.ActiveRx

#### Querying the Last Recognized Active Message (Hex)

- ▶ GET:/MEDIA/UART/RECOGNIZER.ActiveRxHex

#### Setting the Active Timeout

- ▶ SET:/MEDIA/UART/RECOGNIZER.ActivePropertyTimeout=<a\_timeout>

#### Running an Immediate Event Action

- ▶ SET:/MEDIA/UART/RECOGNIZER.ActionTrigger=<event\_nr>

### IR Port Configuration

#### Enabling/Disabling the IR Port

- ▶ SET:/MEDIA/IR/<ir\_port>.Enable=<ir\_port\_status>

#### Querying the IR Command Injection Port Number

- ▶ GET:/MEDIA/IR/<ir\_port>.CommandInjectionPort

### IR Port Messaging

#### Sending Pronto Hex Codes in Little-endian Format

- ▶ CALL /MEDIA/IR/<ir\_port>:sendProntoHex(<hex\_code>)

#### Sending Pronto Hex Codes in Big-endian Format

- ▶ CALL /MEDIA/IR/<ir\_port>:sendProntoHexBigEndian(<hex\_code>)

### Ethernet Configuration

#### Querying the Current IP Address

- ▶ GET:/MANAGEMENT/NETWORK.IpAddress

#### Querying the Current DHCP Status

- ▶ GET:/MANAGEMENT/NETWORK.DhcpEnabled

#### Setting a Dynamic IP Address

- ▶ SET:/MANAGEMENT/NETWORK.DhcpEnabled=<dhcp\_status>

#### Setting a Static IP Address

- ▶ SET:/MANAGEMENT/NETWORK.StaticIpAddress=<IP\_address>

#### Changing the Subnet Mask (Static)

- ▶ SET:/MANAGEMENT/NETWORK.StaticNetworkMask=<netmask>

#### Changing the Gateway Address (Static)

- ▶ SET:/MANAGEMENT/NETWORK.StaticGatewayAddress=<gw\_address>

#### Applying Network Settings

- ▶ CALL:/MANAGEMENT/NETWORK:ApplySettings(1)

### Ethernet Message Sending

#### Sending a TCP Message (ASCII-format)

- ▶ CALL:/MEDIA/ETHERNET:tcpMessage(<IP\_address>:<port\_no>=<message>)

#### Sending a TCP Text (ASCII-format)

- ▶ CALL:/MEDIA/ETHERNET:tcpText(<IP\_address>:<port\_no>=<text>)

#### Sending a TCP Binary Message (HEX-format)



- ▶ CALL·/MEDIA/ETHERNET.tcpBinary(<IP\_address>:<port\_no>=<HEX\_message>)

#### Sending UDP Message (ASCII-format)

- ▶ CALL·/MEDIA/ETHERNET:udpMessage(<IP\_address>:<port\_no>=<message>)

#### Sending a UDP Text (ASCII-format)

- ▶ CALL·/MEDIA/ETHERNET:udpText(<IP\_address>:<port\_no>=<text>)

#### Sending a UDP Binary Message (HEX-format)

- ▶ CALL·/MEDIA/ETHERNET:udpBinary(<IP\_address>:<port\_no>=<HEX\_message>)

### TCP Message Recognizer

#### Setting the IP Address of the TCP Server

- ▶ SET·/CTRL/TCP/C<loc>.ServerIP(<IP\_address>)

#### Setting the TCP/IP Port Number of the TCP Server

- ▶ SET·/CTRL/TCP/C<loc>.ServerPort(<port\_no>)

#### Connecting to a TCP Server

- ▶ CALL·/CTRL/TCP/C<loc>.connect()

#### Disconnecting from a TCP Server

- ▶ CALL·/CTRL/TCP/C<loc>.disconnect()

#### Setting the Delimiter Hex

- ▶ SET·/CTRL/TCP/C<loc>.DelimiterHex=<delimiter>

#### Setting the Timeout

- ▶ SET·/CTRL/TCP/C<loc>.TimeOut=<timeout>

#### Querying the Last Recognized Message (String)

- ▶ GET·/CTRL/TCP/C<loc>.Rx

#### Querying the Last Recognized Message (Hex)

- ▶ GET·/CTRL/TCP/C<loc>.RxHex

#### Clearing the Last Recognized Stored Message

- ▶ CALL·/CTRL/TCP/C<loc>.clear()

#### Querying the Last Recognized Active Message (String)

- ▶ GET·/CTRL/TCP/C<loc>.ActiveRx

#### Querying the Last Recognized Active Message (Hex)

- ▶ GET·/CTRL/TCP/C<loc>.ActiveRxHex

#### Setting the Active Timeout

- ▶ SET·/CTRL/TCP/C<loc>.ActivePropertyTimeout=<a\_timeout>

#### Running an Immediate Event Action

- ▶ SET·/CTRL/TCP/C<loc>.ActionTrigger=<event\_nr>

### HTTP Messaging

#### Setting the Target IP Address

- ▶ SET·/CTRL/HTTP/C1.ServerIP=<IP\_address>

#### Setting the TCP Port

- ▶ SET·/CTRL/HTTP/C1.ServerPort=<port\_no>

#### Setting the Target Path

- ▶ SET·/CTRL/HTTP/C1.File=<path>

#### Setting the Message Header

- ▶ SET·/CTRL/HTTP/C1.Header=<header\_text>

#### Sending a Post Message

- ▶ CALL·/CTRL/HTTP/C1:post(<body\_text>)

#### Sending a Put Message

- ▶ CALL·/CTRL/HTTP/C1:put(<body\_text>)

### CEC Command Sending

#### Press&Release Commands

- ▶ CALL·/MEDIA/CEC/<port>:sendClick(<command>)

#### Further Commands

- ▶ CALL·/MEDIA/CEC/<port>:send(<command>)

#### Sending an OSD String

- ▶ SET·/MEDIA/CEC/<port>.OsdString=<text>
- ▶ CALL·/MEDIA/CEC/<port>:send(set\_osd)

#### Sending CEC Commands in Hex Format

- ▶ CALL·/MEDIA/CEC/<port>:sendHex(<hex\_code>)

#### Querying the Last Received CEC Message

- ▶ GET·/MEDIA/CEC/<port>.LastReceivedMessage

### Event Manager Basics

#### How to arrange an Event?

#### Setting a Condition by Specifying a Direct Path

- ▶ SET·/EVENTS/E<loc>.Condition=<expression>

#### Setting a Condition by Linking Another Condition

- ▶ SET·/EVENTS/E<loc>.Condition=<event\_nr>

**Setting a Condition by Linking Conditions**

- ▶ SET·/EVENTS/E<loc>.Condition=<event\_nr>&<event\_nr>&<event\_nr>&<event\_nr>

**Setting an Action by Specifying a Direct Path**

- ▶ SET·/EVENTS/E<loc>.Action=<expression>

**Setting an Action by Linking Another Action**

- ▶ SET·/EVENTS/E<loc>.Action=<event\_nr>

**Setting an Action by Linking a Macro**

- ▶ SET·/EVENTS/E<loc>.Action=<macro\_name>

**Event Manager Tool Kit****Setting the Delay**

- ▶ SET·/EVENTS/E<loc>.ConditionTimeout=<time>
- ▶ SET·/EVENTS/E<loc>.ConditionEndCheck=<true/false>
- ▶ SET·/EVENTS/E<loc>.ConditionTimeoutContinuous=<true/false>

**Setting the Name of the Event**

- ▶ SET·/EVENTS/E<loc>.Name=<string>

**Enabling/Disabling an Event**

- ▶ SET·/EVENTS/E<loc>.Enabled=<true/false>

**Triggering a Condition**

- ▶ CALL·/EVENTS/E<loc>.triggerCondition(1)

**Querying the Condition Counter**

- ▶ GET·/EVENTS/E<loc>.ConditionCount

**Querying the Condition Trigger Counter**

- ▶ GET·/EVENTS/E<loc>.ExternalConditionTriggerCount

**Testing an Action**

- ▶ CALL·/EVENTS/E<loc>.ActionTest(1)

**Variable-Management****Value Assignment**

- ▶ SET·/CTRL/VARS/V<loc>.Value=<value>

**Addition and Subtraction (Add Method)**

- ▶ CALL·/CTRL/VARS/V<loc>.add(<operand>;<min>;<max>)

**Addition and Subtraction (Cycle Method)**

- ▶ CALL·/CTRL/VARS/V<loc>.cycle(<operand>;<min>;<max>)

**Value Change with Intervals (Case)**

- ▶ CALL·/CTRL/VARS/V<loc>.case(<min> <max> <val>;)

**Scan and Store**

- ▶ CALL·/CTRL/VARS/V<loc>.scanf(<path>.<property>;<pattern>)

**Reformatting a Value**

- ▶ CALL·/CTRL/VARS/V<loc>.printf(<prefix>%s<postfix>)

**Ethernet Tool Kit****Device Filter Based on MAC Address**

- ▶ SET·/MANAGEMENT/MACFILTER.MACAddress<loc>=<MAC\_address>;<receive>;<send>;<name>

**Blocking the LW2 Control Port**

- ▶ SET·/MANAGEMENT/SERVICEFILTER.Lw2Enabled=<port\_mode>

**Blocking the HTTP Port**

- ▶ SET·/MANAGEMENT/SERVICEFILTER.HttpEnabled=<port\_mode>

**Blocking the HTTP Post Receiving**

- ▶ SET·/MANAGEMENT/SERVICEFILTER.HttpEnabled=<port\_mode>

**Powering on a Computer over Ethernet (Wake-on-LAN)**

- ▶ CALL·/MEDIA/ETHERNET:wakeOnLan(<MAC\_address>)

**Setting the Host Name**

- ▶ SET·/MANAGEMENT/NETWORK.HostName=<unique\_name>

**GPIO Port Settings****Setting the Direction of a GPIO Pin**

- ▶ SET·/MEDIA/GPIO/<gpio\_port>.Direction=<dir>

**Setting the Output Level of a GPIO Pin**

- ▶ SET·/MEDIA/GPIO/<gpio\_port>.Output=<value>

**Toggling the Level of a GPIO Pin**

- ▶ CALL·/MEDIA/GPIO/<gpio\_port>.toggle()

**USB Port Settings****USB Host Select**

- ▶ SET·/MEDIA/USB/USBSWITCH.HostSelect=<USB\_host>

**Power Switch Delay**

- ▶ SET·MEDIA/USB/USBSWITCH.DelayedSwitch=<delay\_status>

#### Host 5V Sense

- ▶ GET·/MEDIA/USB/USBSWITCH.<HostPc>

#### Device 5V Enable

- ▶ SET·/MEDIA/USB/USBSWITCH.<Device5vEnable>=<enable>

#### Querying the 5V Overcurrent Status of the Device

- ▶ GET·/MEDIA/USB/USBSWITCH.<deviceid>

### System Monitoring Commands

#### Querying Video Signal Presence

- ▶ GET·/MEDIA/VIDEO/<port>.SignalPresent

#### Querying the Connected Device (or Cable)

- ▶ GET·/MEDIA/VIDEO/<port>.Connected

#### Querying the Embedded Audio

- ▶ GET·/MEDIA/VIDEO/<port>.EmbeddedAudioPresent

#### Hotplug Detect

- ▶ GET·/MEDIA/VIDEO/<port>.Power5vIn

# 9

## Firmware Update

This chapter is meant to help customers perform firmware updates on our products by giving a few tips on how to start and by explaining the features of the Lightware Device Updater v2 (LDU2) software. The latest software and firmware pack can be downloaded from [www.lightware.com](http://www.lightware.com).

- ▶ INTRODUCTION
- ▶ PREPARATION
- ▶ RUNNING THE SOFTWARE
- ▶ THE UPDATING STEPS
- ▶ COMMAND LINE INTERFACE (CLI)
- ▶ CLI COMMANDS
- ▶ IF THE UPDATE IS NOT SUCCESSFUL

**ATTENTION!** While the firmware is being updated, the normal operation mode is suspended, as the device is switched to bootload mode. Signal processing is not performed. Do not interrupt the firmware update. If any problem occurs, reboot the device and restart the process.

## 9.1. Introduction

Lightware Device Updater v2 (LDU2) software is the second generation of the LFP-based (Lightware Firmware Package) firmware update process.

**DIFFERENCE:** This software can be used for uploading the packages with LFP2 extension only. LDU2 is not suitable for using LFP files, please use the LDU software for that firmware update.



## 9.2. Preparation

Most Lightware devices can be controlled over several interfaces (e.g. Ethernet, USB, RS-232). But the firmware can be updated usually over one dedicated interface, which is the Ethernet in most cases.

If you want to update the firmware of one or more devices, you need the following:

- LFP2 file,
- LDU2 software installed on your PC or Mac.

Both can be downloaded from [www.lightware.com/downloads](http://www.lightware.com/downloads).

Optionally, you can download the **release notes** file in HTML format.

### 9.2.1. About the Firmware Package (LFP2 File)

All the necessary tools and binary files are packed into the LFP2 package file. You only need this file to update your device.

- This allows the use of the same LFP2 package for different devices.
- The package contains all the necessary components, binary, and other files.
- The release notes is included in the LFP2 file, which is displayed in the window where you select the firmware package file in LDU2.

### 9.2.2. LDU2 Installation

**ATTENTION!** Minimum system requirement: 2 GB RAM. The minimum screen resolution is 1600x900.

**INFO:** The Windows and the Mac applications have the same look and functionality.

Download the software from [www.lightware.com/downloads](http://www.lightware.com/downloads).

### 9.2.3. LDU2 Installation

**ATTENTION!** Minimum system requirement: 2 GB RAM.

**INFO:** The Windows and the Mac applications have the same look and functionality.

Download the software from [www.lightware.com/downloads](http://www.lightware.com/downloads).

#### Installation Modes

Normal install	Snapshot install
Available for Windows, macOS and Linux	Available for Windows only
The installer can update only this instance	Cannot be updated
One updateable instance may exist for all users	Many different versions can be installed for all users

**ATTENTION!** Using the default Normal install is highly recommended.

**INFO:** If you have a previously installed version, you will be prompted to remove the old version before installing the new one.

#### Installation in case of Windows OS

Run the installer. If the User Account Control displays a pop-up message, click **Yes**.

Using the **Normal install** (default setting) is highly recommended.



#### Installation in case of macOS

Mount the DMG file by double clicking on it, and drag the LDU2 icon over the Applications icon to copy the program into the Applications folder. If you want to copy LDU2 into another location, just drag the icon over the desired folder.

**INFO:** This type of installer is equal to the **Normal install** of Windows.

**ATTENTION!** Please check the firewall settings on the macOS device. LDU2 needs to be added to the exceptions of the blocked softwares for proper operation.



#### Installation in case of Linux

**Step 1.** Download the **archive file** (tar.gz) from [www.lightware.com](http://www.lightware.com) and unpack it to a temp folder.

**Step 2.** Run the **install\_ldu2.sh** file in the temp folder. The script will install LDU2 into the following folder: HOME/.local/share/lightware/ldu2.

**Step 3.** Above folder will contain this file: **LightwareDeviceUpdaterV2.sh** that can be used to start LDU2.

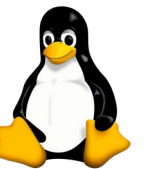

### 9.3. Running the Software

**DIFFERENCE:** Added support for firmware update from a host PC which is in another subnet as the device. The feature is available only from **firmware package v1.6.4b2**.

You have two options:

- **Starting the LDU2** by double-clicking on the shortcut/program file, or
- Double-clicking on an **LFP2 file**.

#### LDU2 Auto-Update

At startup, the software checks if a newer version is available on the web.

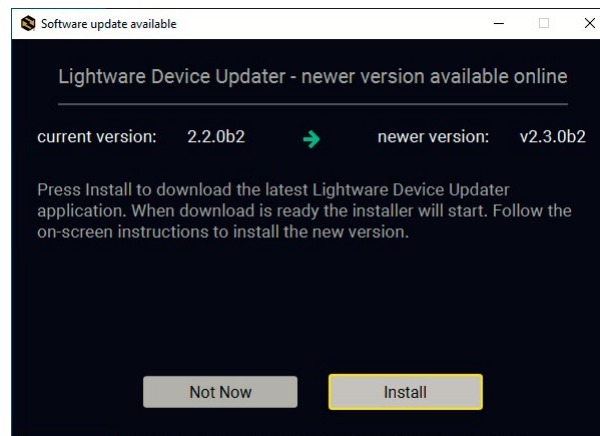

#### Main Screen

When the software is started by the shortcut, the device discovery screen appears. Press the **Search for devices** button to start finding the Lightware devices:

DISCOVER DEVICES

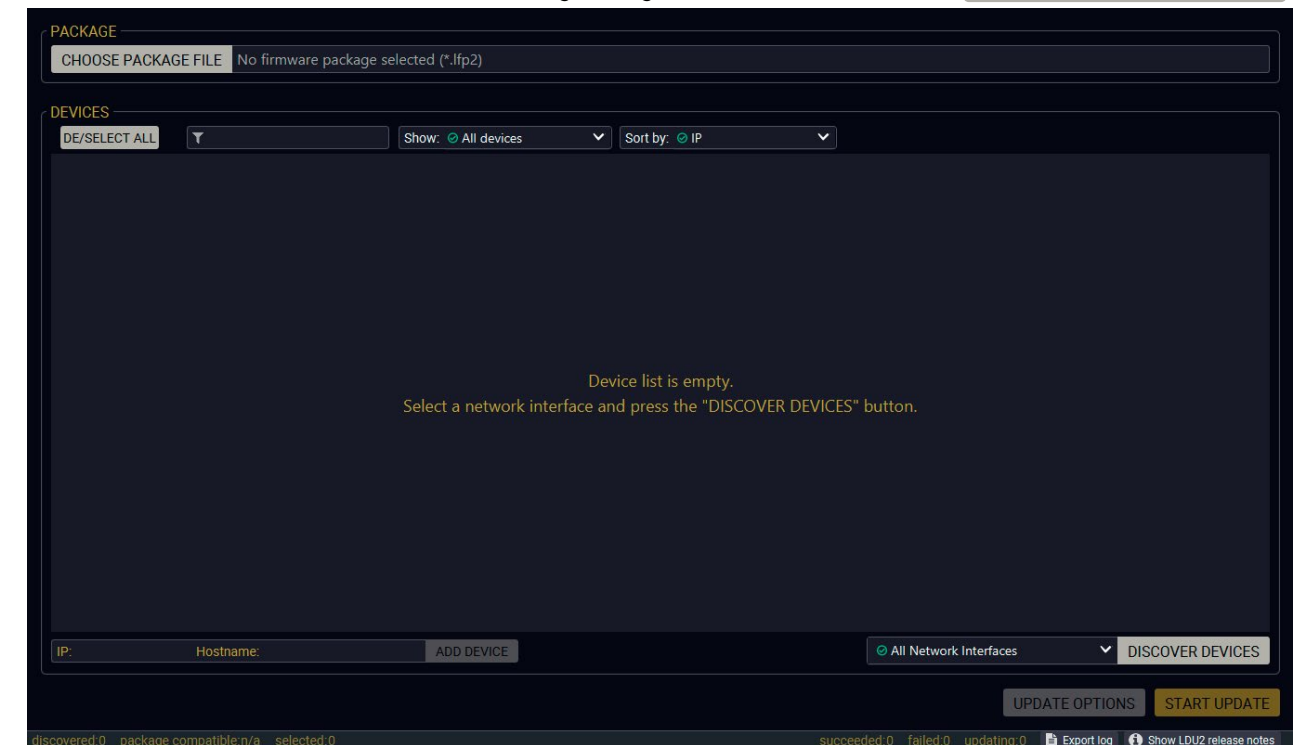

Devices may also be added manually by typing the IP address in the box near the bottom of the screen. From LDU2 version v2.16.1, manual addition of devices can also be done using the hostname.

**ATTENTION!** If the device cannot be added by the hostname, please use the IP address.

If you start the software by double-clicking on the LFP2 file, the firmware will be loaded. Press the **Search for devices** button; all the devices will be listed that are compatible with the selected firmware pack.

**INFO:** If you press the **Select firmware package** button, the release notes of the LFP2 file will be displayed in the right panel; see the [Step 1 – Select the Firmware Package](#) section.

## Device List





When the discovery has completed, the devices available on the network are listed in the application.

DEVICES	DE/SELECT ALL	Show: All devices	Sort by: IP
1. <input type="checkbox"/>	<b>UCX-4x3-H20</b> LW_UCX-4x3-H20_00007316	IP: 192.168.0.110 S/N: 00007316	PACKAGE: v1.3.0b1 FW: v1.3.0b1
2. <input type="checkbox"/>	<b>UMX-TPS-TX140K</b> LW_UMX-TPS-TX140K_00006363	IP: 192.168.0.113 S/N: 00006363	PACKAGE: v1.5.0b4 FW: v1.5.0b4
3. <input type="checkbox"/>	<b>UMX-HDMI-140-Plus</b> LW_UMX-HDMI-140-Plus_12345678	IP: 192.168.1.17 S/N: 12345678	PACKAGE: FW:
4. <input type="checkbox"/>	<b>MMX8x8-HDMI-4K-A</b> LW_MMX8x8-HDMI-4K-A_00005560	IP: 192.168.0.100 S/N: 00005560	PACKAGE: v1.3.4b2 FW: v1.3.3b2
5. <input type="checkbox"/>	<b>UBEX-MMU-X200</b> UBEX-MMU-X200	IP: 192.168.4.100 S/N: 86122857	PACKAGE: v1.5.0b2 FW: v1.4.0b3
6. <input type="checkbox"/>	<b>UCX-4x2-HC30</b> LW_UCX-4x2-HC30_00006872	IP: 192.168.4.149 S/N: 00006872	PACKAGE: v1.3.0b6 FW: v1.3.0b6

IP: Hostname: ADD DEVICE All Network Interfaces DISCOVER DEVICES UPDATE OPTIONS START UPDATE

discovered:10 package compatible:n/a selected:0 succeeded:0 failed:0 updating:0 Export log Show LDU2 release notes

### Legend of the Icons

-  **IP address editor** The IP address of the device can be changed in the pop-up window.
-  **Identify me** Clicking on the icon results in the front panel LEDs blinking for 10 seconds, which helps identify the device physically.
-  **Favorite device** The device has been marked, thus the IP address is stored. When a device is connected with that IP address, the star will be highlighted in that line.
-  **Further information available** Device is unreachable. Change the IP address using the front panel LCD menu or the IP address editor of the LDU2.
-  **Cleartext login enabled** The password-protection is enabled. You have to enter the password to perform the firmware update in the **Parameters** window or in the appearing window in the beginning of the update.

## 9.4. The Updating Steps

**ATTENTION!** While the firmware is being updated, the normal operation mode is suspended, as the device is switched to bootload mode. Signal processing is not performed. Do not interrupt the firmware update. If any problem occurs, reboot the unit and restart the process.

### Keeping the Configuration Settings

By default, device configuration settings are restored when the firmware update is finished. If factory reset has been chosen in the parameters window, all device settings will be erased. In the case of factory reset, you can save the settings of the device in the Lightware Device Controller software and restore it later.

The following flow chart demonstrates how this function works in the background.

#### Step 1. Create a backup

The current configuration of the device is being saved into a configuration backup file on your computer.

#### Step 2. Start the Update

The device reboots and starts in bootload mode (firmware update mode).

#### Step 3. Update

The CPU firmware is changed to the new one.

#### Step 4. Factory reset

All configuration settings are restored to the factory default values.

#### Step 5. Conversion / Restore

The firmware package checks the backup data before the restoration procedure, and if it is necessary, a conversion is applied to avoid incompatibility problems between the firmware versions. All configuration settings are restored to the device after the conversion.

**If the factory default option is selected in the Parameters window, the conversion / restoration procedure will not be performed!**

#### Step 6. Finish

Once the firmware update procedure is finished, the device reboots and is ready for use.

### Step 1 – Select the Firmware Package

Click on the **Choose Package File** button and navigate to the location where the LFP2 file was saved. When you click on the name of package, the preview of the release notes is displayed in the right panel.

**CHOOSE PACKAGE FILE**

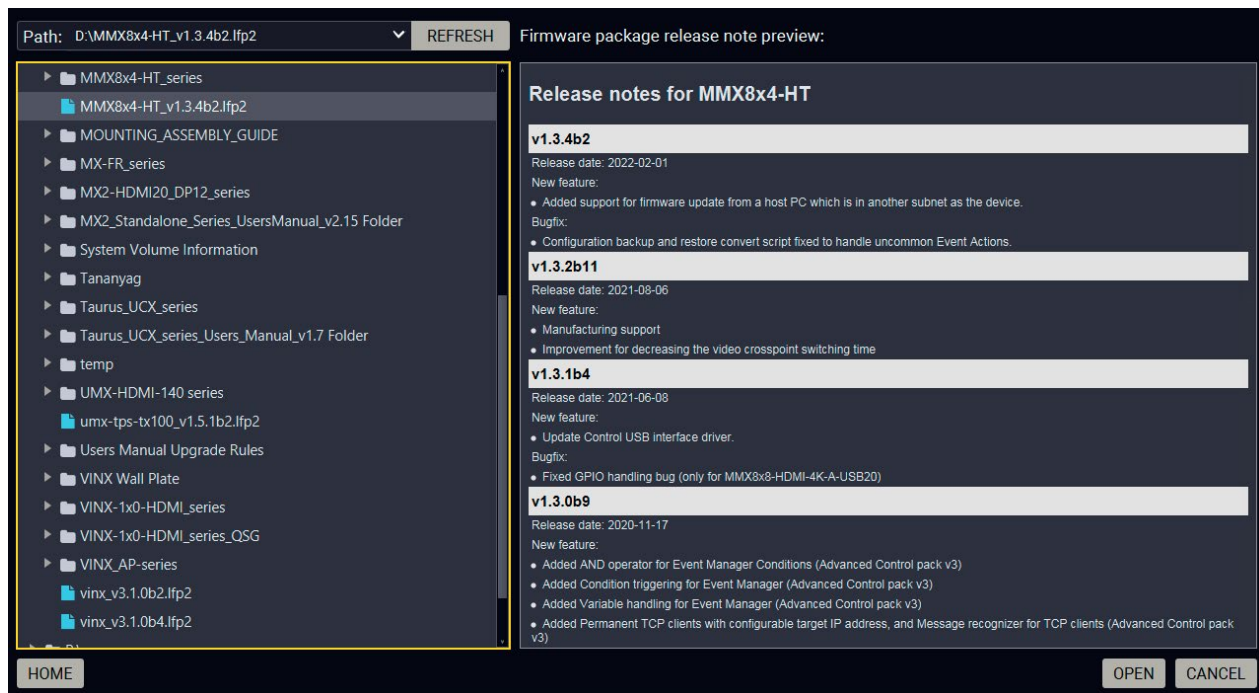

After the package file is loaded, the list is filtered to show the compatible devices only. The current firmware version of the device is highlighted in orange if it is different from the version of the package loaded.

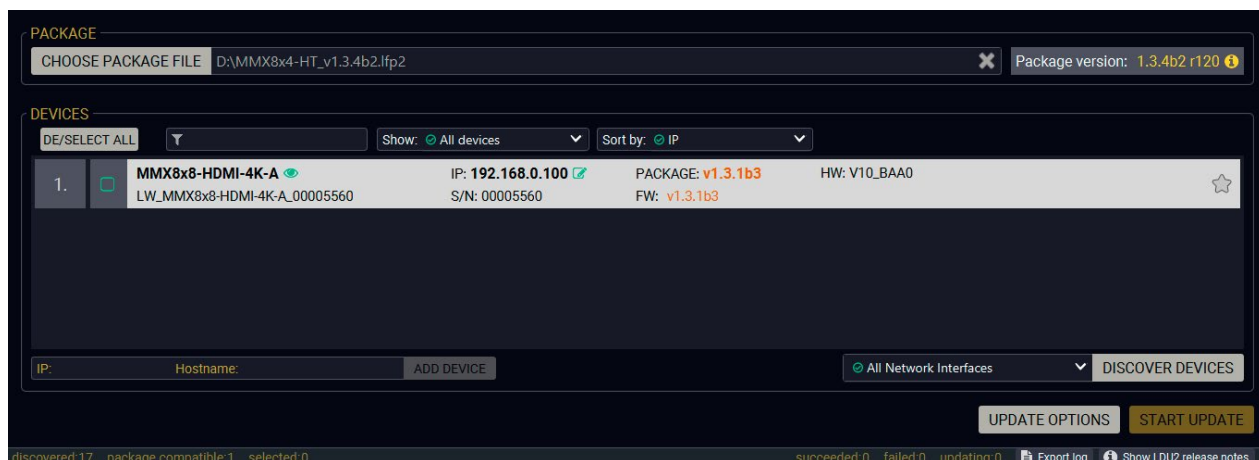

**INFO:** If you start the update by double-clicking on the LFP file, the screen above will be loaded right away.

### The Meaning of the Symbols



Show details

The log about the updating process of the device can be displayed in a new window.



Service mode

The device is in bootload mode. Backup and restore cannot be performed in this case.

### Step 2 – Select the desired devices for updating

Select the devices for updating; the selected line will be highlighted in green.

If you are not sure which device to select, press the **Identify me** button. It makes the front panel LEDs blink for 10 seconds. The feature helps find the device physically.

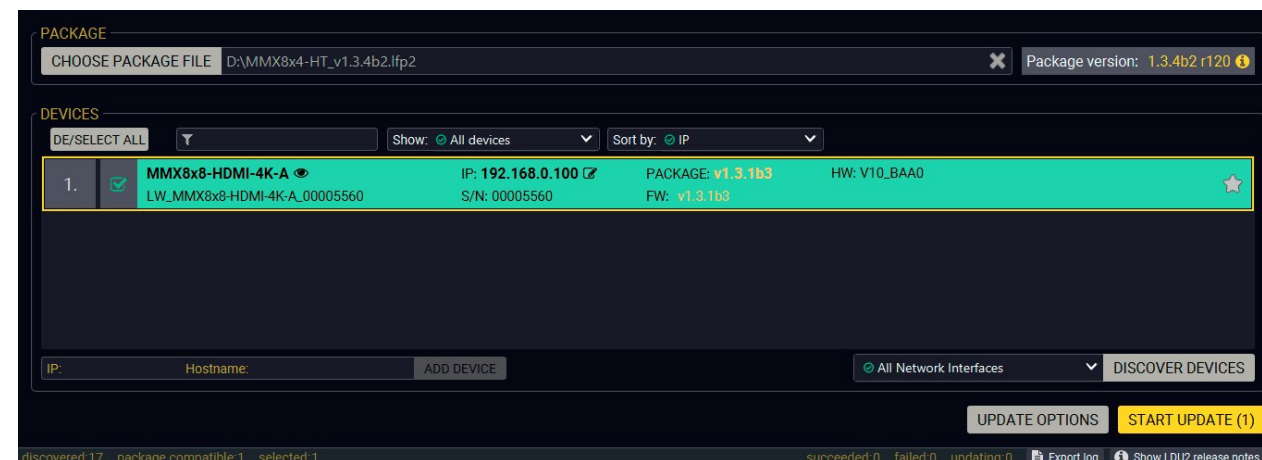

### Step 3 – Check the update parameters

**PARAMETERS**

Clicking on the **Parameters** button, special settings will be available like:

- Creating a backup about the configuration,
- Restoring the configuration or reloading the factory default settings after the firmware update.
- Uploading the default Miniweb (if available)
- Enter the password for the Cleartext login. #builtinweb #miniweb #web

**INFO:** The password entered here will be used for all selected devices where the Cleartext login is enabled. If the password is incorrect, a window will appear to ask for the correct one at each device during the update.

Please arrange the settings carefully.



#### Step 4 – Start the update and wait until it is finished

Click on the **Start Update** button to start the procedure. The status is shown in percent in the right side of the device line and the overall process in the progress bar at the bottom.

**START UPDATE (1)**

If the Cleartext login is enabled and you did not enter the password in the **Parameters** window (or it is incorrect), a window will appear to ask for the password at each device.

**ATTENTION!** The LCD menu is turned off during the firmware update process, you can get feedback about the status of the update via the LDUv2 software.

**INFO:** The device might reboot during the firmware update procedure.

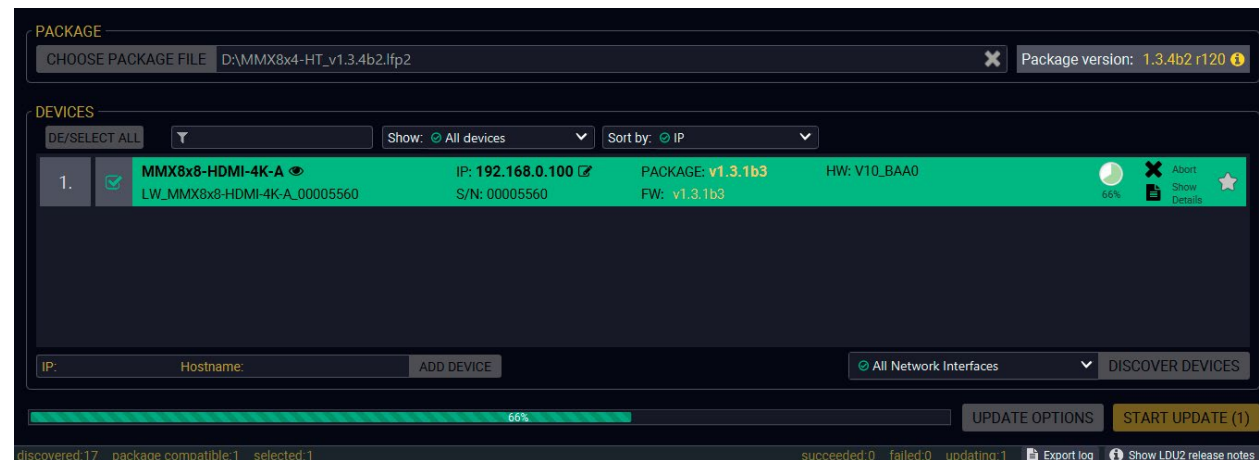

When the progress bar reaches 100% (**Done** is displayed at all devices), the update of all devices is finished successfully and a message appears; you can close the software.

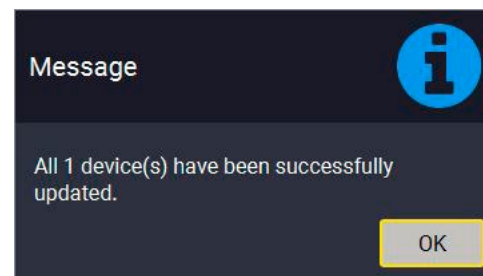

#### Step 5 – Wait until the unit reboots with the new firmware

Once the firmware update procedure is completed, the device is rebooted with the new firmware.

**ATTENTION!** The reboot takes a few minutes, please wait until the LCD screen becomes active again and during this period do not power off the matrix.

## 9.5. Command Line Interface (CLI)

**DIFFERENCE:** The Command Line Interface is available from LDU2 v2.9.0b9.

The CLI of the LDU2 software is a simple tool for creating scriptable device updates without needing human interactions. It allows batch updating with the same features that are available in case of GUI usage.

### 9.5.1. How to Run

#### Running under Windows® OS

The installer of LDU2 puts the following file into the installation folder:

**LightwareDeviceUpdaterV2\_CLI.cmd**

CLI is available by this file, the exe is not suitable for this purpose. Open a command line window to execute or test the features directly.

**Step 1.** Open an Explorer window where the cmd file is located, the default is:

c:\Program Files (x86)\Lightware\Lightware Device Updater V2\LightwareDeviceUpdaterV2\_CLI.cmd.

**Step 2.** Click on the address line (highlighted in blue in the picture), type **cmd.exe** and press enter. The command interpreter window of Windows is opened at the path of the LDU2 install folder.

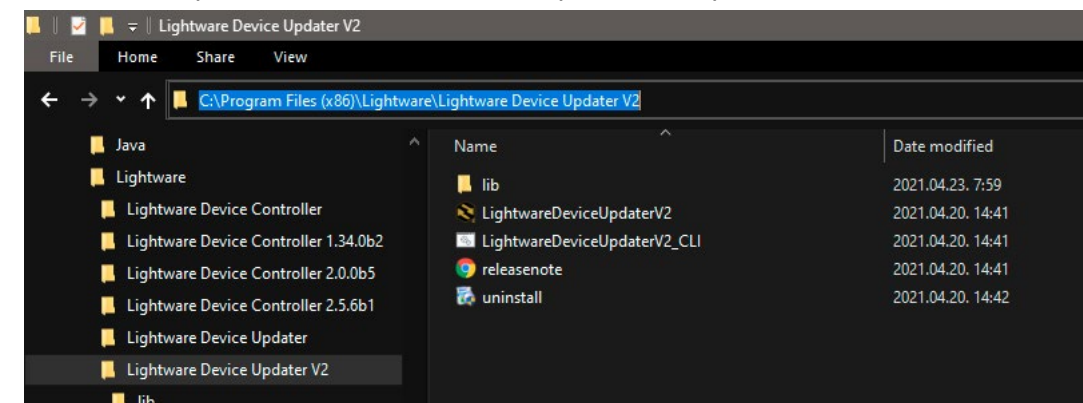

**Step 3.** Now you can use the **LightwareDeviceUpdaterV2\_CLI.cmd** file with the commands and options that are described in the coming sections:

#### Running under Linux

The Command Line Interface under Linux Operating Systems can be run by the following:

**LightwareDeviceUpdaterV2.sh.**

Running an update:

```
bash LightwareDeviceUpdaterV2.sh update --ip 172.24.5.27 --package ~/Downloads/mmx6x2-ht_v1.1.5b11.lfp2
```

The commands and options are the same under both Windows® and Linux. The following sections contain examples with **LightwareDeviceUpdaterV2\_CLI.cmd**.

### 9.5.2. How to Use

#### Command Structure

The commands can be run over CLI in the following way:

**LightwareDeviceUpdaterV2\_CLI.cmd [command] [options]**

**[Command]:** a certain command described in the coming sections; only one command can be run at a time

**[Options]:** mandatory and/or optional parameters of the command, if any. Optional parameters have a default value, which can be found at each affected command. You only have to define the parameter if you want to apply a different value. The **order of the options** is arbitrary.

#### Important Notes

- CLI is **case-sensitive** (including commands, options and other parameters).
- There is **no limit** regarding the number of the devices to update. At most, 20 devices are updated simultaneously; when one of them is finished, the following (21st) will be started automatically.
- If an update is failed, the IP address of the affected device(s) are listed at the end.

## 9.6. CLI Commands

INFO: The commands and options described in the following sections are the same under both Windows® and Linux. The examples contain **LightwareDeviceUpdaterV2\_CLI.cmd**.

#### About the Examples

- Sent command is in **blue**, response is in **grey**.
- If the response in practice is **longer than listed** in the example, this symbol can be seen: [...].

### 9.6.1. Help

The defined commands and options can be listed by the **help** command.

#### Command

**LightwareDeviceUpdaterV2\_CLI.cmd help**

#### Example

```
C:\Program Files (x86)\Lightware\Lightware Device Updater V2>LightwareDeviceUpdaterV2_CLI.cmd help
C:\Program Files (x86)\Lightware\Lightware Device Updater V2>lib\jre\bin\java.exe -jar lib\ldu2.jar help
Command line usage:
  Win: LightwareDeviceUpdaterV2_CLI.cmd [command] [options]
  Linux: LightwareDeviceUpdaterV2.sh [command] [options]

Commands:
  * help
  * version
  * update
  * deviceInfo
  * restore
  * packageOptions
[...]
```

### 9.6.2. LDU2 Version

The response shows the version of the LDU2 and the version of the Script API (the Application Programming Interface that is used by the LDU2 and the script).

#### Command

**LightwareDeviceUpdaterV2\_CLI.cmd version**

#### Example

```
C:\Program Files (x86)\Lightware\Lightware Device Updater V2>LightwareDeviceUpdaterV2_CLI.cmd version
C:\Program Files (x86)\Lightware\Lightware Device Updater V2>lib\jre\bin\java.exe -jar lib\ldu2.jar version
LDU2 version: 2.15.0b4
Script API version: 1.3.13
```

### 9.6.3. Check For New LDU2 Version

The following command can be used to check if an update of LDU2 is available. This is just a request, since the CLI is not suitable for handling the complete installer of the software.

#### Command

**LightwareDeviceUpdaterV2\_CLI.cmd checkForUpdates**

#### Example 1

```
c:\Program Files (x86)\Lightware\Lightware Device Updater V2>LightwareDeviceUpdaterV2_CLI.cmd checkForUpdates
C:\Program Files (x86)\Lightware\Lightware Device Updater V2>lib\jre\bin\java.exe -jar lib\ldu2.jar checkForUpdates
Current LDU2 version: 2.15.0b4
LDU2 is up-to-date
```

#### Example 2

```
c:\Program Files (x86)\Lightware\Lightware Device Updater V2>LightwareDeviceUpdaterV2_CLI.cmd checkForUpdates
c:\Program Files (x86)\Lightware\Lightware Device Updater V2>lib\jre\bin\java.exe -jar lib\ldu2.jar checkForUpdates
Current LDU2 version: 2.13.0b1
New version is available online: v2.15.0b4
Download URL: http://update.lightware.hu/ldu2/lwr/v2.15.0b4/install_LDU2_v2.15.0b4.exe
```

### 9.6.4. Device Info

The most important information about the selected device is displayed; see the example for more details.

#### Command

```
LightwareDeviceUpdaterV2_CLI.cmd deviceInfo [options]
```

#### Options

Option	Description	Required?
-i or --ip	List of IP addresses of devices to be updated	one of them is mandatory
-n or --hostName	List of host names of devices to be updated	
-v or --packageVersion	Shows installed package version only	optional

#### Example 1

```
C:\Program Files (x86)\Lightware\Lightware Device Updater V2>LightwareDeviceUpdaterV2_CLI.cmd deviceInfo --ip 192.168.0.100

C:\Program Files (x86)\Lightware\Lightware Device Updater V2>lib\jre\bin\java.exe -jar lib\ldu2.jar deviceInfo --ip 192.168.0.100
Product name: MMX8x8-HDMI-4K-A
IP address: 192.168.0.100
Serial number: 00005560
MAC address: a8:d2:36:00:55:60
Part number: 91310043
Device label: LW_MMX8x8-HDMI-4K-A_00005560
Package version: v1.3.4b2
CPU FW version: v1.3.3b2
HW version: V10_BAA0
Operation mode: Application mode
```

#### Example 2

```
C:\Program Files (x86)\Lightware\Lightware Device Updater V2>LightwareDeviceUpdaterV2_CLI.cmd deviceInfo --ip 192.168.0.100 --packageVersion

C:\Program Files (x86)\Lightware\Lightware Device Updater V2>lib\jre\bin\java.exe -jar lib\ldu2.jar deviceInfo --ip 192.168.0.100 --packageVersion
v1.3.4b2
```

### 9.6.5. Update

This command can be used to update the firmware of the devices.

#### Command

```
LightwareDeviceUpdaterV2_CLI.cmd update [options]
```

#### Options

Option	Description	Required?
-p or --package	The path of the firmware package file	yes
-i or --ip	List of IP addresses of devices to be updated	one of them is mandatory
-n or --hostName	List of host names of devices to be updated	
-b or --backupFolder	Folder to create device configuration backup at. Default: USER_HOME/.ldu2/backup	optional
-f or --factoryDefault	Apply factory reset during device update. Default: false	optional
-r or --reportProgress	Report update progress in percentage form. Default: false	optional
Package-specific options	Certain LFP2 packages have features which can be applied at this command; see the <a href="#">Cable Wiring Guide</a> section.	optional

**ATTENTION!** The configuration is restored automatically if the factory default option is not applied in the update command. In that case, there is no need to run the **restore** command after the update.

#### Example

```
C:\Program Files (x86)\Lightware\Lightware Device Updater V2>LightwareDeviceUpdaterV2_CLI.cmd update --ip 192.168.0.100 --package C:\Firmwares\MMX8x4-HT_v1.3.4b2.lfp2 --reportProgress

C:\Program Files (x86)\Lightware\Lightware Device Updater V2>lib\jre\bin\java.exe -jar lib\ldu2.jar update --ip 192.168.0.100 --package C:\Firmwares\MMX8x4-HT_v1.3.4b2.lfp2 --reportProgress
[2022-04-06 13:34:00.176] [ INFO] [ main] - Device IPs: [192.168.0.100]
[2022-04-06 13:34:01.968] [ INFO] [ main] - All selected devices are available over the network.
[2022-04-06 13:34:02.115] [ INFO] [ main] - All the selected devices are compatible with the specified package.
[2022-04-06 13:34:02.675] [ INFO] [ 192.168.0.100] - Script parameters: deviceIp: 192.168.0.100, forceNoBackup: false, factoryDefault: false, restoreFromBackup: true, backupFolder: C:/My_backup, skipPresetsAtRestore: false, ciscoRoomIntegration: false, uploadDefaultMiniWeb: false
[2022-04-06 13:34:02.680] [ INFO] [ 192.168.0.100] - Package version: 1.3.4b2
[2022-04-06 13:34:02.730] [ INFO] [ 192.168.0.100] - Login functionality is currently not enabled.
[2022-04-06 13:34:02.749] [ INFO] [ 192.168.0.100] - Creating backup of device settings...
[2022-04-06 13:34:05.302] [ INFO] [ 192.168.0.100] - Backup HTTP enable properties
[2022-04-06 13:34:06.898] [ INFO] [ 192.168.0.100] - HTTP and HTTP post have got enabled on port 80
[2022-04-06 13:34:07.032] [ INFO] [ 192.168.0.100] - No miniweb file is found on the device.
[2022-04-06 13:34:07.127] [ INFO] [ProgressReporter] - Progress: 5%
[2022-04-06 13:34:08.602] [ INFO] [ 192.168.0.100] - HTTP and HTTP post properties have got restored on port 80
[2022-04-06 13:34:10.197] [ INFO] [ 192.168.0.100] - HTTP and HTTP post have got enabled on port 80
[...]
```

The lines containing "ProgressReporter" can be enabled optionally. If it is enabled, the current state is displayed every 5 seconds.

### 9.6.6. Restore

Restores device configuration from a backup file.

**TIPS AND TRICKS:** This command can be used for uploading a configuration to numerous devices (aka Configuration cloning by CLI).

#### Command

```
LightwareDeviceUpdaterV2_CLI.cmd restore [options]
```

#### Options

Option	Description	Required?
-i or --ip	List of IP addresses of devices to be updated	one of them is mandatory
-n or --hostName	List of host names of devices to be updated	
-b or --backupFile	The path of the configuration backup file	yes
-k or --keepOriginalIp	Do not override the network settings of the device with the ones in the backup file. It comes in handy when multiple devices' configuration is being restored from a single backup file. Default: false	optional

**ATTENTION!** The configuration is restored automatically if the factory default option is not applied in the **update** command. In that case, there is no need to run the **restore** command after the update.

#### Example

```
c:\Program Files (x86)\Lightware\Lightware Device Updater V2>LightwareDeviceUpdaterV2_CLI.cmd restore --ip 192.168.0.100 --backupFile C:\mybackup.lw3 --keepOriginalIp

C:\Program Files (x86)\Lightware\Lightware Device Updater V2>lib\jre\bin\java.exe -jar lib\ldu2.jar restore --ip 192.168.0.100 --backupFile C:\My_backup\mybackup.lw3 --keepOriginalIp
[2022-04-06 14:24:43.719] [ INFO] [          main] - Executing configuration restore...
[2022-04-06 14:24:43.725] [ INFO] [          main] - Device IPs: [192.168.0.100]
```

**INFO:** The firmware package checks the backup data before the restoration procedure and if it is necessary, a conversion is applied to avoid incompatibility problems between the firmware versions. In that case, two backup files are created: the original and a new one with "\_converted" suffix. Using the last one for restoring is recommended.

### 9.6.7. Package Options

Shows package-specific update options.

#### Command

```
LightwareDeviceUpdaterV2_CLI.cmd packageOptions [options]
```

#### Options

Option	Description	Required?
-p or --package	The path of the firmware package file	yes

#### Example

```
C:\Program Files (x86)\Lightware\Lightware Device Updater V2>LightwareDeviceUpdaterV2_CLI.cmd packageOptions --package c:\Firmwares\MMX8x4-HT_v1.3.4b2.lfp2

C:\Program Files (x86)\Lightware\Lightware Device Updater V2>lib\jre\bin\java.exe -jar lib\ldu2.jar packageOptions --package C:\Firmwares\MMX8x4-HT_v1.3.4b2.lfp2
Backup and restore options:

    factoryDefault: if set to true device will reset to factory default settings after the upgrade process is finished, default: false
    restoreFromBackup: if true, no device configuration is restored from the backup created at the beginning of upgrade process (default: true)
    skipPresetsAtRestore: If true, Device presets will be skipped at restore. (default: false)
    backupFolder: folder to create configuration backup into
    ciscoRoomIntegration: if true, special configuration is uploaded to the device for Cisco room integration (default: false)

Login options:

    clearTextLoginPw: The login password used when updating devices. (It's cleartext password!)

Advanced backup and restore options:

    forceNoBackup: if true, no backup file will be created (default: false)
    uploadDefaultMiniWeb: If true, and no custom miniweb is present on the device, the default miniweb file will be uploaded. (default: false)
```

Package option example can be seen in the following section.

## 9.6.8. Complex Examples

### Example 1

The following options are applied:

- Firmware is updated
- Factory default settings are restored

```
C:\Program Files (x86)\Lightware\Lightware Device Updater V2>LightwareDeviceUpdaterV2_CLI.cmd update --ip
192.168.0.100 --factoryDefault --package c:\Firmwares\MMX8x4-HT_v1.3.4b2.lfp2

C:\Program Files (x86)\Lightware\Lightware Device Updater V2>lib\jre\bin\java.exe -jar lib\ldu2.jar update --ip
192.168.0.100 --factoryDefault --package C:\Firmwares\MMX8x4-HT_v1.3.4b2.lfp2
[2022-04-06 14:15:24.499] [ INFO] [          main] - Device IPs: [192.168.0.100]
[2022-04-06 14:15:26.226] [ INFO] [          main] - All selected devices are available over the network.
[2022-04-06 14:15:26.355] [ INFO] [          main] - All the selected devices are compatible with the specified
package.
[2022-04-06 14:15:26.910] [ INFO] [ 192.168.0.100] - Script parameters: deviceIp: 192.168.0.100, forceNoBackup:
false, factoryDefault: true, restoreFromBackup: false, backupFolder: C:/My_backup, skipPresetsAtRestore: false,
ciscoRoomIntegration: false, uploadDefaultMiniWeb: false
[2022-04-06 14:15:26.915] [ INFO] [ 192.168.0.100] - Package version: 1.3.2b11
[2022-04-06 14:15:26.951] [ INFO] [ 192.168.0.100] - Login functionality is currently not enabled.
[2022-04-06 14:15:28.535] [ INFO] [ 192.168.0.100] - HTTP and HTTP post have got enabled on port 80
[2022-04-06 14:15:28.537] [ INFO] [ 192.168.0.100] - Switching device into bootload mode...
[2022-04-06 14:15:41.907] [ INFO] [ 192.168.0.100] - Gathering UID information from device...
[2022-04-06 14:15:42.162] [ INFO] [ 192.168.0.100] - UID info - Device IP: 192.168.0.100 Product name:
MMX8x8-HDMI-4K-A Product part number: 91310043 Serial number: 00005560 Hardware version: V10_BAA0 MAC address:
A8:D2:36:00:55:60
[2022-04-06 14:15:42.406] [ INFO] [ 192.168.0.100] - Package version on device: 1.3.2b11 r120
[2022-04-06 14:15:42.418] [ INFO] [ 192.168.0.100] - Updating Firmware of the MCU...
[2022-04-06 14:15:42.659] [ INFO] [ 192.168.0.100] - [Mmx8x4-HT.bin]'s current version on device: 1.3.2b11 r80
[2022-04-06 14:15:42.660] [ INFO] [ 192.168.0.100] - [Mmx8x4-HT.bin]'s version in the package: 1.3.3b2 r80
[2022-04-06 14:16:09.766] [ INFO] [ 192.168.0.100] - [Mmx8x4-HT.bin]'s firmware version updated in FVS EEPROM.
[2022-04-06 14:16:09.767] [ INFO] [ 192.168.0.100] - Updating Firmware of the audio DSP...
[2022-04-06 14:16:10.008] [ INFO] [ 192.168.0.100] - [AduStorage.bin]'s current version on device: 1.0.0b7 r12
[2022-04-06 14:16:10.008] [ INFO] [ 192.168.0.100] - [AduStorage.bin]'s version in the package: 1.0.0b7 r12
[2022-04-06 14:16:40.631] [ INFO] [ 192.168.0.100] - [AduStorage.bin]'s firmware version updated in FVS EEPROM.
[2022-04-06 14:16:40.632] [ INFO] [ 192.168.0.100] - Updating Firmware of the VS10 RX...
[2022-04-06 14:16:40.871] [ INFO] [ 192.168.0.100] - [vs010_rx.bin]'s current version on device: 1.1.0b0 r0
[2022-04-06 14:16:40.871] [ INFO] [ 192.168.0.100] - [vs010_rx.bin]'s version in the package: 1.1.0b0 r1322
[2022-04-06 14:16:54.104] [ INFO] [ 192.168.0.100] - [vs010_rx.bin]'s firmware version updated in FVS EEPROM.
[2022-04-06 14:16:54.104] [ INFO] [ 192.168.0.100] - Updating Firmware of the VS10 TX...
[2022-04-06 14:16:54.344] [ INFO] [ 192.168.0.100] - [vs010_tx.bin]'s current version on device: 1.1.0b0 r0
[2022-04-06 14:16:54.344] [ INFO] [ 192.168.0.100] - [vs010_tx.bin]'s version in the package: 1.1.0b0 r1322
[2022-04-06 14:17:07.494] [ INFO] [ 192.168.0.100] - [vs010_tx.bin]'s firmware version updated in FVS EEPROM.
[2022-04-06 14:17:07.495] [ INFO] [ 192.168.0.100] - Updating Firmware of the VS100 RX...
[2022-04-06 14:17:07.734] [ INFO] [ 192.168.0.100] - [vs100_rx.bin]'s current version on device: 1.1.0b0 r0
[2022-04-06 14:17:07.735] [ INFO] [ 192.168.0.100] - [vs100_rx.bin]'s version in the package: 1.1.0b0 r63
[2022-04-06 14:17:20.980] [ INFO] [ 192.168.0.100] - [vs100_rx.bin]'s firmware version updated in FVS EEPROM.
[2022-04-06 14:17:20.981] [ INFO] [ 192.168.0.100] - Updating Firmware of the VS100 TX...
[... ]
[2022-04-06 14:17:40.194] [ INFO] [ 192.168.0.100] - Setting system information...
[2022-04-06 14:17:45.963] [ INFO] [ 192.168.0.100] - Starting application...
[2022-04-06 14:18:57.671] [ INFO] [ 192.168.0.100] - Done
```

All 1 update(s) finished successfully.

### Example 2

The following options are applied:

- Cleartext login password is applied
- Custom backup folder is set
- Current configuration is saved
- Firmware is updated and saved, configuration is restored

```
C:\Program Files (x86)\Lightware\Lightware Device Updater V2>LightwareDeviceUpdaterV2_CLI.cmd update --ip
192.168.0.100 --package c:\Firmwares\MMX8x4-HT_v1.3.4b2.lfp2 --backupFolder c:\My_backup

C:\Program Files (x86)\Lightware\Lightware Device Updater V2>lib\jre\bin\java.exe -jar lib\ldu2.jar update --ip
192.168.0.100 --package C:\Firmwares\MMX8x4-HT_v1.3.4b2.lfp2 --backupFolder C:\My_backup --clearTextLoginPw qwer1234
[2022-04-06 13:58:36.806] [ INFO] [          main] - Device IPs: [192.168.0.100]
[2022-04-06 13:58:38.399] [ WARN] [ pool-2-thread-1] - NetworkMask property is not available. Cannot determine whether
the device is on the same network or not. Device IP: 192.168.0.100
[2022-04-06 13:58:38.428] [ WARN] [ pool-2-thread-1] - Bonjour device builder error messages: [Could not get device
label property. IP address: 192.168.0.100]
[2022-04-06 13:58:38.454] [ INFO] [          main] - All selected devices are available over the network.
[2022-04-06 13:58:38.579] [ INFO] [          main] - All the selected devices are compatible with the specified
package.
[2022-04-06 13:58:39.146] [ INFO] [ 192.168.0.100] - Script parameters: deviceIp: 192.168.0.100, forceNoBackup:
false, factoryDefault: false, restoreFromBackup: true, backupFolder: C:\My_backup, skipPresetsAtRestore: false,
ciscoRoomIntegration: false, uploadDefaultMiniWeb: false
[2022-04-06 13:58:39.151] [ INFO] [ 192.168.0.100] - Package version: 1.3.4b2
[2022-04-06 13:58:39.201] [ INFO] [ 192.168.0.100] - Logged in successfully.
[2022-04-06 13:58:39.220] [ INFO] [ 192.168.0.100] - Creating backup of device settings...
[2022-04-06 13:58:41.755] [ INFO] [ 192.168.0.100] - Backup HTTP enable properties
[2022-04-06 13:58:43.426] [ INFO] [ 192.168.0.100] - HTTP and HTTP post have got enabled on port 80
[2022-04-06 13:58:43.521] [ INFO] [ 192.168.0.100] - No miniweb file is found on the device.
[2022-04-06 13:58:45.091] [ INFO] [ 192.168.0.100] - HTTP and HTTP post properties have got restored on port 80
[2022-04-06 13:58:46.656] [ INFO] [ 192.168.0.100] - HTTP and HTTP post have got enabled on port 80
[2022-04-06 13:58:46.658] [ INFO] [ 192.168.0.100] - Switching device into bootload mode...
[2022-04-06 13:59:00.036] [ INFO] [ 192.168.0.100] - Gathering UID information from device...
[2022-04-06 13:59:00.290] [ INFO] [ 192.168.0.100] - UID info - Device IP: 192.168.0.100 Product name: MMX8x8-HDMI-
4K-A Product part number: 91310043 Serial number: 00005560 Hardware version: V10_BAA0 MAC address: A8:D2:36:00:55:60
[2022-04-06 13:59:00.533] [ INFO] [ 192.168.0.100] - Package version on device: 1.3.4b2 r120
[2022-04-06 13:59:00.791] [ INFO] [ 192.168.0.100] - Updating Firmware of the MCU...
[2022-04-06 13:59:01.031] [ INFO] [ 192.168.0.100] - [Mmx8x4-HT.bin]'s current version on device: 1.3.2b11 r80
[2022-04-06 13:59:01.032] [ INFO] [ 192.168.0.100] - [Mmx8x4-HT.bin]'s version in the package: 1.3.3b2 r80
[2022-04-06 13:59:28.171] [ INFO] [ 192.168.0.100] - [Mmx8x4-HT.bin]'s firmware version updated in FVS EEPROM.
[2022-04-06 13:59:28.173] [ INFO] [ 192.168.0.100] - Updating Firmware of the audio DSP...
[... ]
[2022-04-06 14:00:58.574] [ INFO] [ 192.168.0.100] - Setting system information...
[2022-04-06 14:01:04.334] [ INFO] [ 192.168.0.100] - Starting application...
[2022-04-06 14:02:50.381] [ INFO] [ 192.168.0.100] - Restoring device settings from the following backup file: C:\
My_backup\backup_91310042_00005560_2022-04-06_13-58-40_converted.lw3 ...
[2022-04-06 14:04:01.822] [ INFO] [ 192.168.0.100] - Device settings have been restored
[2022-04-06 14:04:01.878] [ INFO] [ 192.168.0.100] - Resetting device...
[2022-04-06 14:04:05.077] [ INFO] [ 192.168.0.100] - Done
```

All 1 update(s) finished successfully.

### 9.6.9. Exit Codes

There is a return value in all cases when a command run is finished. Currently, three codes are defined:

Code	Displayed text	Description
0	N/A	The update performed successfully
1	Update error (ErrorCode:1)	The error happened during the update
2	CLI error (ErrorCode:2)	The error happened before starting the update

The error line contains further information about the error.

#### Querying the Exit Code under Windows®

```
c:\Program Files (x86)\Lightware\Lightware Device Updater V2\echo %errorlevel%
0
```

#### Querying the Exit Code under Linux

```
echo $?
0
```

If this value is queried after the update and it is 0, the update performed successfully.

## 9.7. If the Update is not successful

- Restart the process and try the update again.
- If the device cannot be switched to bootloader (firmware update) mode, you can do that manually as written in the User's manual of the device. Please note that backup and restore cannot be performed in this case.
- If the backup cannot be created for some reason, you will get a message to continue the process without backup or stop the update. A root cause can be that the desired device is already in bootloader (firmware update) mode, thus the normal operation mode is suspended and backup cannot be made.
- If an update is not successful, the **Export log** button becomes red. If you press the button, you can download the log file as a ZIP package, which can be sent to Lightware Support if needed. The log files contain useful information about the circumstances to find the root cause.





# 10

## Troubleshooting



















Usually, if the system seems not to transport the signal as expected, the best strategy for troubleshooting is to check signal integrity through the whole signal chain starting from source side and moving forward to receiver end.



















- ▶ [USE CASE STUDIES](#)
- ▶ [HOW TO SPEED UP THE TROUBLESHOOTING PROCESS?](#)

### Pictogram Legend













-  Section to connections/cabling.
-  Section to front panel operation.
-  Section to LDC software.
-  Section to LW2 protocol commands.
-  Section to LW3 protocol commands.

### 10.1. Use Case Studies

Symptom	Root cause	Action	Refer to
<b>Video signal</b>			
<b>No picture on the video output</b>	Device(s) not powered properly	Check the matrix and the other devices if they are properly powered; try to unplug and reconnect them.	 4.4
	Cable connection problem	Cables must fit very well, check all the connectors.	 5.1
	No incoming signal	No video signal is present on the HDMI input ports. Check the source device and the HDMI cables.	 4.2.1
	Not the proper video port is the active one	Check the video crosspoint settings.	 3.1.5
			 3.2.3
			 6.4
			 7.4.7
			 8.6.1
	Not the proper interface is the active one	If the source/display has several connectors, check whether the proper interface is selected.	
	Output port is muted	Check the mute state of the ports.	 3.1.2
			 6.5.1
			 7.4.4
			 6.6.2 8.7.13
Display is not able to receive the video format	Check the emulated EDID and select another (e.g. emulate the display's EDID on the input port).	 3.1.3	
		 6.10	
		 8.8	
HDCP is disabled	Enable HDCP on input port(s) of the matrix.	 3.1.2	
		 6.6.1	
		 8.7.9	

Symptom	Root cause	Action	Refer to
<b>Video signal</b>			
<b>Image is magenta colored</b>	Wrong colorspace was set	The sink expects RGB color spaced signal, but receives YCbCr. Check if the proper signal type was set on the port properties window of the outputs (DVI / HDMI / Auto), check the emulated EDIDs and select another one, or check the colorspace settings on the sink device.	 6.6.1
			 8.7.18
<b>Audio signal</b>			
<b>Not the corresponding audio sounds</b>	Wrong video channel is set on the crosspoint	Check the video crosspoint settings.	 3.1.5
			 6.4
			 7.4.7
			 8.6.1
<b>No audio sounds</b>	Not proper audio mode was set		 6.6.1
			 6.6.2
	Audio channel is muted or volume is too low.	Check the audio properties.	 8.9.1
			 3.1.2
			 6.9
	Signal type was set to DVI	Check the properties of the output port and set it to HDMI or Auto.	 8.9
			 3.1.2
			 6.6.2
DVI EDID is emulated	Check the EDID and select an HDMI EDID to emulate.	 8.7.18	
		 3.1.3	
		 6.10.2	
			 8.8



Symptom	Root cause	Action	Refer to	
<b>RS-232 signal</b>				
<b>Connected serial device cannot be controlled</b>	Cable connection problem	Check the connectors to fit well; check the wiring of the plugs.		5.1
	Serial settings are different	Check the port settings of the matrix and the connected serial device(s). Pay attention to link and/or local ports.	 	6.11.1 8.10
<b>Ethernet</b>				
<b>No LAN connection can be established</b>	IP address conflict	Change the IP address to a not reserved one or enable DHCP if DHCP server exists in the network.		3.1.1
				6.13.2
				7.5
				8.15.3
	Incorrect IP address is set (direct connect)	Restore the factory default settings (with fix IP).		3.1.1
			  	6.13.2 7.3.13 8.4.12
<b>Event Manager</b>				
<b>Action does not start, although condition is completed.</b>	Too much delay was set.	Check the delay setting on the event Event Editor window. Try it again with zero delay (do not forget to verify it with the Apply button).		6.11.6
	The event was not verified/ enabled.	Both Condition and Action (and optionally the Delay) need to be verified. Check if the Event is Enabled on the Events tab.		6.11.6

## 10.2. How to Speed Up the Troubleshooting Process?

Lightware’s technical support team is always working hard to provide the fastest support possible. Our team’s response time is one of the best in the industry, and in the toughest of cases we can directly consult with the hardware or software engineer who designed the product to get the information from the most reliable source.

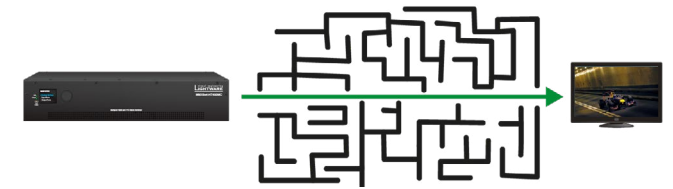

However, the troubleshooting process can be even faster... with your help.

There are certain pieces of information that push us in the right direction to find the root cause of the problem. If we receive most of this information in the first e-mail, or it is gathered at the time when you call us, then there is a pretty high chance that we will be able to respond with the final solution right away.

### This information is the following:

- Schematic (a pdf version is preferred, but a hand drawing is sufficient).
- Serial number(s) of the device(s) (it is either printed somewhere on the box or you can query it in the Device Controller software or on the built-in website).
- Firmware versions of the devices (please note that there may be multiple CPUs or controllers in the device and we need to know all of their firmware versions, a screenshot is the best option).
- Cable lengths and types (in our experience, it’s usually the cable).
- Patch panels, gender changers or anything else in the signal path that can affect the transmission.
- Signal type (resolution, refresh rate, color space, deep color).
- Emulated EDID(s) (please save them as a file and send it to us).
- Actions to take in order to re-create the problem (if we cannot reproduce the problem, it is hard for us to find the cause).
- Photo or video about the problem (‘image noise’ can mean many different things, it’s better if we see it too).
- Error logs from the Device Controller software.
- In the case of Event Manager issue, the event file and/or backup file from the Device Controller software.

The more of the information above you can give us, the better. Please send this information to the Lightware Support Team ([support@lightware.com](mailto:support@lightware.com)) to speed up the troubleshooting process.

# 11

## Technologies

The following sections contain descriptions and useful technical information on how the devices work in the background. The content is based on experiences and cases we met in the practice. These sections help understand features and technical standards like the following:

- ▶ [EDID MANAGEMENT](#)
- ▶ [HDCP MANAGEMENT](#)
- ▶ [PIXEL ACCURATE RECLOCKING](#)

## 11.1. EDID Management

### 11.1.1. Understanding the EDID

The Extended Display Identification Data (EDID) is the passport of display devices (monitors, TV sets, projectors). It contains information about the capabilities of the display, such as supported resolutions, refresh rates (these are called Detailed Timings), the type and manufacturer of the display device, etc.

After connecting a source to a display (DVI, HDMI, DP), the source reads out the EDID to determine the resolution and refresh rate of the image to be transmitted.

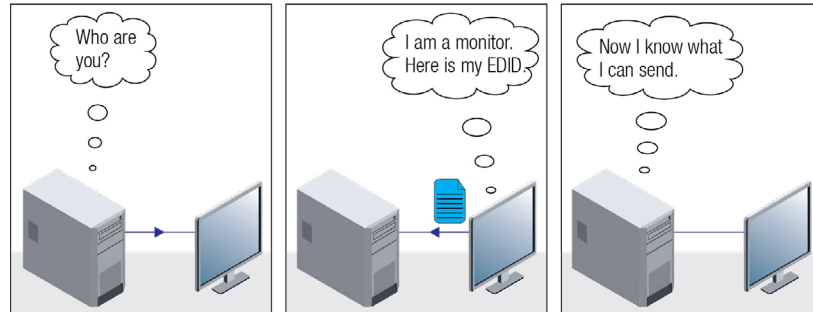

**EDID Communication**

Most DVI computer displays have 128-byte-long EDID structure. However, Digital Televisions and HDMI capable displays may have another 128 bytes, which is called E-EDID and is defined by CEA (Consumer Electronics Association). This extension contains information about additional Detailed Timings, audio capabilities, speaker allocation and HDMI capabilities. It is important to know that all HDMI capable devices must have CEA extension, but not all devices with CEA extension are HDMI capable.

#### Common Problems Related to EDID

**Problem:** “My system consists of the following: a computer, a Lightware device, a WUXGA (1920x1200) LCD monitor, and an SXGA (1280x1024) projector. I would like to see the same image on the monitor and the projector. What EDID should I choose on the Lightware device?”

**Solution:** If you want to see the image on both displays, you need to select the resolution of the smaller display (in this case SXGA), otherwise the smaller display may not show the higher resolution image.

**Problem:** “I have changed to a different EDID on an input port of the Lightware device to have a different resolution, but nothing happens.”

**Solution:** Some graphics cards and video sources read out the EDID only after power-up and later they do not sense that the EDID has been changed. You need to restart your source to make it read out the EDID again.

### 11.1.2. Advanced EDID Management

Each DVI sink (e.g. monitors, projectors, plasma displays, etc...) must support the EDID data structure. Source BIOS and operating systems are likely to query the sink using DDC2B protocol to determine what pixel formats and interface are supported. DVI standard uses EDID data structure to identify the monitor type and capabilities. Most DVI sources (VGA cards, set top boxes, etc.) will output DVI signal after accepting the connected sink's EDID information. In the case of EDID readout failure or missing EDID, the source will not output DVI video signal.

Lightware devices provide the Advanced EDID Management function that helps system integration. The built-in EDID Router can store and emulate factory pre-programmed- and User programmable EDIDs. The EDID of the attached monitors or projectors for each output are stored in a non-volatile memory. This way the EDID of a monitor is available when the monitor is unplugged or switched off.

Any EDID can be emulated on any input. An emulated EDID can be copied from the EDID router's memory (static EDID emulation), or from the last attached monitor's memory (dynamic EDID emulation). For example, the Lightware device can be set up to emulate a sink device, which is connected to one of the outputs. In this case, the EDID automatically changes, if the monitor is replaced with another display device (as long as it has a valid EDID).

EDID is independently programmable for all inputs without affecting each other. All inputs have their own EDID circuit.

**INFO:** The user is not required to disconnect the video cable to change an EDID as opposed to other manufacturer's products. EDID can be changed even if a source is connected to the input and powered ON.

**INFO:** When EDID has been changed, the router toggles the HOTPLUG signal for 2 seconds. Some sources do not sense this signal. In such cases, the source device must be restarted or powered OFF and ON again.

## 11.2. HDCP Management

Lightware Visual Engineering is a legal HDCP adopter. Several functions have been developed, which helps solve HDCP related problems. Complex AV systems often have both HDCP and non-HDCP components. The matrix allows transmitting both HDCP encrypted and unencrypted signals. The devices will be still HDCP compliant, as they will never output an encrypted signal to a non-HDCP compliant display device. If an encrypted signal is switched to a non-compliant output, a red screen alert or muted screen will appear.

### 11.2.1. Protected and Unprotected Content

Many video sources send HDCP protected signal if they detect that the sink is HDCP capable – even if the content is not copyrighted. This can cause trouble if an HDCP capable device is connected between the source and the display. In this case, the content cannot be viewed on non-HDCP capable displays and interfaces like event controllers. Rental and staging technicians often complain about certain laptops, which are always sending HDCP encrypted signals if the receiver device (display, matrix router, etc.) reports HDCP compliancy. However, HDCP encryption is not required all the time (e.g. computer desktop image), certain laptops still do that.

To avoid unnecessary HDCP encryption, Lightware introduced the HDCP enabling/disabling function: the HDCP capability can be disabled in the Lightware device. If HDCP is disabled, the connected source will detect that the sink is not HDCP capable, and turn off authentication.

### 11.2.2. Disable Unnecessary Encryption

#### HDCP Compliant Sink



All the devices are HDCP-compliant, no manual setting is required, both protected and unprotected contents are transmitted and displayed on the sink.

#### Not HDCP-compliant Sink 1.



Not-HDCP compliant sink is connected to the matrix. Some sources (e.g. computers) always send HDCP encrypted signals if the receiver device reports HDCP compliancy, however, HDCP encryption is not required all the time (e.g. computer desktop image). If HDCP is enabled in the matrix, the image will not be displayed on the sink.

Setting the HDCP parameter to Auto on the output port and disabling HDCP on the input port, the transmitted signal will not be encrypted if the content is not protected. Thus, non-HDCP compliant sinks will display non-encrypted signal.

#### Not HDCP-compliant Sink 2.



The layout is the same as in the previous case: non-HDCP compliant display device is connected to the matrix but the source would send protected content with encryption. If HDCP is enabled on the input port of the matrix, the source will send encrypted signal. The sink is not HDCP compliant, thus it will not display the video signal but red screen appears. If HDCP is disabled on the input port of the matrix, the source will not send the signal. The solution is to replace the display device with an HDCP-capable one.

### 11.3. Pixel Accurate Reclocking

Signal reclocking is an essential procedure in digital signal transmission. After passing the reclocking circuit, the signal becomes stable, jitter-free, and can be transmitted over more equipment like processors or event controllers. Without reclocking, sparkles, noise, and jaggies appear on the image.

Lightware's sophisticated Pixel Accurate Reclocking technology fixes more problems than general TMDS reclocking. It removes not only intra-pair skew, but inter-pair skew as well. The Pixel Accurate Reclocking circuit eliminates the following errors:

#### Intra-pair skew

Skew between the + and - wires within a differential wire pair (e.g. Data2- and Data2+). It's caused by different wire lengths or slightly different wire construction (impedance mismatch) in the DVI cable. It results in jitter.

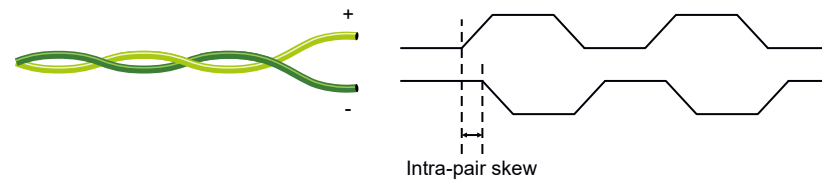

#### Inter-pair skew

Skew between two differential wire pairs in a cable. It is caused by different wire pair lengths or different number of twists in the DVI cable. Too much inter-pair skew results in color shift in the picture or sync loss.

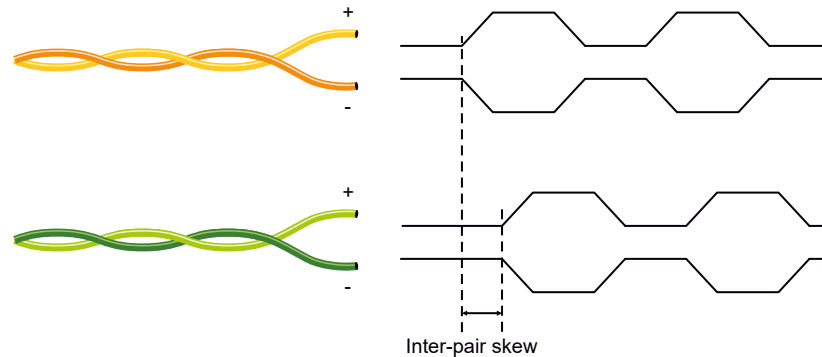

#### Jitter

Signal instability in the time domain. The time difference between two signal transitions should be a fixed value, but noise and other effects cause variations.

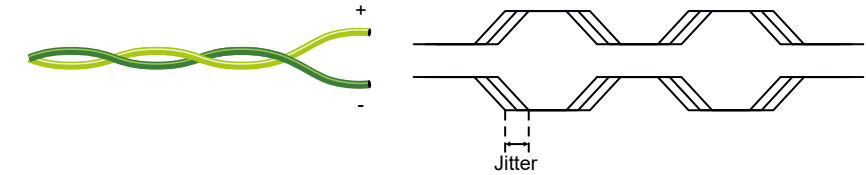

#### Noise

Electromagnetic interference between other electronic devices such as mobile phones, motors, etc. and the DVI cable are coupled onto the signal. Too much noise results in increased jitter.

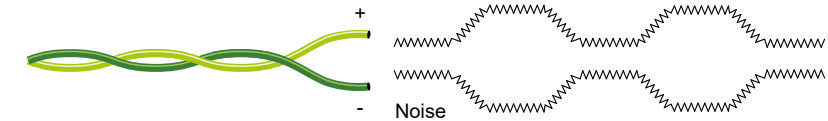

# 12

## Appendix

Tables, drawings, guides, and technical details as follows

- ▶ SPECIFICATIONS
- ▶ MECHANICAL DRAWINGS
- ▶ FACTORY DEFAULT SETTINGS
- ▶ CONTENT OF THE BACKUP FILE
- ▶ FLOWCHART OF AUTOSELECT MODES
- ▶ PORT NUMBERING
- ▶ CONDITIONS IN THE WIZARD TAB OF THE EVENT MANAGER
- ▶ ACTIONS IN THE WIZARD TAB OF THE EVENT MANAGER
- ▶ **HASHTAG KEYWORD LIST**
- ▶ FIRMWARE RELEASE NOTES
- ▶ APPLIED PORTS (NETWORK SETTINGS)
- ▶ FACTORY EDID LIST
- ▶ CABLE WIRING GUIDE
- ▶ FURTHER INFORMATION

## 12.1. Specifications

### General

Compliance	CE, UKCA, UL
EMC (emission)	EN 55032:2015+A1:2020
EMC (immunity)	EN 55035:2017+A11:2020
RoHS	EN 63000:2018
Electrical safety	EN 62368-1:2020
Warranty	3 years
Operating temperature	0 to +50°C (+32 to +122°F)
Storage temperature	-30 to +80°C (-22 to 176°F)
Operating humidity	10% to 90%, non-condensing
Cooling	by cooling fans, air flows from front to rear

### Power

Power supply option	Built-in PSU
Supported power source	100-240 V AC; 50~60 Hz

### MMX8x8-HDMI-4K-A

Power consumption (min/max)	15.5/34.6W
Heat dissipation (min/max)	53 BTU/h, 118 BTU/h

### MMX8x8-HDMI-4K-A-USB20

Power consumption (min/max)	15.5/45.3W
Heat dissipation (min/max)	53 BTU/h, 155 BTU/h

### Enclosure

Rack mountable	Yes, 2U High (rack ears supplied)
Enclosure material	1 mm steel
Dimensions in mm	442 (482*) W x 87.8 H x 300 D
Dimensions in inch	17.4 (18.9*) W x 3.45 H x 11.8 D
Weight - MMX8x8-HDMI-4K-A	4.5 kg
Weight - MMX8x8-HDMI-4K-A-USB20	4.6 kg
Front panel buttons	Yes
Display	LCD

\* with rack-mounting ears

### HDMI Input/Output Ports

Connector type	19-pole HDMI Type A receptacle
A/V standard	DVI 1.0, HDMI 1.4
HDCP compliance	HDCP 1.4
Color space	RGB, YCbCr
Video delay	0 frame
Supported resolutions at 8 bits/color *	3840x2160@30Hz RGB 4:4:4; 3840x2160@60Hz YCbCr 4:2:0; 1920x1080@120 Hz, 24 bit RGB 4:4:4
Reclocking	Pixel Accurate Reclocking
3D support	yes
Audio formats	2 channel PCM Stereo, 8 channel PCM
Input cable equalization	Yes, +12dB fixed

\* All standard VESA, CEA and other custom resolutions up to 300MHz (HDMI1.4) are supported.

### EDID management

EDID emulation	yes, advanced EDID management
EDID memory	50 factory presets, 20 programmable
Supported standard	EDID v1.3

### Analog audio input

Connector type	5-pole Phoenix connector
Audio formats	2-ch PCM
Sampling frequency	48 kHz
Maximum input level	+0 dBu, 0.77 Vrms, 2.19 Vpp
Signal transmission	Balanced / unbalanced signal
Balance	0 - 100 (50 = center)
Gain	0 dB - 6 dB

### Analog audio output

Connector type	3.5 mm TRS (1/8" jack) / 5-pole Phoenix connector
Audio formats	2-ch PCM
Sampling frequency	48 kHz
Volume	-78 dB - 0 dB
Balance	0 - 100 (50 = center)
Nominal Differential Output Level @ 0 dB Gain	+4 dBu
Nominal Differential Output Level @ 3 dB Gain	+7 dBu

**Control Ethernet port**

Connector type	Locking RJ45
Ethernet data rate	10/100Base-T, full duplex with autodetect
Power over Ethernet (PoE)	Not supported

**RS-232 port**

Connector type	3-pole Phoenix connector
Baud rates	between 4800 and 115200 baud
Data bits	8 or 9
Parity	None / Odd / Even
Stop bits	1 / 1.5 / 2
Output voltage: Low level	3 - 15V
Output voltage: High level	-15V - 3V

**TTL Serial port**

Connector type	2-pole Phoenix connector
Logic low level	0 - 0.25V
Logic high level	4.75 - 5.0V

**Infrared port**

Connector type	2-pole Phoenix connector
Connector type	3.5 mm TS (approx. 1/8" jack)
Output signal	modulated (38kHz) / not modulated (baseband)

**GPIO**

Connector type	8-pole Phoenix connector
Number of configurable pins	6
Port direction	Input or output
Input voltage: Low level	0 - 0,8 V
Input voltage: High level	2 - 5 V
Output voltage: Low level	0 - 0,5 V
Output voltage: High level	4.5 - 5 V
Max. current: Low level	30 mA
Max. current: High level	18 mA
Total available current	180 mA

INFO: Specifications are subject to change without notice.

**12.2. Mechanical Drawings**

All models have the same size.

Dimensions are in mm.

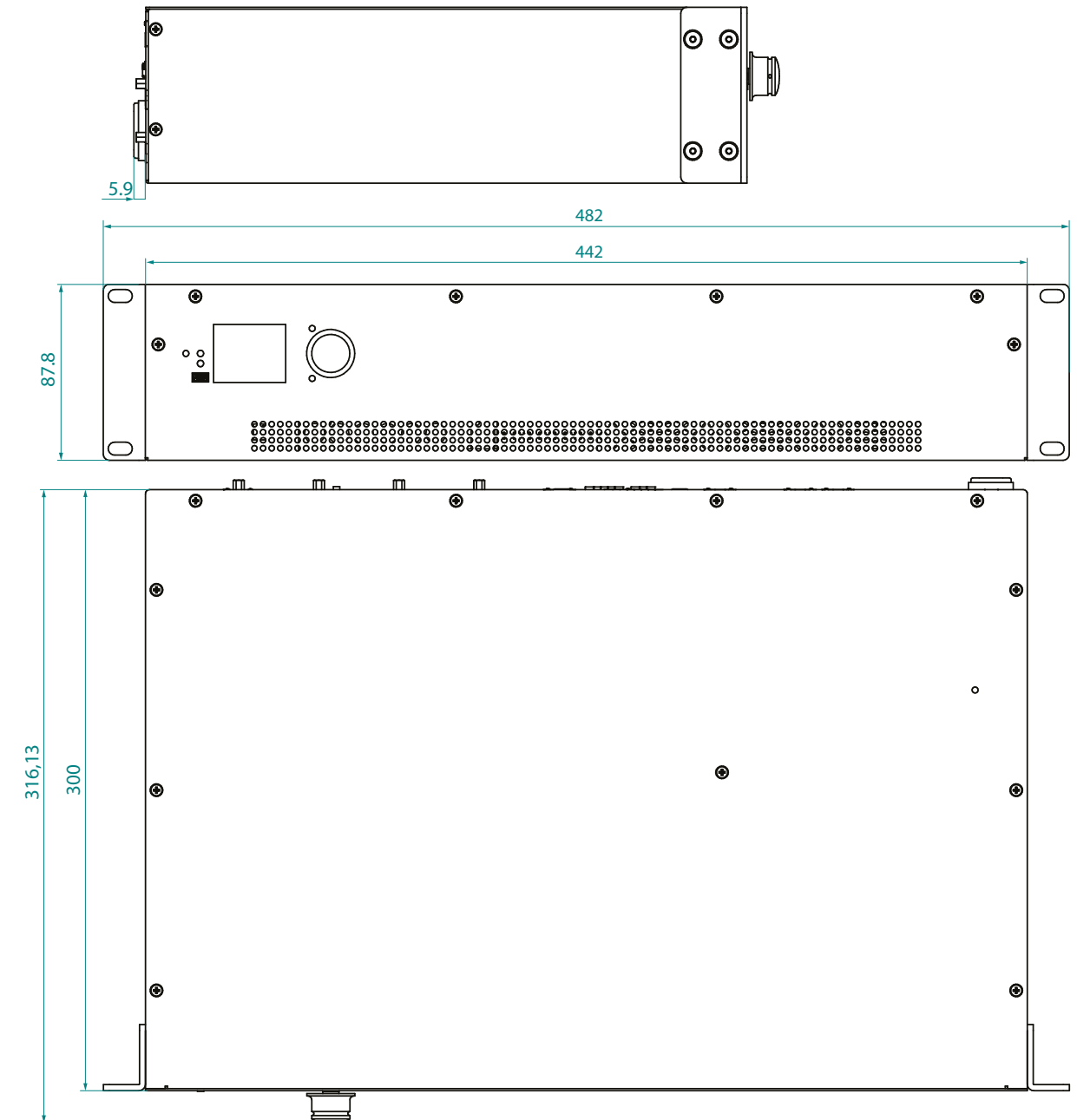



### 12.3. Factory Default Settings

Network Settings	
Parameter	Setting/Value
IP address	192.168.0.100
Subnet mask	255.255.255.0
Static gateway	192.168.0.1
LW2 Port number	10001
LW3 Port number	6107
HTTP Port number	80
DHCP	disabled
Video Port Settings	
Parameter	Setting/Value
HDCP – on input ports	Enabled
HDCP – on output ports	Auto
Output signal type	Auto
Power 5V mode	Auto
No sync screen mode/ color/ resolution	Off/ Bar/ 480p
Crosspoint state	I1 on all outputs
Audio source	HDMI audio passthrough
Autoselect	Disabled
Emulated EDID	F47 - Factory (1920x1080@60Hz HDMI)
Serial Settings	
Parameter	Setting/Value
Control protocol	LW2
Port number	8001, 8002, 8003, 8004
Baud rate / Databits / Parity / Stopbits	57600 / 8 / No / 1
Operation mode of RS-232 ports	CI (Command Injection)
Operation mode of IR/TTL ports	CI (Command Injection)
Operation mode of TPS ports	Control
IR Settings	
Parameter	Setting/Value
Operation mode	CI (Command Injection)

Port number	9001, 9002, 9003, 9004
GPIO Settings <sup>1</sup>	
Parameter	Setting/Value
Direction	Input
Input level	High
USB Settings <sup>1</sup>	
Parameter	Setting/Value
Selected USB Host (USB-B port)	PC1
5V Enabled on USB Device (USB-A ports 1-4)	Enable

<sup>1</sup> In the MMX8x8-HDMI-4K-A-USB20 model.

## 12.4. Content of the Backup File

The backup file contains numerous settings and parameters saved from the device. When the file is uploaded to a device, the following will be overwritten:

### Network settings

- DHCP status (enable / disable)
- Static IP address, Network mask, Gateway address
- MAC filter allowlist, Port blocking settings
- TCP client settings (/CTRL/TCP)

### Video ports settings

- Port name
- Port status (Lock/Unlock/Mute/Unmute, Autoselect settings)
- Crosspoint state
- HDCP status (enable / disable), Test pattern settings, Signal type, HDCP mode, PWR5V mode

### Audio settings (for I/O audio ports)

- Audio mode
- Mute, Volume, Balance, Gain

### RS-232 settings

- Port name
- Rs232Mode (Command injection / Control / Disconnect)
- Command injection status (enable / disable)
- Command injection port number
- Baud rate, Data bits, Parity, Stopbits, Control protocol

### IR settings

- Port name
- Port status (enable / disable)
- Command injection status (enable / disable)
- Command injection port number

### Ethernet settings

- Port name, Port status (enable / disable)

### GPIO settings <sup>1</sup>

- Port name, Direction, Input level

### USB Settings <sup>1</sup>

- Host select
- Power switch delay
- 5V enable on the device

### Other settings

- User EDID data
- Emulated EDID list
- Event manager: All Events' settings (1-100)
- All Presets' settings (1-6)
- Device label
- Rotary direction, Display brightness, Control lock
- Values of the variables

<sup>1</sup> In the MMX8x8-HDMI-4K-A-USB20 model.

### 12.5. Flowchart of Autoselect Modes

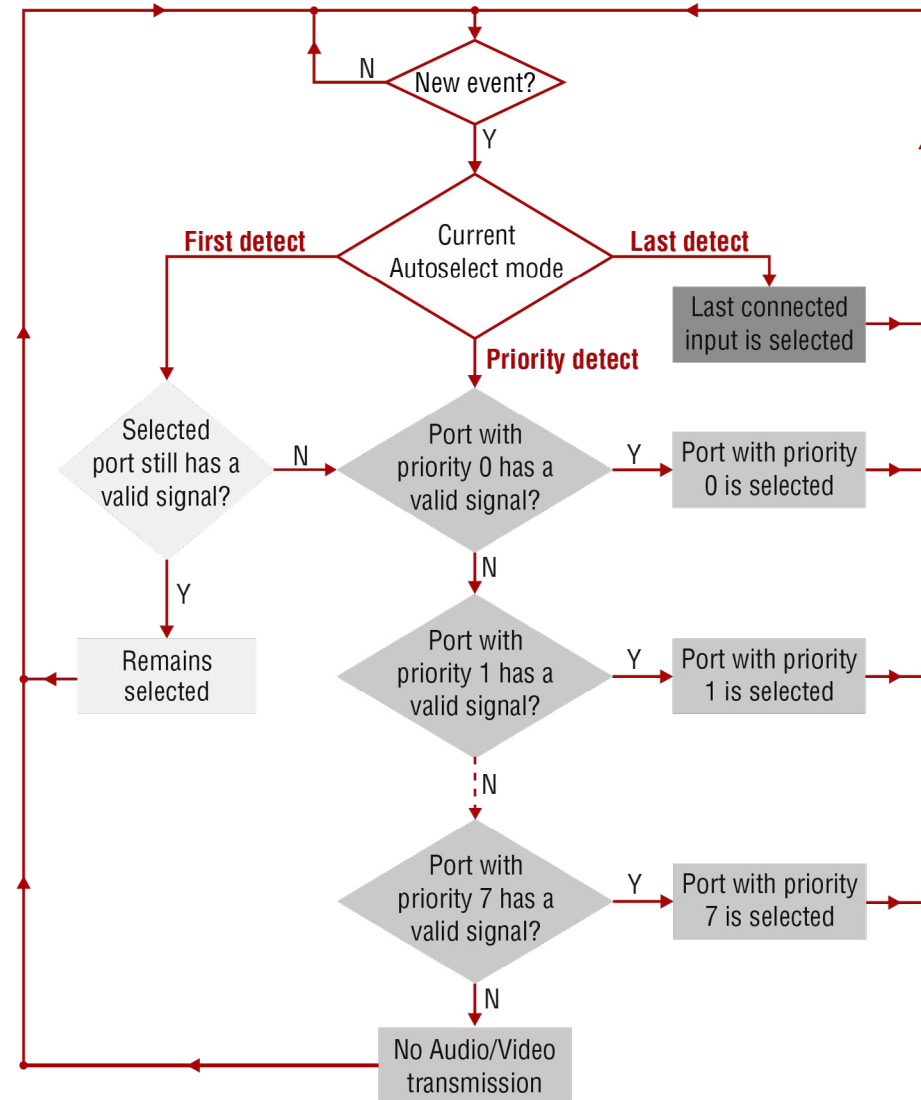

## 12.6. Port Numbering

### 12.6.1. MMX8x8-HDMI-4K-A

#### Audio/Video Ports

Port name	Video port nr. (LW2)	Video port nr. (LW3)	Emulated EDID memory	Audio port nr. (LW2)	Audio port nr. (LW3)
HDMI IN 1	01	I1	F47	-	I1
HDMI IN 2	02	I2	F47	-	I2
HDMI IN 3	03	I3	F47	-	I3
HDMI IN 4	04	I4	F47	-	I4
HDMI IN 5	05	I5	F47	-	I5
HDMI IN 6	06	I6	F47	-	I6
HDMI IN 7	07	I7	F47	-	I7
HDMI IN 8	08	I8	F47	-	I8
HDMI OUT 1	01	O1	-	-	O1
HDMI OUT 2	02	O2	-	-	O2
HDMI OUT 3	03	O3	-	-	O3
HDMI OUT 4	04	O4	-	-	O4
HDMI OUT 5	05	O5	-	-	O5
HDMI OUT 6	06	O6	-	-	O6
HDMI OUT 7	07	O7	-	-	O7
HDMI OUT 8	08	O8	-	-	O7

#### RS-232 Ports

Port name	Port nr. (LW2 / LW3)	Command injection port nr.
Uart 1	P1	8001
Uart 2	P2	8002
Uart3 Mixed	P3	8003
Uart4 Mixed	P4	8004

#### Ethernet

Port name	Port nr. (LW3)
CPU	P1
Control	P2

### 12.6.2. MMX8x8-HDMI-4K-A-USB20

#### Audio/Video Ports

Port name	Video port nr. (LW2)	Video port nr. (LW3)	Emulated EDID memory	Audio port nr. (LW2)	Audio port nr. (LW3)
HDMI IN 1	01	I1	F47	-	I1
HDMI IN 2	02	I2	F47	-	I2
HDMI IN 3	03	I3	F47	-	I3
HDMI IN 4	04	I4	F47	-	I4
HDMI IN 5	05	I5	F47	-	I5
HDMI IN 6	06	I6	F47	-	I6
HDMI IN 7	07	I7	F47	-	I7
HDMI IN 8	08	I8	F47	-	I8
HDMI OUT 1	01	O1	-	-	O1
HDMI OUT 2	02	O2	-	-	O2
HDMI OUT 3	03	O3	-	-	O3
HDMI OUT 4	04	O4	-	-	O4
HDMI OUT 5	05	O5	-	-	O5
HDMI OUT 6	06	O6	-	-	O6
HDMI OUT 7	07	O7	-	-	O7
HDMI OUT 8	08	O8	-	-	O7

#### RS-232 Ports

Port name	Port nr. (LW2 / LW3)	Command injection port nr.
Uart 1	P1	8001
Uart 2	P2	8002
Uart3 Mixed	P3	8003
Uart4 Mixed	P4	8004

## 12.7. Conditions in the Wizard Tab of the Event Manager

### Video Category

Condition		
Expression	HDMI-4K-A Ports	HDMI-4K-A-USB20
Signal is detected on a port	I1-I8; O1-O8	I1-I8; O1-O8
Signal is not detected on a port	I1-I8; O1-O8	I1-I8; O1-O8
Signal type change to DVI	I1-I8; O1-O8	I1-I8; O1-O8
Signal type change to HDMI	I1-I8; O1-O8	I1-I8; O1-O8
Signal type changes to Undefined (no signal)	I1-I8; O1-O8	I1-I8; O1-O8

### Audio Category

Condition		
Expression	HDMI-4K-A Ports	HDMI-4K-A-USB20
Signal is detected on a port	I1-I8; O1-O8	I1-I8; O1-O8
Signal is not detected on a port	I1-I8; O1-O8	I1-I8; O1-O8
Signal type change to PCM	I1-I8; O1-O8	I1-I8; O1-O8
Signal type change to Compressed	I1-I8; O1-O8	I1-I8; O1-O8
Signal type change to HBR	I1-I8; O1-O8	I1-I8; O1-O8
Signal type changes to Undefined (no signal)	I1-I8; O1-O8	I1-I8; O1-O8

### GPIO Category

Condition	
Expression	HDMI-4K-A-USB20
State changes to 'High'	P1-P6
State changes to 'Low'	P1-P6

## 12.8. Actions in the Wizard Tab of the Event Manager

### Video Category

Action				
Expression	Parameters HDMI-4K-A		Parameters HDMI-4K-A-USB20	
Switch input to output	I1-I8	O1-O8	I1-I8	O1-O8
Enable autoselect on output	O1-O8		O1-O8	
Disable autoselect on output	O1-O8		O1-O8	
Load crosspoint preset	Preset1 - Preset8		Preset1 - Preset8	
Mute input	I1-I8		I1-I8	
Mute output	O1-O8		O1-O8	
Unmute input	I1-I8		I1-I8	
Unmute output	O1-O8		O1-O8	

### RS-232 Category

Action			
Expression	HDMI-4K-A Ports	HDMI-4K-A-USB20 Ports	Parameter
Send RS-232 message	P1-P4	P1-P4	Message

### Infra Category

Action			
Expression	HDMI-4K-A Ports	HDMI-4K-A-USB20 Ports	Parameters
Send pronto hex code	D1-D4	D1-D4	Pronto hex

**Ethernet Category**

Action		
Expression	HDMI-4K-A-USB20 Parameters	HDMI-4K-A Parameters
Send TCP command	Message, IP address, Port number	
Send UTP command	Message, IP address, Port number	

INFO: The maximum length of the code can be 184 characters (184bytes).

**EDID Category**

Action				
Expression	Parameters HDMI-4K-A		Parameters HDMI-4K-A-USB20	
Switch EDID	F1-F149 D1-D8 U1-U24	E1-E8	F1-F149 D1-D8 U1-U24	E1-E8

**GPIO Category**

Action	
Expression	HDMI-4K-A-USB20 Ports
Open contact on relay	P1-P4
Close contact on relay	P1-P4
Toggle contact on relay	P1-P4

## 12.9. Hashtag Keyword List

This user's manual contains keywords with hashtags (#) to help you find the relevant information as quick as possible.

The format of the keywords is the following:

#<keyword>

The usage of the keywords: use the **Search** function (Ctrl+F / Cmd+F) of your PDF reader application, type the #(hashtag) character and the wished keyword.

The **#new** special keyword indicates a new feature/function that has just appeared in the latest firmware or software version.

### Example

#dhcp

This keyword is placed at the DHCP (dynamic IP address) setting in the front panel operation, the Lightware Device Controller (LDC) and the LW3 programmer's reference section.

The following list contains all hashtag keywords placed in the document with a short description belonging to them. The list is in **alphabetical order** by the hashtag keywords.

Hashtag Keyword ↓↑	Description
#advancedview	Advanced view / Terminal window
#analogaudio	Analog audio related settings
#autoselect	Autoselect feature settings
#autotakemode	Autotake mode
#backup	Configuration cloning (backup)
#balance	Balance (for analog audio) setting
#bootload	Bootload mode setting
#buttonlock	Front panel button lock setting
#cec	CEC related settings
#commandinjection	RS-232 command injection settings
#configurationcloning	Configuration cloning (backup)
#crosspoint	Crosspoint switch setting
#devicelabel	Device label
#dhcp	Dynamic IP address (DHCP) setting
#diagnostic	Failure diagnostic related tool/information
#edid	EDID related settings
#eventmanager	Event manager
#factory	Factory default settings
#firmwareversion	Firmware version query
#framedetector	Frame detector in LDC

Hashtag Keyword ↓↑	Description
#gpio	GPIO related settings
#hdcp	HDCP-encryption related setting
#infra	Infrared port related settings
#infrared	Infrared port related settings
#ipaddress	IP address related settings
#lock	Port lock setting
#message	Message sending via communication ports
#mute	Port mute setting
#network	Network (IP address) related settings
#nosyncscreen	Test pattern (no sync screen) settings
#portstatus	Source/destination port status query
#producttype	Product type query
#protocol	RS-232 protocol setting
#reboot	Restarting the device
#restart	Restarting the device
#rs232	RS-232 related settings
#rs-232	RS-232 related settings
#serial	RS-232 related settings
#serialnumber	Serial number query
#signaltype	HDMI/DVI signal type setting
#switch	Crosspoint switch setting
#systemlog	System log
#terminal	Advanced view / Terminal window
#testpattern	Test pattern (no sync screen) settings
#unlock	Port unlock setting
#unmute	Port unmute setting
#usb	USB related settings
#volume	Volume (for analog audio) setting

## 12.10. Firmware Release Notes

The list below shows the released firmware packages with important notes.

### v1.4.4b1

Release date: 2023-10-27

#### Bugfix:

- Fixed a bug that resulted the matrices could freeze if the crosspoint state was changed by the front panel rotary knob.

### v1.4.3b1

Release date: 2022-12-09

#### Bugfix:

- Fixing the stuck of the crosspoint connection.
- Fixing the audio related issues.

### v1.4.2b3

Release date: 2022-10-27

#### New feature:

- Improves interoperability with spanning-tree protocol enabled switches during FW upgrade.

### v1.4.0b3

Release date: 2022-08-03

#### New feature:

- Support new products: MMX8x8-HT440 and MMX-HT080

### v1.3.4b2

Release date: 2022-02-01

#### New feature:

- Added support from firmware update from a host PC which is in another subnet as the device.

#### Bugfix:

- Configuration backup and restore convert script fixed to handle uncommon Event Actions.

### v1.3.2b11

Release date: 2021-08-06

#### New feature:

- Manufacturing support
- Improvement for decreasing the video crosspoint switching time

### v1.3.1b4

Release date: 2021-06-08

#### New feature:

- Update Control USB interface driver

#### Bugfix:

- Fixed GPIO handling bug (only for MMX8x8-HDMI-4K-A-USB20)

### v1.3.0b9

Release date: 2020-11-17

#### New feature:

- Added AND operator for Event Manager Conditions (Advanced Control pack v3)
- Added Condition triggering for Event Manager (Advanced Control pack v3)
- Added Variable handling for Event Manager (Advanced Control pack v3)
- Added Permanent TCP clients with configurable target IP address, and Message recognizer for TCP clients (Advanced Control pack v3)
- Added LW3 command-salvo over Http POST (protocol.lw3) (Advanced Control pack v3)
- Added Http message sending with sendHttpPost and sendHttpPut (target server IP, target filepath, header, body) (Advanced Control pack v3)
- Added method to send Wake On LAN packet (Advanced Control pack v3)
- Added cleartext login function (disabled by default) (Advanced Control pack v3)
- Added MAC filtering (Advanced Control pack v3)
- Added IP port and services filtering (Advanced Control pack v3)
- Added Macro capability (running partial device preset with tags) (Advanced Control pack v3)
- Added new method for CEC control button sendClick (Advanced Control pack v3)
- Added LMDMP (Lightware Multicast Device Management Protocol) feature.
- Added new ConnectedSource property for media output nodes.
- Modified DeviceLabel property default text to LW\_<productname>\_<serialnum>
- Added properties in root node: FirmwareVersion, PackageVersion, MacAddress.
- Added property to indicate FeaturePackVersion (Advanced Control pack v3)
- Added Condition detect on property change to anything in Event Manager (Advanced Control pack v3)
- Added Network HostName property (default: lightware-<serialnum>).

#### Bugfix:

- Improved network compatibility with 10.x.x.x IP address range.
- Minor performance improvements and modifications.
- Fixed issue with tick counter when the device is continuously operating for a very long time.
- Fixed event condition detection for floating point number properties like volume percent.
- Fixed: SwitchToNextSource function



**v1.2.2b5**

Release date: 2020-06-11

**New feature:**

- Support new product: MMX8x8-HDMI-4K-A-USB20

**v1.1.3b1**

Release date: 2020-03-17

**Bugfix:**

- New package fixes the false error message during FW upgrade.

**v1.1.2b7**

Release date: 2020-02-18

**Bugfix:**

- Manufacturing support.

**v1.1.1b13**

Release date: 2019-04-05

**New feature:**

- Added 'Forced button lock' function to lock buttons via protocol command
- RS232 Minimal Recognizer for Cisco compatibility (Cisco Login) CEC - sendCEC command (e.g. turn on the TV with Event Actions) Sending IR codes (SendProntoHex e.g. send max. 200 Byte IR code with Event Actions)

**Bugfix:**

- Fixed a bug in factory EDID F118 and F119.
- Signal parameters for disconnected output problem fixed.
- RS232 minor bugfix

**v1.1.0b10**

Release date: 2018-08-30

**New feature:**

- Added support for RS-232 minimal recogniser.
- Added feedback (on the LCD screen) to the user about the actual state of the firmware upgrade process.
- Added mic addon preset and scene.
- Added pre-defined mic EQ.
- Added CEC functionality.
- Added IR prontohex sending function.

**Bugfix:**

- Device preset HTTP post fixed.

**v1.0.0b20**

Release date: 2018-04-09

**New feature:**

- Modified DP input driver to fix HDCP issue with MacBooks
- Modified RS-232 modes to support SendMessage in Control mode
- Firmware platform library updated
- Added 'User replaceable miniweb slot' to support built-in control webpage

**12.11. Applied Ports (Network Settings)**

The following ports are necessary to pass via a network switch/firewall for proper working between the device and the softwares:

Purpose/function	Affected software	Protocol	Port nr.
Firmware update TFTP	LDU2	UDP	69
		UDP	49990
		UDP	49995
Device Discovery	LDC	UDP	224.0.0.251:5353
Remote IP	LDC	UDP	230.76.87.82:37421
Find me (LMDMP)	-	UDP	230.76.87.82:37422
LW2 protocol	-	TCP	10001
LW3 protocol	-	TCP	6107
HTTP port	-	TCP	80
RS-232 command injection	-	TCP	8001
IR command injection	-	TCP	9001, 9002

## 12.12. Factory EDID List

Mem.	Resolution			Scan type	EDID type
F1	640 x 480	@ 60.00	Hz	p	D
F2	848 x 480	@ 60.00	Hz	p	D
F3	800 x 600	@ 60.32	Hz	p	D
F4	1024 x 768	@ 60.00	Hz	p	D
F5	1280 x 768	@ 50.00	Hz	p	D
F6	1280 x 768	@ 59.94	Hz	p	D
F7	1280 x 768	@ 75.00	Hz	p	D
F8	1360 x 768	@ 60.02	Hz	p	D
F9	1280 x 1024	@ 50.00	Hz	p	D
F10	1280 x 1024	@ 60.02	Hz	p	D
F11	1280 x 1024	@ 75.02	Hz	p	D
F12	1400 x 1050	@ 50.00	Hz	p	D
F13	1400 x 1050	@ 60.00	Hz	p	D
F14	1400 x 1050	@ 75.00	Hz	p	D
F15	1680 x 1050	@ 60.00	Hz	p	D
F16	1920 x 1080	@ 50.00	Hz	p	D
F17	1920 x 1080	@ 60.00	Hz	p	D
F18	2048 x 1080	@ 50.00	Hz	p	D
F19	2048 x 1080	@ 60.00	Hz	p	D
F20	1600 x 1200	@ 50.00	Hz	p	D
F21	1600 x 1200	@ 60.00	Hz	p	D
F22	1920 x 1200	@ 50.00	Hz	p	D
F23	1920 x 1200	@ 59.56	Hz	p	D
F24	2048 x 1200	@ 59.96	Hz	p	D
F29	<b>1920 x 1080</b>	<b>@ 60.00</b>	<b>Hz</b>	<b>p</b>	<b>U</b>
F30	1440 x 480	@ 60.05	Hz	i	H
F31	1440 x 576	@ 50.08	Hz	i	H
F32	640 x 480	@ 59.95	Hz	p	H
F33	720 x 480	@ 59.94	Hz	p	H
F34	720 x 576	@ 50.00	Hz	p	H

Mem.	Resolution			Scan type	EDID type
F35	1280 x 720	@ 50.00	Hz	p	H
F36	1280 x 720	@ 60.00	Hz	p	H
F37	1920 x 1080	@ 50.04	Hz	i	H
F38	1920 x 1080	@ 50.00	Hz	i	H
F39	1920 x 1080	@ 60.05	Hz	i	H
F40	1920 x 1080	@ 60.05	Hz	i	H
F41	1920 x 1080	@ 24.00	Hz	p	H
F42	1920 x 1080	@ 25.00	Hz	p	H
F43	1920 x 1080	@ 30.00	Hz	p	H
F44	1920 x 1080	@ 50.00	Hz	p	H
F45	1920 x 1080	@ 59.94	Hz	p	H
F46	1920 x 1080	@ 60.00	Hz	p	H
F47	<b>1920 x 1080</b>	<b>@ 60.00</b>	<b>Hz</b>	<b>p</b>	<b>U</b>
F48	<b>1920 x 1080</b>	<b>@ 60.00</b>	<b>Hz</b>	<b>p</b>	<b>U</b>
F49	<b>1920 x 1080</b>	<b>@ 60.00</b>	<b>Hz</b>	<b>p</b>	<b>U</b>
F90	1920 x 2160	@ 59.99	Hz	p	D
F91	1024 x 2400	@ 60.01	Hz	p	D
F94	2048 x 1536	@ 60.00	Hz	p	D
F96	2560 x 1600	@ 59.86	Hz	p	D
F97	3840 x 2400	@ 24.00	Hz	p	D
F98	1280 x 720	@ 60.00	Hz	p	H
F99	1920 x 1080	@ 60.00	Hz	p	H
F100	1024 x 768	@ 60.00	Hz	p	H
F101	1280 x 1024	@ 50.00	Hz	p	H
F102	1280 x 1024	@ 60.02	Hz	p	H
F103	1280 x 1024	@ 75.02	Hz	p	H
F104	1600 x 1200	@ 50.00	Hz	p	H
F105	1600 x 1200	@ 60.00	Hz	p	H
F106	1920 x 1200	@ 59.56	Hz	p	H
F107	2560 x 1440	@ 59.95	Hz	p	H
F108	2560 x 1600	@ 59.86	Hz	p	H

Mem.	Resolution			Scan type	EDID type
F109	3840 x 2400	@ 24.00	Hz	p	H
F110	3840 x 2160	@ 24.00	Hz	p	H
F111	3840 x 2160	@ 25.00	Hz	p	H
F112	3840 x 2160	@ 30.00	Hz	p	H
F118	<b>3840 x 2160</b>	<b>@ 30.00</b>	<b>Hz</b>	<b>p</b>	<b>U</b>
F119	<b>3840 x 2160</b>	<b>@ 30.00</b>	<b>Hz</b>	<b>p</b>	<b>U</b>
F133	4096 x 2160	@ 60.00	Hz	p	4

### Legend

D: DVI EDID

H: HDMI EDID

U: Universal EDID, supporting many standard resolutions:

- **F29:** Universal EDID for DVI signals (no audio support).
- **F47:** HDMI EDID supporting PCM audio.
- **F48:** HDMI EDID supporting all type of audio.
- **F49:** HDMI EDID supporting all type of audio and deep color.
- **F89:** Universal EDID for analog signals (no audio support).
- **F118:** HDMI EDID supporting PCM audio and 4K@30 Hz signals.
- **F119:** HDMI EDID supporting all type of audio and 4K@30 Hz signals.

Please note that minor changes in the factory EDID list may be applied in further firmware versions.

### 12.13. Cable Wiring Guide

Inputs and outputs of audio devices are symmetric or asymmetric. The main advantage of the symmetric lines is the better protection against the noise, therefore they are widely used in the professional audio industry. Symmetric audio is most often referred to as balanced audio, as opposed to asymmetric, which is referred to as unbalanced audio. Lightware products are usually built with 5-pole Phoenix connectors, so we would like to help users assemble their own audio cables. See the most common cases below.

- ATTENTION!** Symmetric and asymmetric lines can be linked with passive accessories (e.g. special cables), but in this case half of the line level is lost.
- ATTENTION!** There are numerous types of regularly used connector and cable types to connect audio devices. Please always make sure that a connector or cable fits your system before use.
- ATTENTION!** Never join the phase-inverted (negative, cold or -) poles (either right or left) to the ground or to each other on the output side, as this can damage the unit.
- INFO:** Use a galvanic isolation in case of a ground loop.

#### The Pinout of the 5-pole Phoenix Connector



Pin nr.	Signal
1	Left+
2	Left-
3	Ground
4	Right-
5	Right+

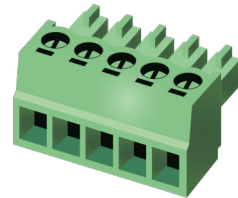

#### Compatible Plug Type

Phoenix® Combicon series (3.5mm pitch, 5-pole), type: MC 1.5/5-ST-3.5.

#### From Unbalanced Output to Balanced Input

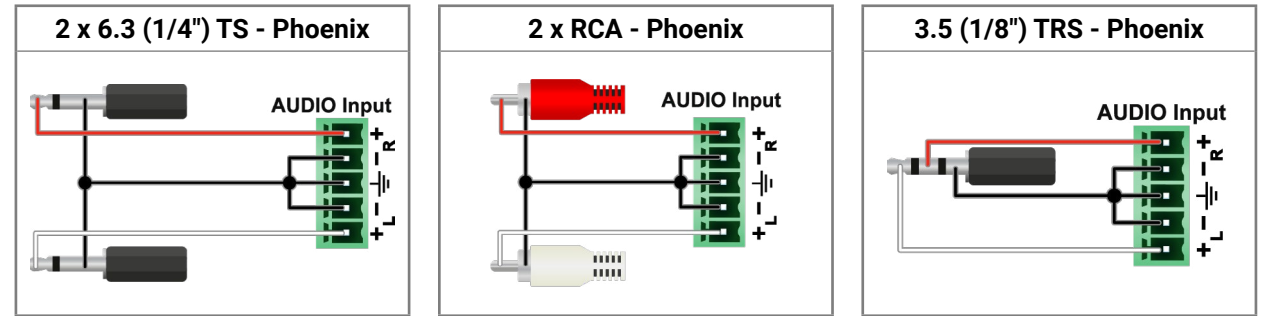

#### From Balanced Output to Unbalanced Input

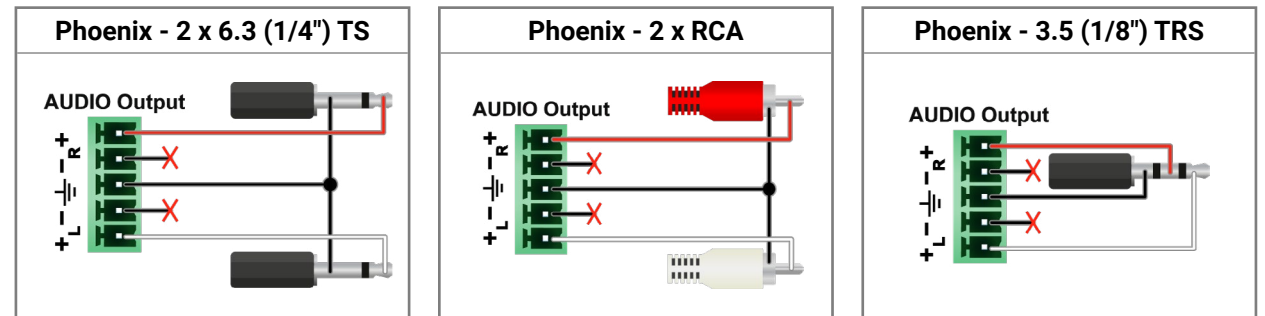

#### From Balanced Output to Balanced Input

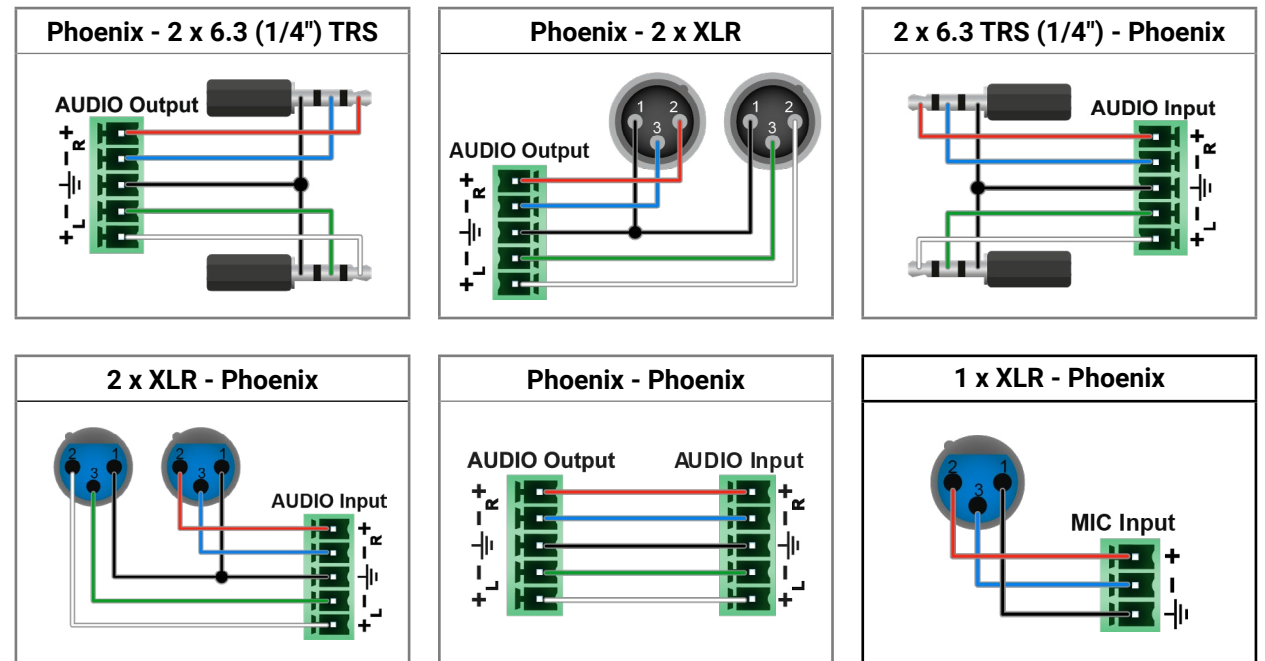

## 12.14. Further Information

### Limited Warranty Statement

1. Lightware Visual Engineering PLC (Lightware) warrants to all trade and end user customers that any Lightware product purchased will be free from manufacturing defects in both material and workmanship for three (3) years from purchase unless stated otherwise below. The warranty period will begin on the latest possible date where proof of purchase/delivery can be provided by the customer. In the event that no proof can be provided (empty 'Date of purchase' field or a copy of invoice), the warranty period will begin from the point of delivery from Lightware.

1.1. 25G and MODEX product series will be subject to a seven (7) year warranty period under the same terms as outlined in this document.

1.2. If during the first three (3) months of purchase, the customer is unhappy with any aspect of a Lightware product, Lightware will accept a return for full credit.

1.3. Any product that fails in the first six (6) months of the warranty period will automatically be eligible for replacement and advanced replacement where available. Any replacements provided will be warranted for the remainder of the original unit's warranty period.

1.4. Product failures from six (6) months to the end of the warranty period will either be repaired or replaced at the discretion of Lightware. If Lightware chooses to replace the product, then the replacement will be warranted for the remainder of the original unit's warranty period.

2. The above-stated warranty and procedures will not apply to any product that has been:

2.1. Modified, repaired or altered by anyone other than a certified Lightware engineer unless expressly agreed beforehand.

2.2. Used in any application other than that for which it was intended.

2.3. Subjected to any mechanical or electrical abuse or accidental damage.

2.4. Any costs incurred for repair/replacement of goods that fall into the above categories (2.1., 2.2., 2.3.) will be borne by the customer at a pre-agreed figure.

3. All products to be returned to Lightware require a return material authorization number (RMA) prior to shipment, and this number must be clearly marked on the box. If an RMA number is not obtained or is not clearly marked on the box, Lightware will refuse the shipment.

3.1. The customer will be responsible for in-bound and Lightware will be responsible for out-bound shipping costs.

3.2. Newly repaired or replaced products will be warranted to the end of the originally purchased product's warranty period.

### Document Revision History

Rev.	Release date	Changes	Editor
1.0	12.07.2022	Initial version (Has been separated from the original document - MMX8x4-HT series); box contents information updated - CATx cross link cable and infrared emitter/detector accessories no longer supplied	Nikolett Keindl
...			
1.3	12-05-2023	IR Message Sending examples updated	Nikolett Keindl
1.4	14-12-2022	Specifications updated	Tamas Forgacs

### Contact Us

[sales@lightware.com](mailto:sales@lightware.com)

+36 1 255 3800

[support@lightware.com](mailto:support@lightware.com)

+36 1 255 3810

**Lightware Visual Engineering PLC.**

Peterdy 15, Budapest H-1071, Hungary

[www.lightware.com](http://www.lightware.com)

©2023 Lightware Visual Engineering. All rights reserved. All trademarks mentioned are the property of their respective owners. Specifications subject to change without notice.